

**PROTECT
YOUR TRANSMISSION
SYSTEM**

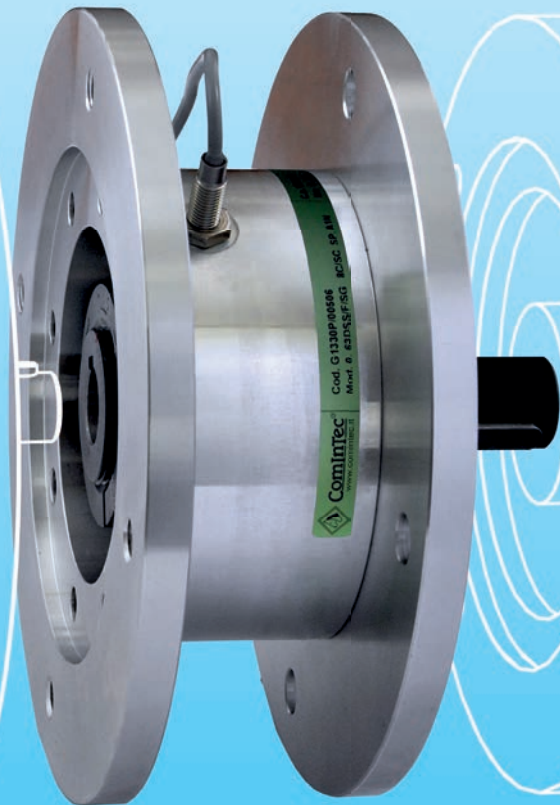

ComIntec[®]
Technology for Safety



- Overload protection
- Easy assembly and setting
- Maintenance free
- IP67 level of water ingress protection
- High corrosion resistance
- ATEX version on request
- Precision setting
- Special treatment for food/pharma applications

TORQUE LIMITERS FOR GEARBOXES

Up to 1200 Nm

.../PR-V

DSS/F/SG/PR-V - backlash free ball model for gearboxes (input shaft):

- Balls solution, torsional backlash free, maintenance free
- Instant disengagement between the driver and the driven component when the calibration torque is exceeded
- Available with 360° individual re-engagement
- Solution complete with zinc-plated STEEL connection flange for IEC and NEMA motors
- IP67 level of protection from external agents
- Integrated inductive sensor for monitoring overloads
- Maximum torque 720 Nm; maximum bore/shaft $\varnothing 48$ mm
- Available pre-calibrated and ready for use
- Anticorrosive surface treatment option for specific requirements

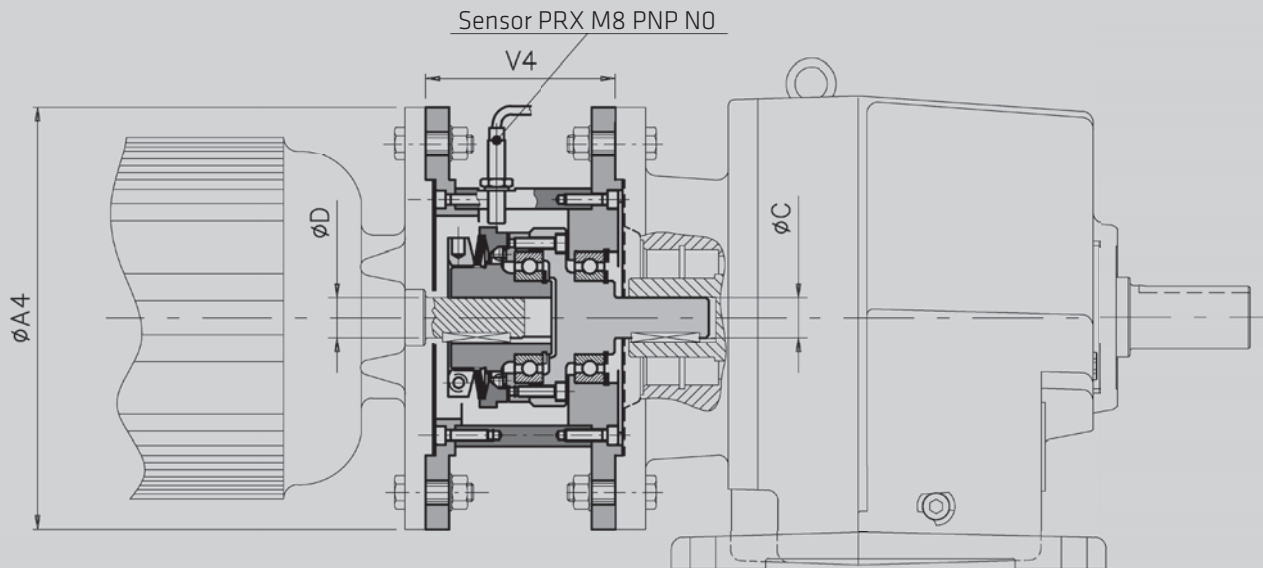

Size DSS/F/SG/PR-V	Torque [Nm]	IEC Motor Flange B5					Δ NEMA Motor Flange C					Speed Max [Rpm]
		Motor	DH7/Ch7	A4	V4	Weight [kg]	Motor	DH7/Ch7	A4	V4	Weight [kg]	
00.47	3-23	63a	11	140	52.5	3.5						4000
		71a	14	160	54.5	4.2						
0.63	5-50	80a	19	200	78	8	56C	5/8"	6.7"	3.07"	7	4000
							143TC	7/8"	6.7"	3.07"	7	
1.80	9-100	90s	24	200	90	9						3000
2.96	20-200	100La	28	250	110	17	184TC	1-1/8"	8.9"	4.41"	17	2500
		112M										
3.116	35-415	Δ 132M	38	300	110	24	215TC	1-3/8"	8.9"	4.65"	19	2000
							256TC	1-5/8"	8.9"	5.28"	20	
4.138	75-720	Δ 160L	42	350	126	33.5						1850
		Δ 180L	48			36						

Δ On request

PRX - inductive proximity sensor



- INOX IP67 stainless steel housing
- Electrical contact: 7 \pm 30 VCC and 4KHz work frequency
- Operating temperature from -20°C to +70°C.
- Output type: NPN (N.O. - N.C.); PNP (N.O. - N.C.)
- Length of cable: 2 metres (3x0.2)

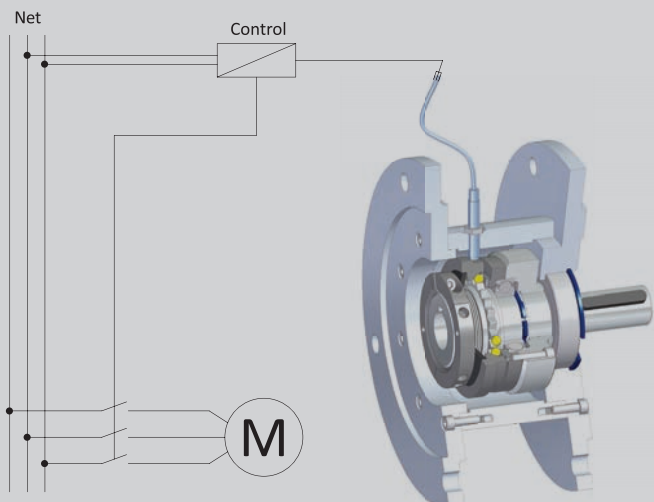

COMINTEC PR-V GEARBOX TORQUE LIMITERS PROTECT YOUR MOST EXPENSIVE SYSTEM COMPONENTS FROM TORQUE OVERLOADS. MOUNTED BETWEEN THE MOTOR AND THE GEARBOX INSTANTLY DISENGAGES COMPONENTS BEFORE DAMAGE OCCURS

Applications

- Food & Beverage Equipment
- Wastewater Treatment
- Packaging Equipment
- Shredders/Recycling

How it works

- Mounts directly to the motor and gearbox
- Suited for flange motors and gearbox
- No design work required
- Instant disengagement

Construction

- Ball detent style
- Housing: Standard Zinc plated steel
- Torque Limiter: Machined Steel
- Sensor: inductive proximity integrated

Technical

- Units are preset to requested torque setting
- Torque setting is adjustable and easy to change
- Automatic reset after 360° rotation
- IP67 rated

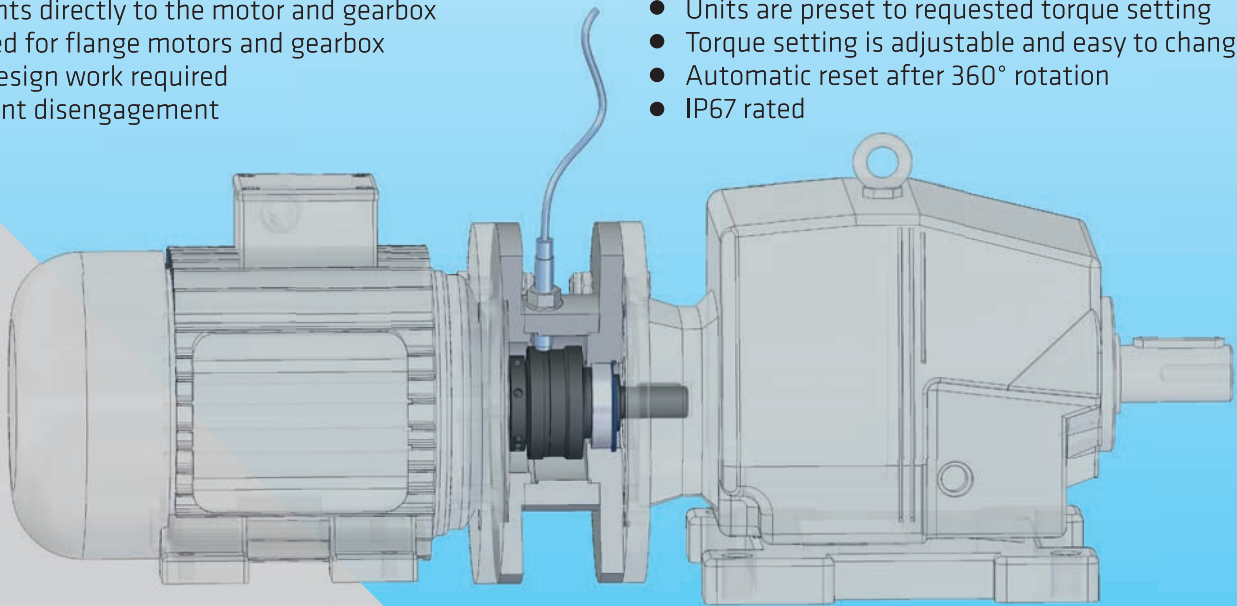

	ComInTec PR-V model	High Torque Ball Detent	Friction Style	Electric Sensing
Disengagement	+ Instant	+ Instant	- Friction	- Delayed
Installation	+ Simple interface with motor and gearbox	+ Output of Gearbox	+ Simple interface	- Integrated into electronic circuits
Dimension	+ Compact design	- Larger size due to high torque	+ Compact design	+ Small physical size
Maintenance	+ None required	+ None required	- Replace worn components	- Frequent checking of calibration
Price	€€€	€€€€€	€€	€

+ technical value

- technical value



COMINTEC PR-V MODEL OFFERS EASE OF DESIGN, INSTALLATION AND THE SAME PROTECTION OF THE HIGH TORQUE BALL DETENT DEVICES AT A BETTER PRICE POINT.

DF/TAC/PR-V - Friction model for gearboxes (input shaft):

- Friction solution, compact and economical
- The drive component slips when the calibration torque is exceeded without fully disengaging the drive transmission
- Asbestos free friction rings
- Available with friction rings with performance specifications designed to suit the application
- Solution including aluminium connection flanges for IEC motors
- Integrated inductive sensor option for monitoring overloads
- Maximum torque 1200 Nm; maximum bore/shaft $\varnothing 55$ mm
- Available pre-calibrated and ready for use
- Anticorrosion surface treatment option for specific requirements

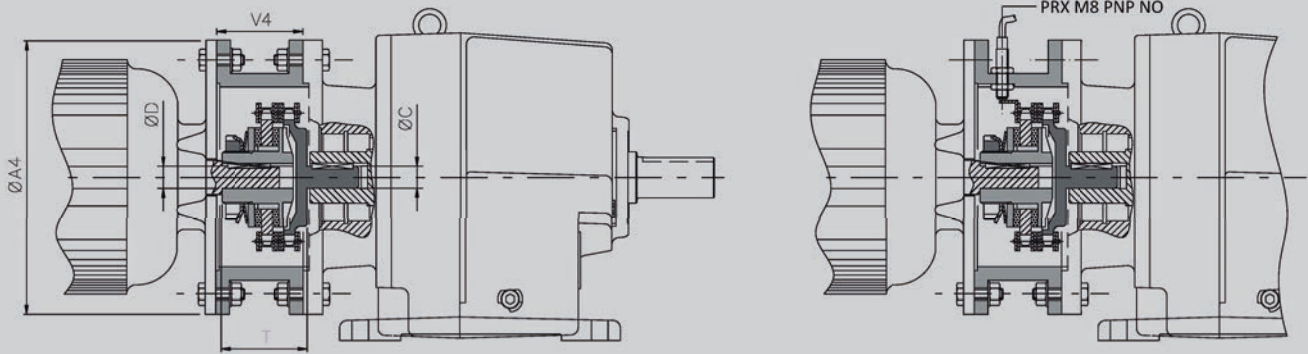

Size DF/TAC/PR-V	Torque [Nm]	IEC Motor Flange B5					Max Speed [Rpm]
		Motor	DH7/Ch7	A4	V4	Weight [kg]	
00.38	1-34	63a	11	140	43	1.1	5000
		71a	14	160	43	1.2	
0.50	2-100	80a	19	200	45.5	2	3800
		90s	24	200	45.5	2.7	
1.70	6-210	90s	24	250	66	4.8	2800
2.90	13-450	100La	28	300	83.5	9	2200
		112M					
3.115	65-950	Δ 160L	42	350	121	16	1800
		Δ 180L	48		16.2		
4.140	180-1200	Δ 200L	55	400	122	27	1500

Δ On request

Model **DF/TAC/PR-V** complete with spacer to be assembled between the motor and gearbox with **PRX** inspection and sensor.

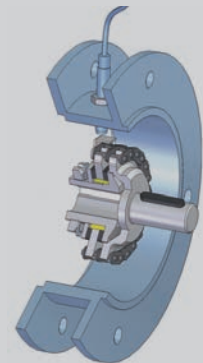

ComInTec S.r.l.

Via Dell'artigiano, 9
40055 Villanova di Castenaso (BO) - Italy
Tel. +39 051 780216 - Fax +39 051 782256
info@comintec.it - www.comintec.com

MADE IN ITALY

