

NTN-SNR SOLUTIONS SEALED BEARING KITS FOR CONVEYORS

QUARRIES, MINES & CEMENT PLANTS



www.ntn-snr.com



With You



SPECIFIC CHARACTERISTICS:

- Longer service life of the bearing
- Reduced maintenance costs
- Reduction of environmental impact
- Interchangeability with standard open bearings



**CREATED TO INCREASE
PRODUCTIVITY,
PERFORMANCE AND
RELIABILITY IN HARSH
ENVIRONMENTS**

OPT FOR THE ALL-IN-ONE

Benefits of kits

- No error in the choice of components
- Simplicity of ordering and storage
(Only 1 reference to manage instead of 3)
- No oversight at the time of mounting
- Mounting kit for fixed and floating bearings (2 in 1)*

* Mounting in standard cast iron bearing housing (SNC NTN-SNR type)

SEALED BEARING KITS FOR CONVEYORS



Shaft diameters

from 35 to 90 mm

26 available KIT references:

13 with normal clearance

13 with C3 clearance

On request, possibility of extending the range to other shaft diameters

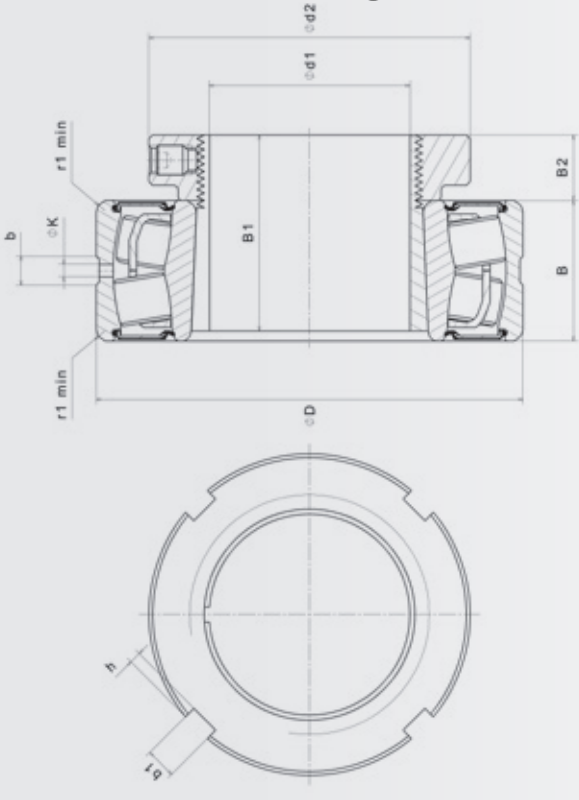

Description	Overall dimensions		Fatigue load limit		Basic capacity		Calculation factors				Limit speed rpm	Weight kg	Number of holes	Dimensions							Fitting dimensions		
	d ₁	D	B	C _u	C	C ₀	e	Y ₁	Y ₂	Y ₃				b	K	r ₁	d ₂	B ₁	B ₂	b ₁	h	D _a max.	r _a max.
	mm		kN		kN		mm							mm									
KIT10X22208EAKW33EE	35	80	28	11,2	116	105	0,27	2,47	3,67	2,41	2300	1	3	5,4	2,5	1,1	58	46	13	6	2,5	73,9	1
KIT10X22209EAKW33EE	40	85	28	12,7	121	113	0,26	2,64	3,93	2,68	2100	1	3	5,8	2,5	1,1	65	39	13	6	2,5	78,7	1
KIT10X22210EAKW33EE	45	90	28	14,5	130	124	0,24	2,84	4,23	2,78	2000	1,1	3	5,8	2,5	1,1	70	42	14	6	2,5	83	1
KIT10X22211EAKW33EE	50	100	31	18	155	148	0,23	2,95	4,4	2,89	1800	1,4	3	6,4	3	1,5	75	45	14	7	3	93,9	1,5
KIT10X22212EAKW33EE	55	110	34	22,1	187	181	0,24	2,84	4,23	2,78	1600	1,8	3	6,9	3	1,5	80	47	14	7	3	102,5	1,5
KIT10X22213EAKW33EE	60	120	38	25,2	226	224	0,24	2,79	4,15	2,73	1500	2,5	3	7,8	3,5	1,5	85	65	15	7	3	116,4	1,5
KIT10X22214EAKW33EE	60	125	38	28,8	235	240	0,22	3,01	4,48	2,94	1400	2,6	3	7,4	3,5	1,5	92	52	15	8	3,5	117,1	1,5
KIT10X22215EAKW33EE	65	130	38	30,3	224	249	0,22	3,14	4,67	3,07	1300	2,9	3	7,4	3,5	1,5	98	55	16	8	3,5	121,6	1,5
KIT10X22216EAKW33EE	70	140	40	34,5	278	287	0,22	3,14	4,67	3,07	1200	3,5	3	7,9	3,5	2	105	59	18	8	3,5	131,5	2
KIT10X22217EAKW33EE	75	150	44	38,8	324	330	0,22	3,07	4,57	3	1200	4,2	3	7,9	3,5	2	110	63	19	8	3,5	140,8	2
KIT10X22218EAKW33EE	80	160	48	43,3	384	398	0,23	2,9	4,31	2,83	1000	5,3	3	10	4,5	2	120	73	19	10	4	149	2
KIT10X22219EAKW33EE	85	170	51	47,9	416	417	0,23	2,95	4,4	2,89	1100	6,3	3	9,9	4,5	2,1	125	90	20	10	4	158	2
KIT10X22220EAKW33EE	90	180	55	53	472	495	0,24	2,84	4,23	2,78	1000	7,5	3	11	5	2,1	130	97	21	10	4	168	2

This document is the exclusive property of NTN-SNR ROULEMENTS. Any total or partial reproduction hereof without the prior consent of NTN-SNR ROULEMENTS is strictly prohibited. Legal action may be brought against anyone breaching the terms of this paragraph. NTN-SNR ROULEMENTS shall not be held liable for any errors or omissions that may have crept into this document despite the care taken in drafting it. Due to our policy of continuous research and development, we reserve the right to make changes without notice to all or part of the products and specifications mentioned in this document.

Distribué par :



With You

NTN-SNR ROULEMENTS - 1 rue des Usines - 74000 Annecy
FCS ANNECY B 325 821 072 - Code APE 2815Z - Code NACE 28.15

www.ntn-snr.com