

6	COMPANY PROFILE
18	TRAPEZOIDAL SCREW JACKS
20	Production line
26	Specifications
27	Glossary
28	Static loads
30	Backlash and handling
32	Lubrication
34	Installation and maintenance
36	Exploded views and spare parts
38	Dimensioning
46	Power tables
60	Dimensional tables
67	Accessories
89	Norms
90	Mounting schemes
92	ALEPH SCREW JACKS
94	Specifications
95	Glossary
96	Handlings
97	Installation and maintenance
98	Exploded views and spare parts
100	Dimensioning
107	Power tables
110	Dimensional tables
112	Accessories
119	Norms
120	BALL SCREW JACKS
122	Production line
126	Specifications
127	Glossary
128	Backlash and handling
129	Lubrication
130	Installation and maintenance
132	Exploded views and spare parts
134	Dimensioning
140	Power tables
142	Dimensional tables
149	Accessories
161	Norms
162	Mounting schemes



Ease of use and high reliability make UNIMEC trapezoidal screw jacks suitable for a wide variety of uses. They can be employed to lift, pull, move, or align any kind of loads, with a perfect synchronism which can hardly be obtained with other handling methods.

UNIMEC trapezoidal screw jacks are absolutely irreversible, that is, they can support their applied loads without needing any brakes or other locking systems.

The screw jacks can be employed singularly or in groups properly connected with shafts, joints, and/or bevel gearboxes.

They can be driven by different motors: electrical, with either alternating or direct current, as well as hydraulic or pneumatic motors. Also they can be driven manually or with any other type of transmission.

In addition to the models shown on the following pages, UNIMEC can produce custom designed screw jacks to meet all the requirements. UNIMEC trapezoidal screw jacks are designed and manufactured using innovative technology so to supply a product which identifies itself with the state of the art in the transmission devices.

trapezoidal screw jacks



The highest quality and a 28 years long experience are able to meet the most demanding and sophisticated requirements.

The outer surfaces are completely machine finished and the parts are assembled with special care, in order to allow the application of supports, flanges, pins, or any other components a project may require. The application of double guides throughout the product line provides a very good running efficiency even under the most strenuous operating conditions.

Special sealing systems enable the inner gears to operate in a bath of lubricant, which guarantees them a long lasting life.



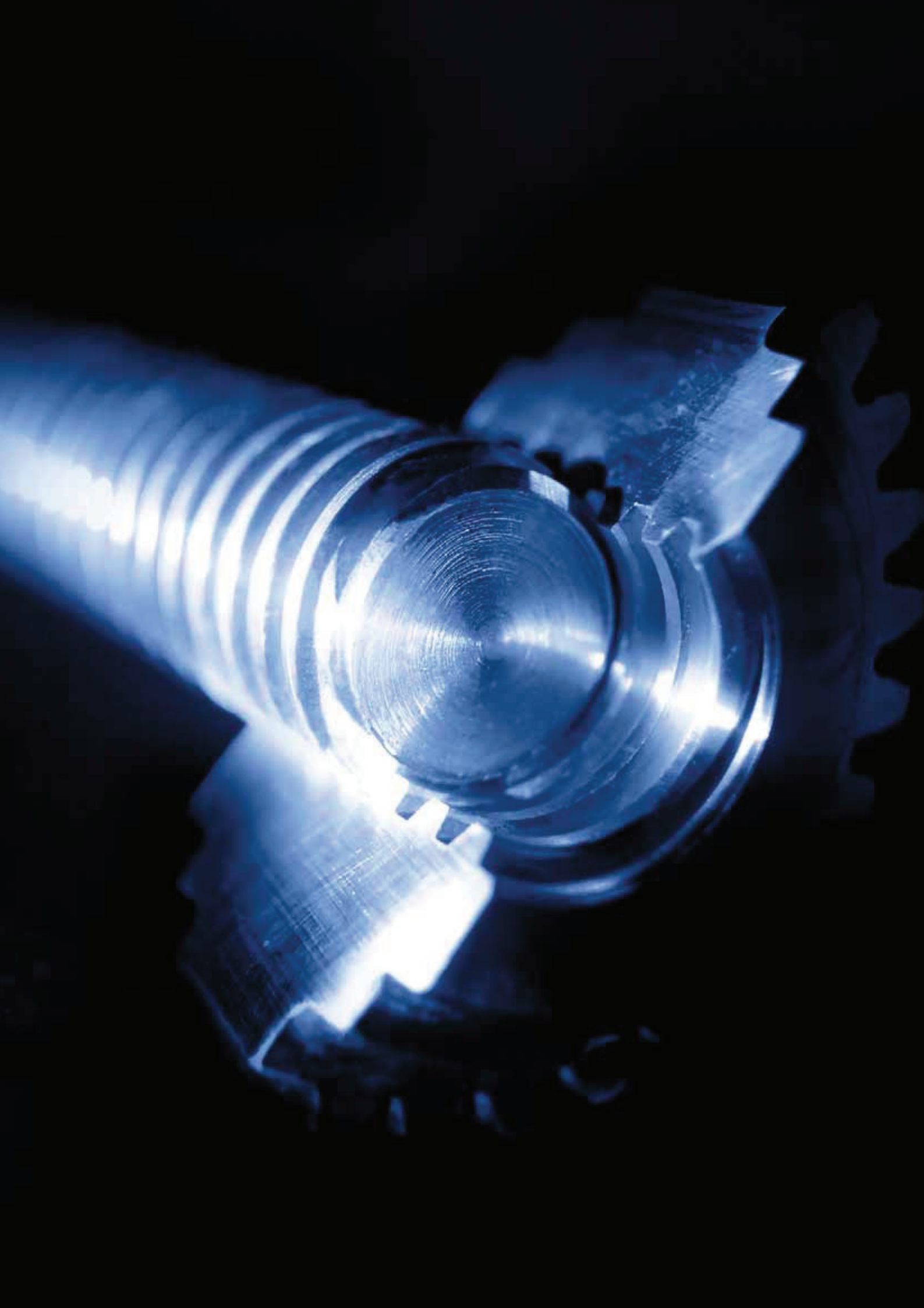



60 TP

Threaded spindle model with translating threaded spindle.
The rotation of the worm screw is transformed in the axial movement of the threaded spindle by means of the worm wheel. The threaded spindle must have a rotational constraint.



CTP

TP model screw jacks arranged for direct coupling to single phase, three-phase, self-braking, direct current, hydraulic, pneumatic motors, etc. by means of a bell house and a joint.



62 TPR

Threaded spindle model with rotating threaded spindle. The rotation of the worm screw actuates the movement of the worm wheel which causes the threaded spindle to move, being fixedly connected to it. The external support nut (lead nut), transforms the rotational movement of the threaded spindle into a linear movement. The support nut must have a rotational constraint.



CTPR

TPR model screw jacks arranged for direct coupling to single phase, three-phase, self-braking, direct current, hydraulic, pneumatic motors, etc. by means of a bell house and a joint.



67 MTP

TP model screw jacks arranged for direct coupling to single phase, three-phase, self-braking, direct current, hydraulic, pneumatic motors etc.



RTP

TP model screw jacks arranged for direct coupling to reducers or worm screw or coaxial motor reducers, etc.



67 MTPR

TPR model screw jacks arranged for direct coupling to single phase, three-phase, self-braking, direct current, hydraulic, pneumatic motors etc.



RTPR

TPR model screw jacks arranged for direct coupling to reducers or worm screw or coaxial motor reducers, etc.



VARIOUS END FITTINGS

64



BU 70

TP model screw jack with anti-withdrawing bush



PR 67

TP model screw jacks with rigid protection.



PRF 71

TP model screw jacks with rigid protection and stroke control.



PRO 68

TP model screw jacks with oil bath rigid protection.



PE 72

TP model screw jacks with elastic protection.



CU 69

TP model screw jack oil proof assembled



PE 72

TPR model screw jacks with elastic protection.



production line



74 PRA

TP model screw jacks with rigid protection and dual-guide anti-rotation.



77 CSU

TP model screw jacks with safety lead nut for automatic wear control.



75 AR

TP model screw jacks with grooved anti-rotation spindle.



77 CSU

TPR model screw jacks with safety lead nut for automatic wear control.



76 CS

TP model screw jacks with safety lead nut for monitored wear control.



78 SU

TP model screw jacks with lead nut for monitored wear control.



76 CS

TPR model screw jacks with safety lead nut for monitored wear control.



78 SU

TPR model screw jacks with lead nut for monitored wear control.



SUA
TP model screw jacks with lead nut for automatic wear control.



SUA
TPR model screw jacks with lead nut for automatic wear control.



RG
TP model screw jacks with anti axial backlash lead nut.



RG
TPR model screw jacks with anti axial backlash lead nut.



CR
TP model screw jacks with worm wheel rotation control.



CR
TPR model screw jacks with worm wheel rotation control.



CT
TP-TPR model screw jacks with casing temperature control.



CTC
TPR model screw jack with lead nut temperature control.





82 SP
TP model screw jacks with additional mounting plates.



82 SP
TPR model screw jacks with additional mounting plates.



83 FP
TP model screw jacks with pass-through holes for bolts.



83 FP
TPR model screw jacks with pass-through holes for bolts.



84 P0
TP model screw jacks with rigid rocking protection.



85 P
TP model screw jacks with lateral pins.



85 P
TPR model screw jacks with lateral pins.



86 DA
Double action TPR model screw jacks.



FD
TPR model screw jacks for fast disassembling of the trapezoidal spindle.



TP model screw jacks with special end fittings.



AM
TP model screw jacks with over-size spindle.



TP model screw jacks with telescopic spindle.



AM
TPR model screw jacks with over-size spindle.



METAL PROTECTION

TP model screw jacks with metal protection.



Models

TP model: threaded spindle with axial translation.

The input rotation of the worm screw is transformed in the axial translation of the threaded spindle by means of the worm wheel. The load is applied on the threaded spindle which must have a rotational constraint.

Trapezoidal screw jacks

TPR model: with rotational threaded spindle and external support nut (lead nut).

The input rotation of the worm screw causes the rotation of the threaded spindle which is attached to the worm wheel. The load is applied to an external support nut (lead nut) which must have a rotational constraint.

End fittings

To meet the widest possible range of needs, various types of end fittings are available, which can be custom made upon request.

Casings

Casings are made of various materials depending on the size of screw jacks. For screw jacks of the 183 series, casings are made of cast aluminium AlSi12 (according to the UNI EN 1706:1999 requirements), for the series between the sizes 204 and 9010, casings are made of grey cast iron EN-GJL-250 (according to the UNI EN 1561:1998 requirements); and for the extra heavy series, from size 10012, the casing is made of electro-welded carbon steel S235J0 (according to the UNI EN 10025-2:2005 requirements).

Worm screws

For the entire screw jacks line, worm screws are made of a special steel 16NiCr4 (according to the UNI EN 10084:2000). They undergo thermal treatments like case-hardening and carburizing before being thoroughly ground both on the threads and on the tangs.

Worm wheel and support nut

The worm wheels and support nuts (lead nuts) are made of a special high-resistance aluminium bronze CuAl10Fe2-C (according to the UNI EN 1982:2000 requirements). The trapezoidal geometry of the threading meets the requirements of the ISO 2901:1993 norm. The worm wheels toothing profile has been designed especially for our screw jacks and can easily support a heavy-duty use.

Threaded spindles

The threaded spindles are mainly manufactured by rolling carbon steel C 45 grounded bars (according to the UNI EN 10083-2:1998 requirements). Said process, which is temperature controlled, allows to include in our standard production 6 meter long bars. The trapezoidal geometry of the threading meets the requirements of the ISO 2901:1993 norm. Threaded spindles made of stainless steel AISI 316 or other materials can be manufactured upon request for length up to 12 meters.

Protections

Protections can also be applied in order to prevent dust and foreign matters from coming into contact with the coupling and causing damages to the threaded spindle and its support nut. For TP models, a steel rigid tube can be provided on the back side, while the front side can be protected by polyester and PVC elastic bellows. In TPR models only elastic protections can be applied.

Bearings and market materials

Top-quality bearings and market materials are used for the whole line.



GLOSSARY

C	=	unit load to be handled [daN]
C_e	=	equivalent unit load [daN]
C_t	=	total load to be handled [daN]
DX	=	left hand spiral threading
F_{rv}	=	radial forces on the worm screw [daN]
f_a	=	ambient factor
f_s	=	service factor
f_t	=	temperature factor
M_{tm}	=	torque on the drive shaft [daNm]
M_{tv}	=	torque on the worm screw [daNm]
N	=	number of screw jacks and bevel gearboxes under a single handling
n	=	number of screw jacks under a single handling
P	=	mounting power requirement [kW]
P_i	=	input power to the single screw jack [kW]
P_e	=	equivalent power [kW]
P_u	=	output power to the single screw jack [kW]
rpm	=	rounds per minute
SX	=	left hand spiral threading
v	=	axial translation speed of the load [mm/min]
η_m	=	screw jack running efficiency
η_c	=	configuration running efficiency
η_s	=	structure running efficiency
ω_m	=	motor angular speed [rpm]
ω_v	=	worm screw angular speed [rpm]

Unless otherwise specified all dimensional tables show linear measurements expressed in [mm].
All the reduction ratios are expressed in the form of a fraction, unless otherwise specified.

LOAD ANALYSIS AND COMPOSITION

Choosing the right screw jack, and hence also its proper functioning, mostly depends on the identification of the real load acting on the screw jack. Loads can be divided in two main groups: static loads and dynamic loads; these groups are further made-up of: traction loads, compression loads, lateral loads, radial loads, eccentric loads, loads from shocks, loads from vibrations.

STATIC LOADS

A static load is the force that will be applied to the screw jack transmission devices while they are not in motion.

DYNAMIC LOADS

A dynamic load is the force that will be applied to the screw jack transmission devices while they are in motion.

TRACTION LOADS

A traction load is the force applied to the threaded spindle axis with an opposite direction to the casing.



COMPRESSION LOADS

A compression load is a force applied to the threaded spindle axis with the same direction as the casing.



LATERAL LOADS

A lateral load is a force applied perpendicular to the threaded spindle axis.



ECCENTRIC LOADS

An eccentric load is a force whose centre of application does not belong to the threaded spindle axis, even having the same direction.



LOADS FROM SHOCKS

A load from shocks is a load where the impulse forces generated by an impact are not quantifiable.

LOADS FROM VIBRATIONS

A load from vibrations is applied when a shock load increases the impulse frequency.

Depending on the type of load some solution must be applied during the design phase:

STATIC TRACTION LOAD

The maximum applicable load for all models and sizes is shown in the specification tables. Shocks and/or lateral loads limit its applications.

DYNAMIC TRACTION LOAD

The maximum dynamic traction load which can be applied to a screw jack does not only depend on its size: it could be limited by the ambient temperature, service factors and possible lateral loads and/or shocks. It is thus necessary to check all those parameters.

STATIC COMPRESSION LOAD

The maximum load which can be applied is determined by the length of the threaded spindle as well as by the constraints it undergoes. The limit applicable load can be obtained on the basis of the Euler diagrams. Its application could be limited by possible shocks and/or lateral loads.

DYNAMIC COMPRESSION LOAD

The maximum compression load which can be applied is determined by many factors: the length of the threaded spindle, the ambient temperature, service factors and possible lateral loads and/or shocks. In addition to all the verifications already foreseen in the case of a traction load, further verifications are necessary relative to the Euler diagrams.

STATIC LATERAL LOAD

This kind of load induces a lateral shifting of the threaded spindle causing a damaging bending which limits the ability of the screw jack. Suitable graphs show the maximum lateral load values according to the length and size of the threaded spindle. For any further and more detailed verifications our technical office is at your disposal.

DYNAMIC LATERAL LOAD

A lateral load in dynamic applications is **not allowed**. In case of essential use of screw jacks with lateral load is for machine requirements, it will be necessary to contact our technical office.

ECCENTRIC STATIC LOAD

An eccentric load in static applications induces the same problems as the lateral loads. For this reason the above considerations are also applicable to this kind of load.

DYNAMIC ECCENTRIC LOAD

In case of handling an eccentric load, in order to avoid problems due to lateral load, it is necessary to create a suitably guided and sized mechanical structure, in order to absorb all the lateral components of the load. The guide must be realized very carefully: too narrow backlashes could cause seizure and stick-slips, while too rough backlashes would make useless the construction of the guide itself.

STATIC LOAD FROM VIBRATIONS OR SHOCKS

A load from vibrations or from shock, if not very heavy, could be the **only reasons for the reversibility** of the transmission moved by the screw jack. In that case it is advisable to contact our technical office in order to verify the screw jack applicability.

DYNAMIC LOAD FROM VIBRATIONS OR SHOCKS

A dynamic load from vibrations or from shock can be damaging for the screw jack: stick-slip phenomena and consequent local overloads can enormously increase the wear conditions. It is necessary to minimize the shocks entity and the vibrations width

BACKLASH

Backlash on the worm screw

The worm screw – worm wheel coupling has a small degree backlash. Due to the reduction ratio and the transformation from the rotation movement to the translation movement, this backlash becomes an error of less than 0,05 mm in the linear positioning of the threaded spindle.

Lateral backlash in TP models

The thread spindle and worm wheel coupling presents a natural and necessary lateral backlash indicated by A in the drawing below. The use of a double serial guide allows to minimize the entity of said backlashes, while keeping the spindle and support nut axes aligned. The angular backlash on the coupling is translated on the spindle end fitting into a linear measure whose value depends on the size of the screw jack and grows according to the length of the spindle itself. Traction loads tend to reduce this backlash, while compression loads induce the opposite effect.

Lateral backlash in TPR models

In TPR models the spindle and the worm wheel are locked by means of a double pins. UNIMEC carries out this operation by means of a suitable machine which keeps the axes of the two components coincident during the two drillings and the consequent pins insertions. Hence, the threaded spindle rotates minimizing the oscillations due to concentricity errors. For a proper operation it is necessary for the user to provide solutions able to keep the spindle and the lead nut aligned. The guides can be external or directly implicate the structure of the lead nut, as can be seen in the following drawings.

Drawing A: the lead nut is connected to the load by means of particular screws which allow it to fit into the threaded spindle position. The guides must be realized externally.

Drawing B: The lead nut, which has been properly milled, is connected to the load by means of brackets which ensure anti-rotation. The brackets must be realized externally.

Drawing C: The lead nut, which has been properly milled, is connected to the load by means of brackets which ensure anti-rotation. The upper additional ring acts as a guide.

Drawing D: The double ring guarantees a higher reliability with respect to the C system.

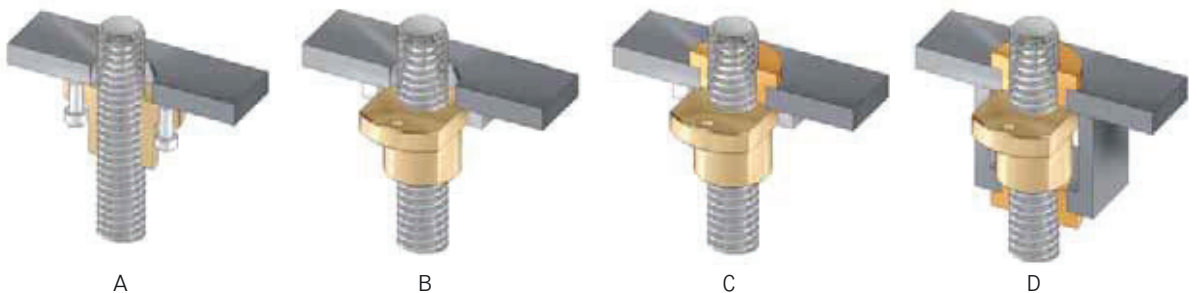

Axial backlash

In B the axial backlash between the threaded spindle and its support nut (either a worm wheel or a lead nut) is caused by the natural and necessary tolerance characterizing this kind of couplings. For construction purposes it is only important in the case where the load changes its direction of application. For applications where there can be reciprocating traction and compression loads, and therefore a need to compensate the axial backlash, it is possible to apply a backlash reduction system. The axial backlash reduction must not be forced in any case, in order to avoid that the screw and the support nut get blocked.

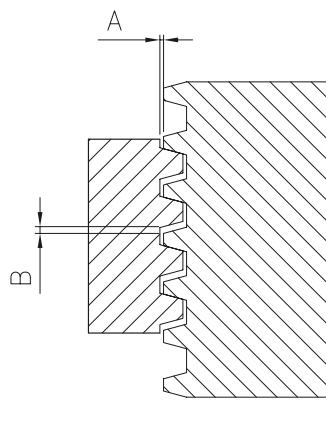

HANDLINGS

Manual operation

All screw jacks in the series can be manually operated. The following table expresses in [daN] the maximum load that can be handled according to the reduction ratio of screw jacks, considering the application of a force of 5 daN on a handwheel having a radius of 250 mm. Obviously, greater loads can be manually handled by applying further reductions to the screw jack or by increasing the radius of the handwheel.

Size	183	204	306	407	559	7010	8010
fast ratio [daN]	500	1000	2000	1500	1000	900	860
normal ratio [daN]	500	1000	2500	2900	2000	1600	1500
slow ratio [daN]	-	1000	2500	5000	4300	3200	3200

Motorized operation

Motors can be used for all jacks in the series. As a standard production, for the IEC unified motors, it is possible to connect them directly to screw jacks having a size between 204 and 8010. Special flanges can be made for hydraulic, pneumatic, brushless motors, as well as for direct current motors, permanent magnet motors, stepper motors and other special motors. In the case where it is not possible to motorize a screw jack directly, a connection by means of a bell house and a joint can be foreseen. In special cases it is also possible to motorize size 183 and the s over 8010. The power tables determine, in case of unit service factors and for every single screw jack, the moving power and the input torque according to the size, the ratio, the dynamic load and the linear speed.

Rotation directions

The rotation directions and the respective linear movements are showed in the drawings below. In standard conditions **UNIMEC supplies screw jacks equipped with right handed worm screw, to which the movements illustrated in drawings 1 and 2 correspond.** Upon request it is possible to have a left-handed worm screw, which the movements illustrated in drawings 3 and 4 correspond to. The combinations between threaded spindles and left-handed or right-handed worm screw, lead to the four combinations listed in the table below. We remind, that UNIMEC's standard production does not include motorized left-handed worm screw.

Worm screw	DX	DX	SX	SX
Threaded spindle	DX	SX	DX	SX
Direct motorization on the worm screw	Possible	Possible	Impossible	Impossible
Handling	1-2	3-4	3-4	1-2

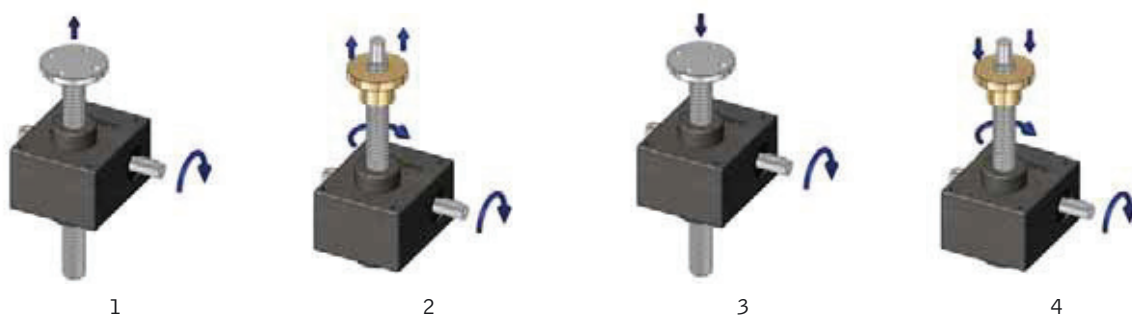

Emergency operation

In case of black-out, in order to be able to operate the single screw jacks or the complete structures by means of a crank, a free end on the screw jack worm screw or on the transmission is to be foreseen. In case of self-braking motors or worm screw motor reducers, the brake must firstly be released and then it is necessary to disassemble those components from the transmission as the reducer could also be irreversible.

It is advisable to equip the emergency operation mechanism with a safety device to cut the electric circuit.

LUBRICATION

Inner lubrication

The lubrication of the inner transmission devices to the casing is made, in the serial production, using a long lasting grease: TOTAL CERAN CA. It is an extreme pressure lubricant based on calcium sulfonate.

For size 183, on the contrary, the TOTAL MULTIS MS 2 is used, which is a calcium-soap grease, suited for extreme pressures as well. In any case a plug is foreseen for all sizes (except for 183) in case of lubricant filling up.

The technical specifications and the application field for the lubricant inside the casing are listed below.

Lubricant	Application field	Operating temperature [°C]*	Technical specifications
Total Ceran CA	standard	-15 : +130	DIN 51502: OGPON -25 ISO 6743-9: L-XBDIB 0
Total Multis MS2	standard (183)	-15 : +100	DIN 51502: MPF2K -25 ISO 6743-9: L-XBCEB 2
Total Nevastane HT/AW-1	Food industry	-10 : +150	NSF-USDA: H1

* for operating temperatures included between 80°C and 150°C Viton® seals should be used;
for temperatures higher than 150°C, and lower than -20°C, it is advisable to contact our Technical office.

The quantity of lubricant contained in the screw jacks is listed in the following table.

Size	183	204	306	407	559	7010	8010	9010	10012	12014	14014	16016	20018	25022
Inner lubricant quantity [kg]	0,06	0,1	0,3	0,6	1	1,4	1,4	2,3	4	4	14	14	28	28

The threaded spindle

The end user is responsible for the lubrication of the threaded spindle which must be carried out using an adhesive lubricant, addicted for extreme pressures:

Lubricant	Application field	Operation temperature [°C]	Technical specifications
Rothen 2000/P Special (additive which can also be used pure)	standard	0 : +200	Not foreseen
Total Carter EP 2200 (not compatible with polyglycol oils)	standard	0 : +150	AGMA 9005: D94 DIN 51517-3: CLP-US STEEL 224
Total Nevastane EP 1000	Food industry	0 : +130	NSF-USDA: H1

Lubricating the threaded spindle is an important and determining factor in the proper functioning of the screw jack. It must be carried out at regular intervals that can assure a constant coat of clean lubricant between the contact parts. Insufficient lubrication, the use of an oil without extreme pressure additives or an improper lubrication can lead to abnormal overheating and consequent wear phenomena, which naturally reduce the operating life of the screw jacks. In case the screw jacks are not visible or the threaded spindles are covered by protections, it is necessary to periodically verify the lubrication conditions. For heavier duties than those showed in the relative tables it is recommended to contact our Technical office.



Semi-automatic lubrication

Many different systems of automatic lubrication are feasible, only the most common ones are listed as follows:

- 1 - For vertically mounted TP model screw jacks, it is possible to provide an oil bath rigid protection (with recirculation option) or, in case of high performances, a single chamber operation. This kind of lubrication will be described in details on page 68-69.
- 2 - Application of a additional ring on the cover in order to create a lubricant recovery tank.
- 3 - Use of a lubricant drop-applicator to be applied to a hole made in the cover for TP models, and in the lead nut for TPR models.

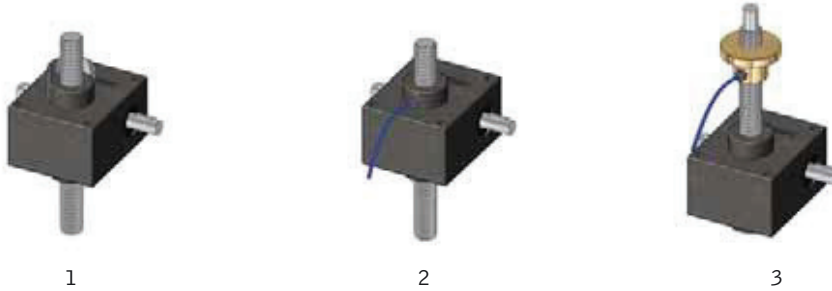

Centralized lubrication

Many automatic lubrication systems with a central pump and various distribution points are also possible. The amount of lubricant required depends on the duty and work environment. A centralized dosing system does not exclude a periodic check of the lubrication conditions in the threaded spindle.

INSTALLATION AND MAINTENANCE

Installation

The screw jack must be installed in a manner that does not create lateral loads on the threaded spindle. Great care must be taken to ensure that the threaded spindle is orthogonal to the mounting plane, and that the load and threaded spindle are on the same axis. Employing multiple screw jacks to handle the same load (see the mounting schemes section on pages 90-91) requires further verifications: it is critical that the load support points, (the end fittings for TP models and the lead nuts for TPR models), are perfectly aligned in order that the load can be uniformly distributed; otherwise the misaligned screw jacks would act as brake or counter-load. Whenever several jacks have to be connected by means of transmission shafts, it is recommended that they be perfectly aligned in order to avoid overloading of the worm screws. It is advisable to use joints capable of absorbing alignment errors but having, at the same time, a rigid torsion necessary to keep the synchronization of the transmission. The assembly or disassembly of the joints or pulleys of worm screw must be carried out by means of tie rods or extractors, using, if necessary, the threaded hole on top of the worm screw; striking or hammering could damage the inner bearings.

For heat-shrinking joints or pulleys, we recommend a temperature between 80-100 °C. Installations environments with dust, water, vapors, etc. require precautions to protect the threaded spindle. This can be done by using elastic or rigid protections.

The above protections are also used in order to avoid any accidental human contact with the moving devices. For civil applications it is always advisable to use the safety components.

Preparing for service

All UNIMEC's screw jacks are supplied filled with long lasting lubricant which ensures a perfect lubrication of the worm gear/worm wheel group and all the inner parts. All screw jacks (except for the size 183) are equipped with a lubricant plug for filling-up the lubricant as necessary.

As clearly explained on relative paragraph, lubrication of the threaded spindle is a user's responsibility and must be carried out periodically depending on the duty conditions and the operating environment. Special systems are available for holding the screw jacks in any position without creating leakage problems. The application of some accessories can limit these assembly possibilities: the various solutions to be adopted will be explained in the relevant paragraphs.

Start-up

All screw jacks undergo a careful quality examination before being delivered to the client, and are dynamically tested load-free. When starting-up a machine where screw jacks are installed, it is critical to check for the lubrication of the threaded spindles and for the absence of foreign material. During the calibration phase of the electrical end-of-stroke systems, the inertia of the moving masses should be taken into account, which for vertical loads will be lower in ascent and greater in descent. It is advisable to start-up the machine with the minimum possible load and to make sure all components are working properly, before assuming regular operation.

Especially at start-up, it is critical to follow the instructions given in the manual: continuous or hazardous testing maneuvers could lead to an abnormal overheating of the screw jacks and cause irreparable damages.

One single temperature peak is enough to cause premature wear or breakdown of the screw jack.



Routine maintenance

Screw jacks must be periodically inspected, depending on the level of use and working environment. It is advisable to check for lubricant leakages from the casing, and, if this occurs, it is necessary to find and eliminate the cause and fill the lubricant up the correct level.

The lubrication conditions of the threaded spindle must be periodically inspected (and restored if necessary) as well as the presence of any foreign material. The safety components must be inspected according to the applicable norms.

Storage

Screw jacks must be protected from deposits of dust and foreign matter during storage. Particular attention must be paid to saline or corrosive atmospheres.

We also recommend to:

- 1 - Periodically rotate the input shaft to ensure proper lubrication of the inner parts and avoid that the seals dry up, therefore causing lubricant leakages.
- 2 - Lubricate and protect the threaded spindle, the worm screw and the non varnished components.
- 3 - Support the threaded spindle in case of horizontal storage.

Warranty

Warranty is valid given when the instructions contained in our manual are carefully followed.

ORDERING CODES

TP	306	1/5	1000	TF	PR-PE	B	IEC 80B5	SU-P0
model (TP/TPR) (MTP/MTPR)	size	reduction ratio	stroke [mm]	end fitting	protections	construction model	motor flange	accessories

TP MODEL

- 1 Casing
- 2 Cover
- 3 Guide bushing
- 4 Worm wheel
- 5 Worm screw
- 5.1 Motor worm screw right-handed
- 6 Threaded spindle
- 8 Worm screw bearing
- 8.1 Motor worm screw bearing
- 9 Worm wheel bearings
- 10 Seal
- 11 Seal
- 12 Seal
- 13 Snap ring
- 13.1 Snap ring for motoring
- 14 Seal
- 14.1 Seal for motoring
- 15 Rigid protection
- 16 Key
- 17 Dowel
- 18 End fitting elastic fastening pin
- 19 Plug
- 20 Elastic protection
- 21 End fitting
- 22 Motor flange
- 23 Screws

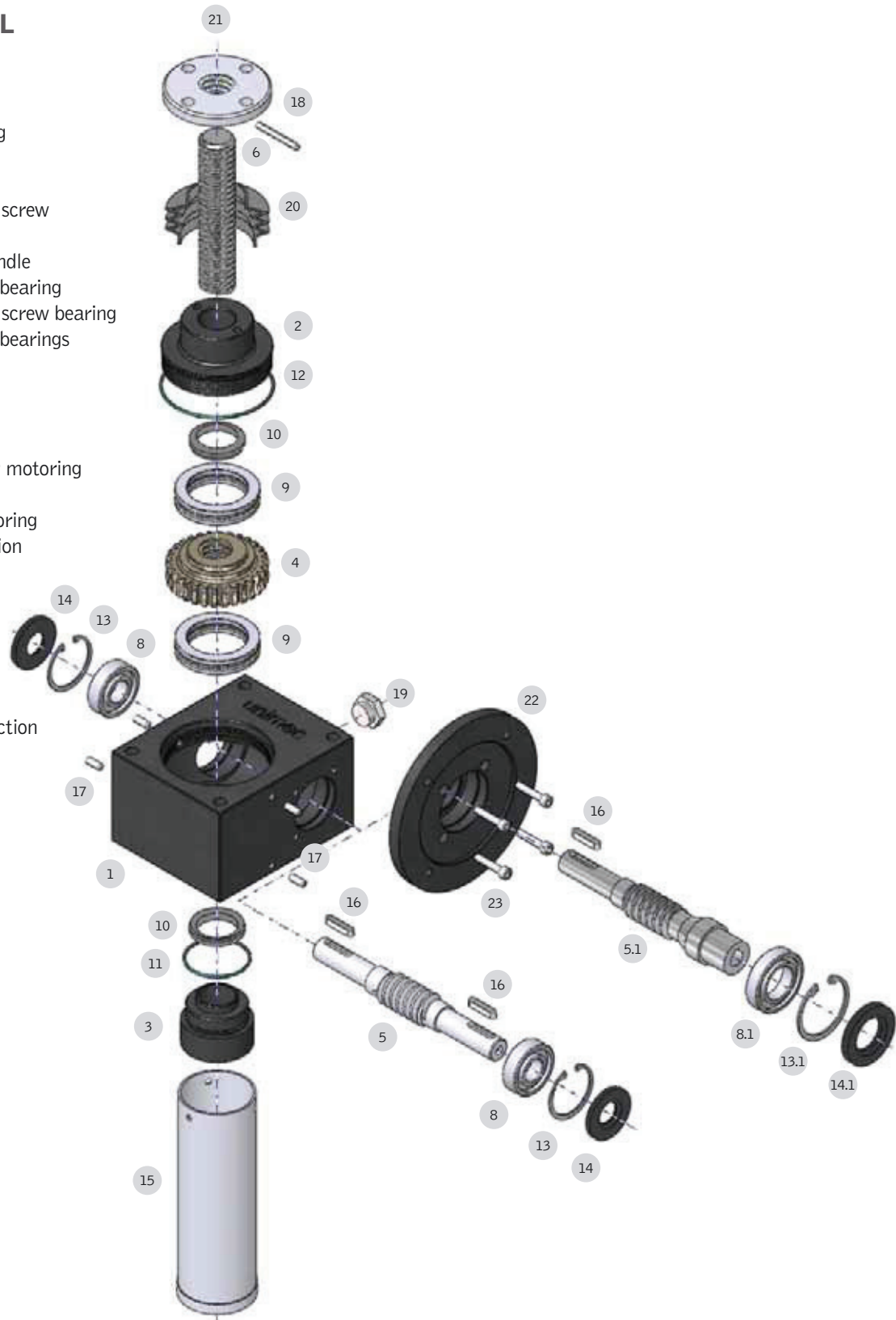

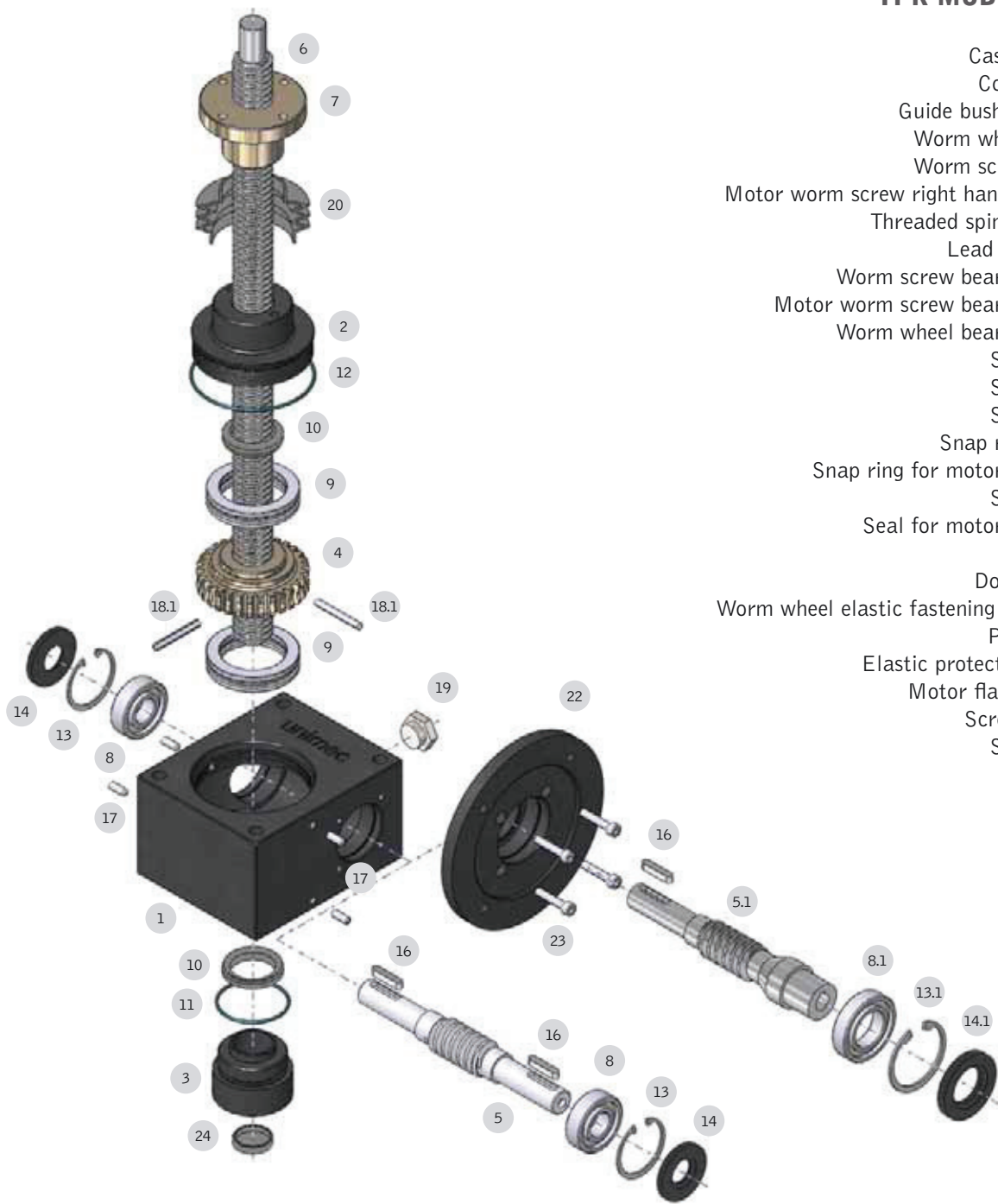

TPR MODEL

Casing	1
Cover	2
Guide bushing	3
Worm wheel	4
Worm screw	5
Motor worm screw right handed	5.1
Threaded spindle	6
Lead nut	7
Worm screw bearing	8
Motor worm screw bearing	8.1
Worm wheel bearing	9
Seal	10
Seal	11
Seal	12
Snap ring	13
Snap ring for motoring	13.1
Seal	14
Seal for motoring	14.1
Key	16
Dowel	17
Worm wheel elastic fastening pin	18.1
Plug	19
Elastic protection	20
Motor flange	22
Screws	23
Seal	24

DIMENSIONING OF THE SCREW JACK

For a correct dimensioning of the screw jack it is necessary to observe the following steps:

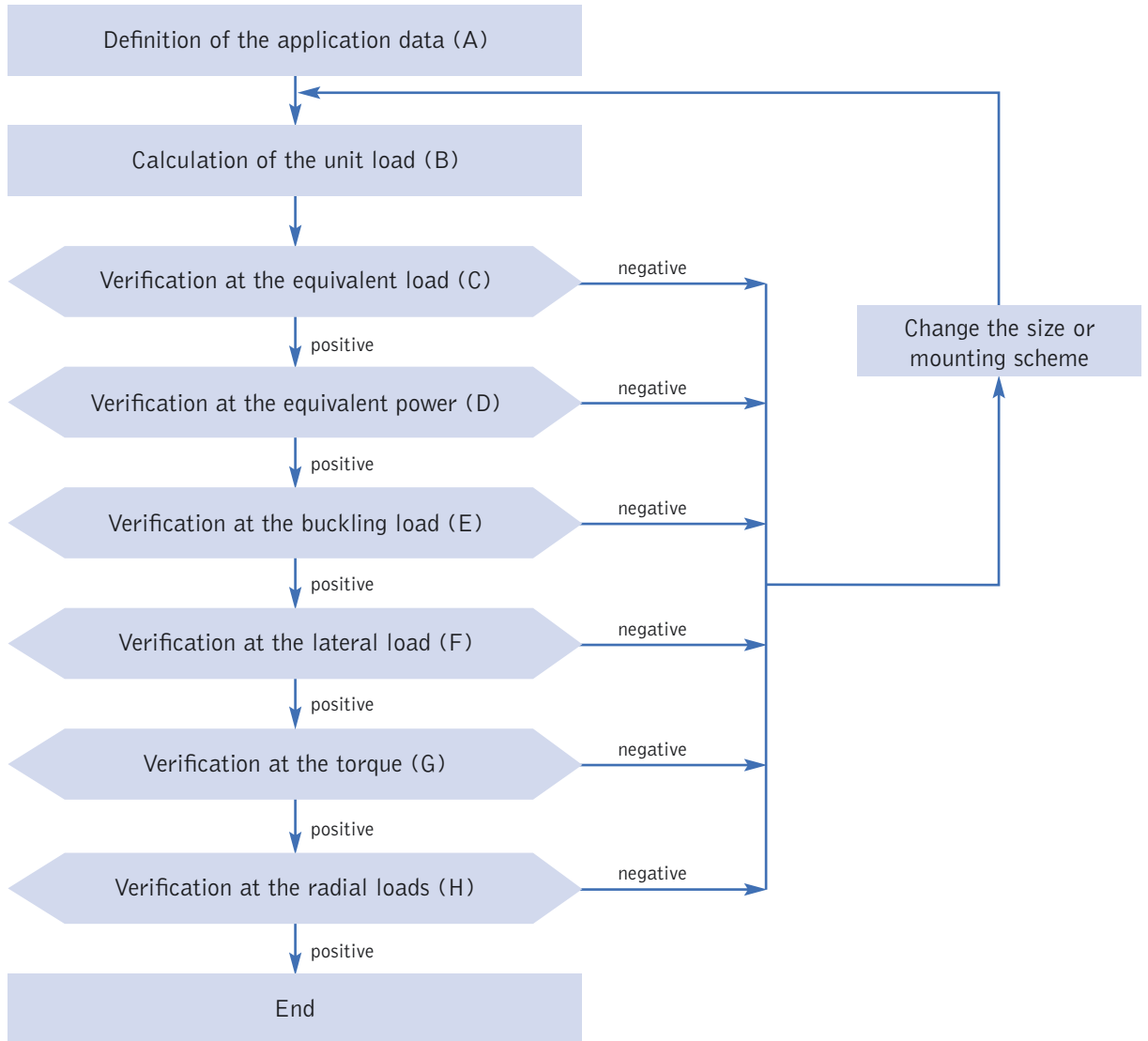

DESCRIPTIVE TABLE

Size		183	204	306	407	559	7010	8010
Admissible load [daN]		500	1000	2500	5000	10000	20000	25000
Trapezoidal spindle: diameter per pitch [mm]		18x3	20x4	30x6	40x7	55x9	70x10	80x10
Theoretical reduction ratio	Fast	1/5	1/5	1/5	1/5	1/5	1/5	1/5
	Normal	1/20	1/10	1/10	1/10	1/10	1/10	1/10
	Slow	-	1/30	1/30	1/30	1/30	1/30	1/30
Real reduction ratio	Fast	4/20	4/19	4/19	6/30	6/30	5/26	5/26
	Normal	1/20	2/21	3/29	3/30	3/30	3/29	3/29
	Slow	-	1/30	1/30	1/30	1/30	1/30	1/30
Spindle stroke for a turn of the worm wheel [mm]		3	4	6	7	9	10	10
Spindle stroke for a turn of the worm screw [mm]	Fast	0,6	0,8	1,2	1,4	1,8	2,0	2,0
	Normal	0,15	0,4	0,6	0,7	0,9	1,0	1,0
	Slow	-	0,13	0,2	0,23	0,3	0,33	0,33
Running efficiency [%]	Fast	29	31	30	28	25	23	22
	Normal	24	28	26	25	22	21	20
	Slow	-	20	18	18	17	14	14
Operation temperature [°C]		-10 / 80 (for different conditions please contact our technical office)						
Weight of the trapezoidal screw for 100 mm [kg]		0,16	0,22	0,5	0,9	1,8	2,8	3,7
Weight of the screw jack (screw not included) [kg]		1,8	5,9	10	18	34	56	62



A - THE APPLICATION DATA

For a right dimensioning of the screw jacks it is necessary to identify the application data:

LOAD [daN] = the load is identified with the force applied to the translating device of a screw jack. Normally the dimensioning is calculated considering the maximum applicable load (worst case). It is important to consider the load as a vector, which is defined by a modulus, a direction and a sense: the modulus quantifies the force, the direction orients spatially and gives indications on the eccentricity or on possible lateral loads, the sense identifies the traction or compression load.

TRANSLATION SPEED [mm/min] = the translation speed is the load handling speed. From this speed it is possible to calculate the rotation speed of the rotating devices and the necessary power for the movement. Wear phenomena and the life of the screw jack proportionally depend on the value of the translation speed. Therefore, it is advisable to limit the translation speed in a way not to exceed the input speed of 1500 rpm on the worm screw. Input speeds up to 3000 rpm are possible but in such case we suggest contacting our technical office.

STROKE [mm] = it is the linear measure used to handle a load. It does not always coincide with the total length of the threaded spindle.

AMBIENT VARIABLES = these values identify the environment and the operating conditions of the screw jack. Among them: temperature, oxidizing and corrosive factors, working and non-working periods, vibrations, maintenance and cleaning, lubrication quality and quantity etc.

MOUNTING SCHEMES = There are several ways of handling a load by means of screw jacks. The schemes on pages 90-91 will show you some examples. Choosing a mounting scheme will condition the choice for the size and the power which is necessary for the application.

B - THE UNIT LOAD AND THE DESCRIPTIVE TABLES

According to the n number of screw jacks contained in the mounting scheme it is possible to calculate each screw jack's load by dividing the total load by n. In case the load is not fairly distributed in all screw jacks, it is recommended to consider the transmission having the heaviest load, by virtue of a dimensioning based on the worst case.

9010	10012	12014	14014	16016	20018	25022	Size
35000	40000	60000	80000	100000	150000	200000	Admissible load [daN]
100x12	100x12	120x14	140x14	160x16	200x18	250x22	Trapezoidal spindle: diameter per pitch [mm]
-	-	-	-	-	-	-	Fast Theoretical reduction ratio
1/10	1/10	1/10	1/12	1/12	1/12	1/12	Normal
1/30	1/30	1/30	1/36	1/36	1/36	1/36	Slow
-	-	-	-	-	-	-	Fast Real reduction ration
3/30	3/31	3/31	3/36	3/36	3/36	3/36	Normal
1/30	1/30	1/30	1/36	1/36	1/36	1/36	Slow
12	12	14	14	16	18	22	Spindle stroke for a turn of the worm wheel [mm]
-	-	-	-	-	-	-	Spindle stroke for a turn of the worm screw fast [mm]
1,2	1,2	1,4	1,16	1,33	1,5	1,83	Normal
0,4	0,4	0,47	0,38	0,44	0,5	0,61	Slow
-	-	-	-	-	-	-	Fast Running efficiency [%]
18	18	17	16	15	14	14	Normal
12	12	11	10	9	9	9	Slow
							Operation temperature [°C]
5,6	5,6	8,1	11	14	22	35	Weight of the trapezoidal screw for 100 mm [kg]
110	180	180	550	550	2100	2100	Weight of the screw jack (screw not included) [kg]

C – THE EQUIVALENT LOAD

All the values listed in the catalogue refer to standard use conditions, i.e. under a temperature of 20 °C and working percentage of 10%.

For different operation conditions the equivalent load should be calculated: it refers to the load which would be applied in standard conditions in order to have the same thermal exchange and wear effects, which the real load achieves in the real conditions of use.

It is therefore advisable to calculate the equivalent load according to the following formula:

$$C_e = C \cdot f_t \cdot f_a \cdot f_s$$

The temperature factor f_t

By means of the following diagram an f_t factor can be calculated according to the ambient temperature. In case of temperatures higher than 80 °C we suggest contacting our technical office.

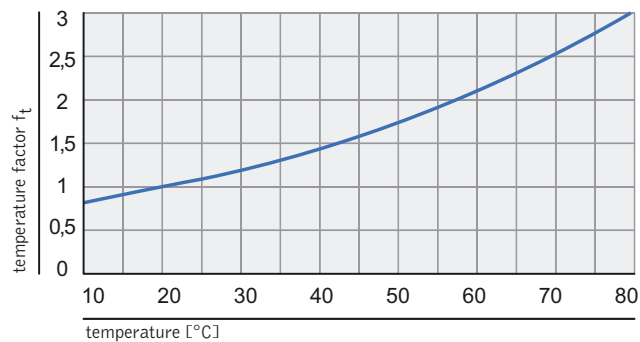

The ambient factor f_a

By means of the following table it is possible to calculate the f_a factor according to the operation conditions.

Type of load	Ambient factor f_a
Light shocks, few insertions, regular movements	1
Medium shocks, frequent insertions, regular movements	1,2
High shocks, many insertions, irregular movements	1,8



The service factor f_s

The service factor f_s is obtained by evaluating the working cycle and calculating the operation percentage on that interval. For example a working time of 10 minutes and non working time of 10 minutes correspond to 50%; similarly a working time of 5 minutes and a non working time of 20 minutes correspond to 20%. Based on the working data, choosing the cycle time and the operation percentage it is possible to read the f_s value on the ordinate axis.

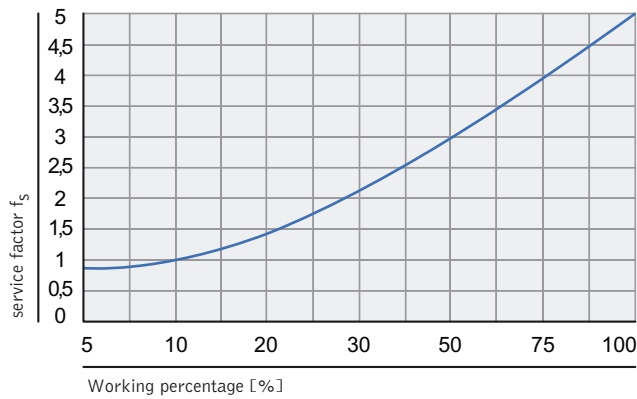

With the aid of the descriptive tables it is possible to check whether the previously chosen size is able to support an admissible dynamic load equal to the equivalent load. If not, it is necessary to effect a second choice.

D – THE POWER TABLES AND THE EQUIVALENT POWER

The power tables are listed from page 46 to page 59. Choosing the tables referring to the size selected in paragraph C and putting the equivalent load values as well as the translation speed values in the table, it is possible to obtain the equivalent power P_e value. If the crossing values fall into the coloured area, this means that the application conditions could cause negative phenomena such as overheating and strong wear. It is therefore necessary to reduce the translation speed or to increase the size.

The equivalent power is not the power requested by the single screw jack, unless the three correction factors f_t , f_a and f_s have a unit value.

E – BUCKLING

In case of compression load, even occasional, it is necessary to check the buckling structure.

Firstly the two constraints which support the screw jack have to be determined: the first one is on the end fitting for TP models and on the lead nut for TPR models, while the second one is the way the casing is grounded.

Most part of the real cases can be schematized according to three models, as listed below:

	End fitting – lead nut	Screw jack
Euler I	Free	Fitted in
Euler II	Hinge	Hinge
Euler III	Sleeve	Fitted in

Once the Euler case has been determined which most fits to the current application, it is necessary to find in the corresponding diagram the point corresponding to the coordinates (length; load). The sizes suited to the application are those whose curves subtend the above point. In case the size chosen at paragraph D does not meet such requisites it is necessary to choose a higher size. The Euler-Gordon-Rankine curves have been calculated with a factor of safety equal to 4. For applications which can support factors of safety lower than 4 we suggest contacting our technical office.

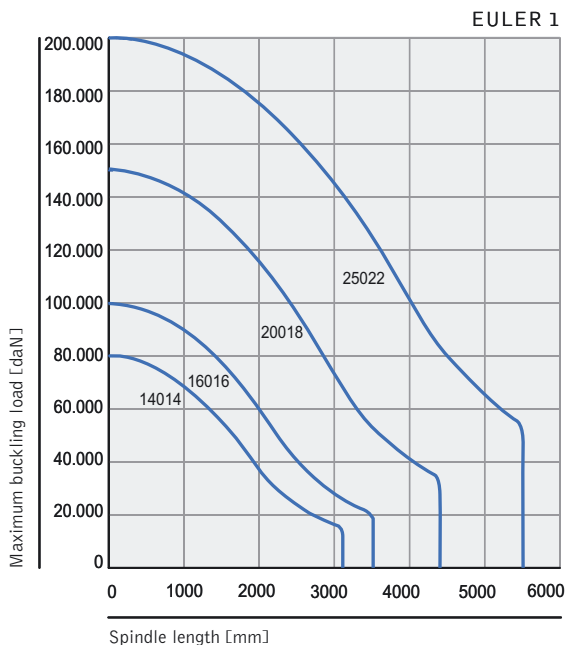
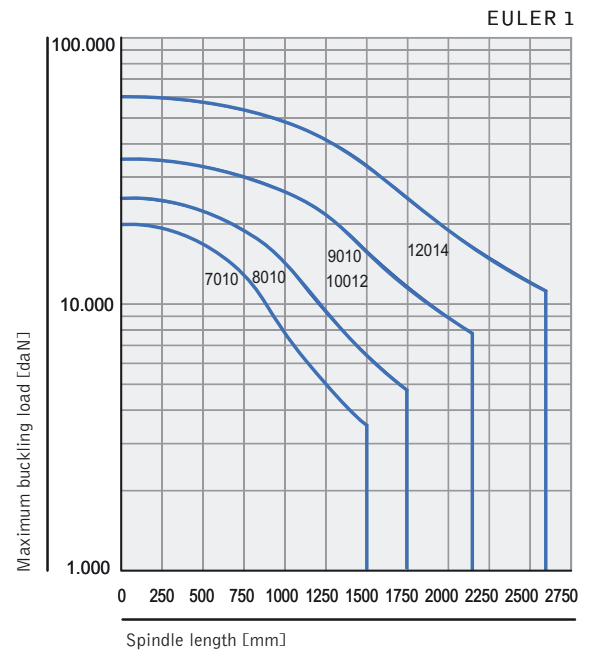
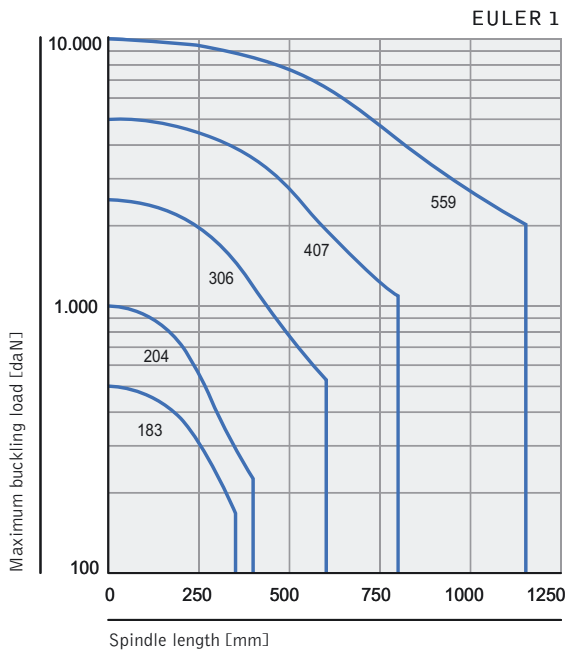

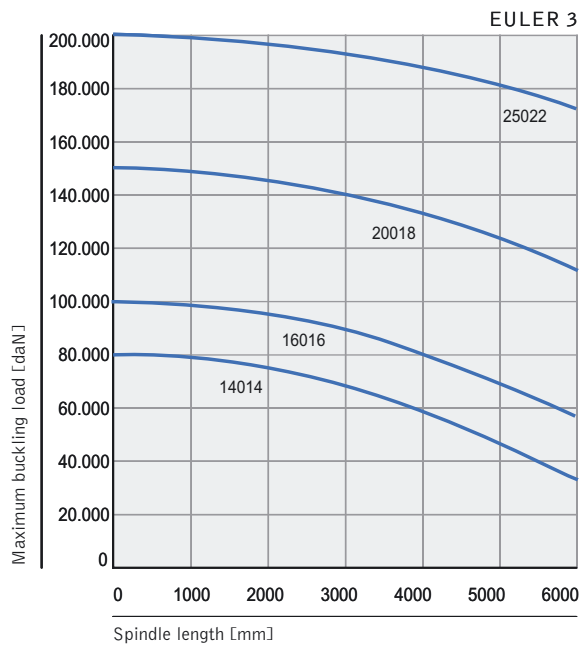
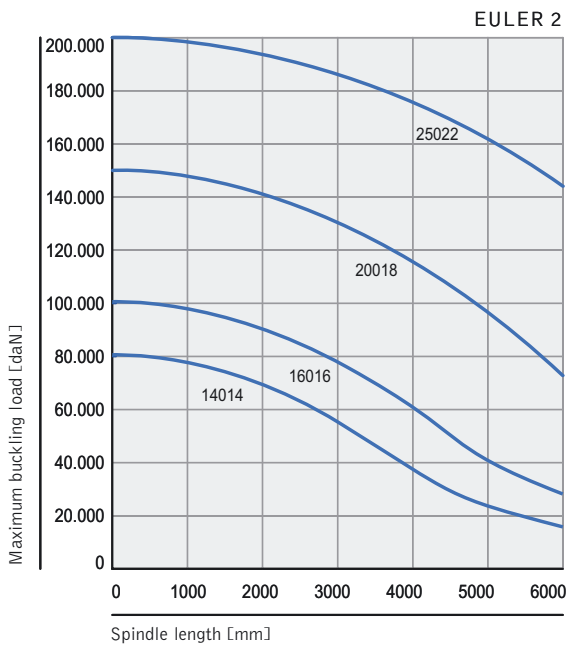
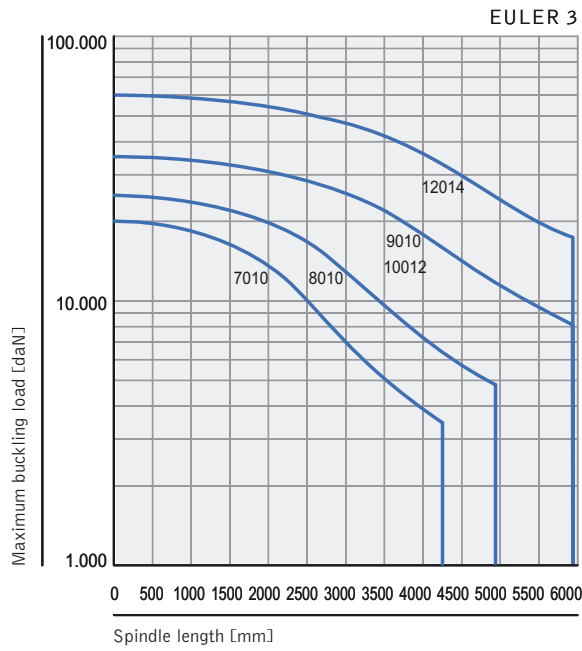
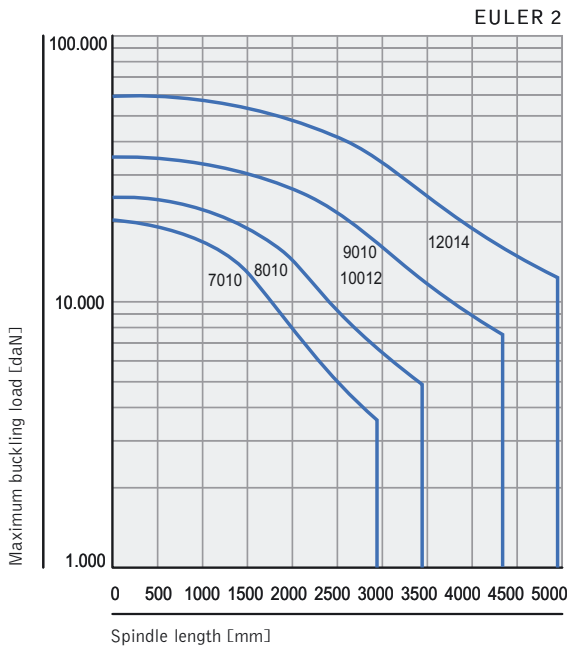
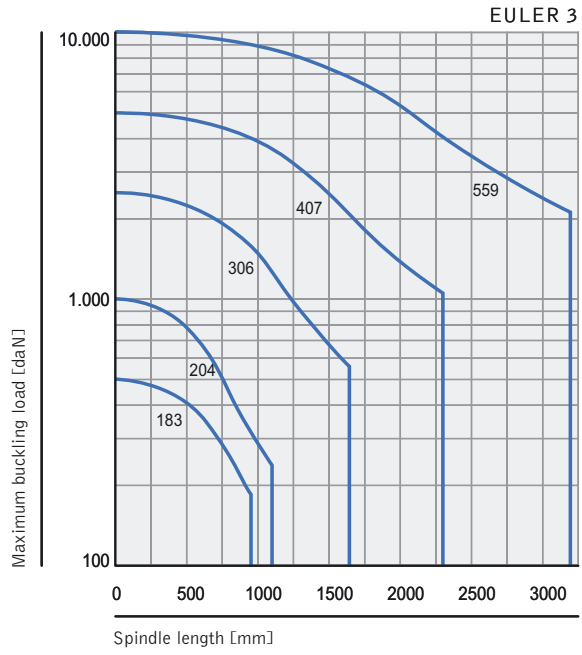
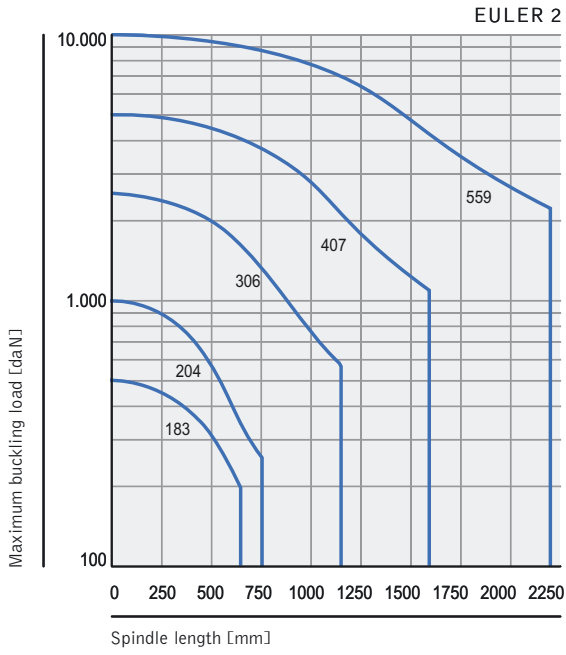

F – THE LATERAL LOAD

As stated in the previous paragraphs lateral loads are the main cause of failures. In addition to the misalignment of the threaded spindle and the load, they can be caused by inaccurate mountings which force the threaded spindle in an anomalous position. As a consequence the coupling between lead nut and threaded spindle for TPR model and between the threaded spindle and the worm wheel for the TP model will be wrong. The application of double serial guides allows, for TP models, a partial correction of the anomalous position of the threaded spindle before contacting the worm wheel. The problem is transformed into a sliding of the threaded spindle on the guides themselves. In TPR model, it is the outer support nut which contacts the threaded spindle and it is therefore not possible to apply any corrections, unless particular mountings are applied as illustrated in the paragraph "lateral backlash in TPR models". Lateral loads can even derive from an horizontal mounting: the threaded spindle own weight causes a bending of the same, becoming in this way a lateral load. The border value for the bending and the consequent lateral load depends on the screw jack size and on the threaded spindle length. It is advisable to contact our technical office in order to foresee the suitable supports.

The following diagrams, which are valid for static loads, show the admissible lateral load value, according to the size and the length of the threaded spindle. For dynamic applications it is necessary to ask to the technical office.

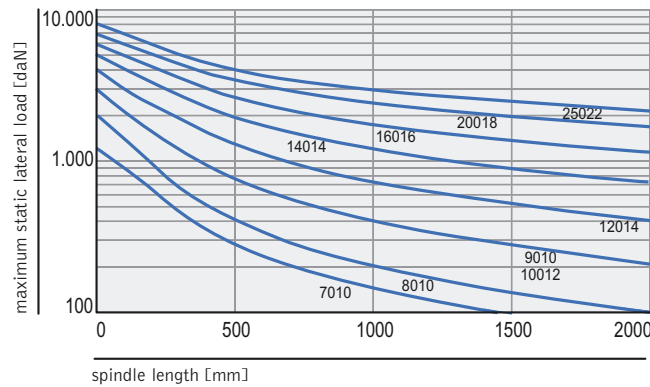
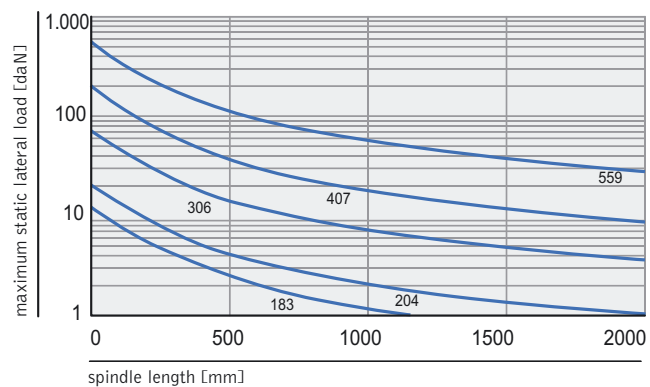

In case the size chosen in the previous paragraphs is not enough to support a particular lateral load, a suitable size should be chosen.

G – THE TORQUE

At this stage it is possible to calculate the power requested by the mounting. The following formula will be used to calculate this value:

$$P = \frac{1}{1000} \cdot \frac{n \cdot C \cdot v}{6000 \cdot \eta_m \cdot \eta_c \cdot \eta_s}$$

where:

P = requested power [kW]

n = number of screw jacks

C = unit load [daN]

v = translation speed [mm/min]

η_m = screw jack running efficiency (see descriptive tables)

η_c = configuration running efficiency = $1 - [(N-1) \cdot 0,05]$, where N is the total number of screw jacks and gear boxes

η_s = structure running efficiency (guides, belts, pulleys, shafts, joints, reducers)



In order to complete the calculation of the requested power it is necessary to calculate the torque which should be transmitted by the drive shaft:

$$M_{tm} = \frac{955 \cdot P}{\omega_m}$$

where:

- M_{tm} = is the torque on the drive shaft [daNm]
- P = is the motor power [kW]
- ω_m = is the angular speed of the motor [rpm]

According to the applied mounting scheme it is necessary to check that the worm screw will be able to hold out under a possible combined torque. In the following table the admissible torque values are listed for the worm screws according to their size and expressed as [daNm].



Size	183	204	306	407	559	7010	8010	9010	10012	12014	14014	16016	20018	25022
Fast ratio [daNm]	2,30	5,43	6,90	49,0	49,0	84,7	84,7	-	-	-	-	-	-	-
Normal ratio [daNm]	2,30	5,43	15,4	12,8	12,8	84,7	84,7	202	522	522	823	823	2847	2847
Slow ratio [daNm]	-	4,18	18,3	15,4	15,4	49,0	49,0	202	441	441	984	984	2847	2847

In case the above values are exceeded it will be necessary to choose a higher size, to change the mounting scheme or to increase the speed, in accordance to what has been indicated in the previous paragraphs.

H - RADIAL LOADS

In case of radial loads on the worm screw it is necessary to check their strength according to the following table:



Size	183	204	306	407	559	7010	8010	9010	10012	12014	14014	16016	20018	25022
F_{rv} [daN]	10	22	45	60	60	90	90	100	250	250	300	300	380	380

In case the above values are exceeded it will be necessary to choose a higher size, to change the mounting scheme or to increase the speed, in accordance to what has been indicated in the previous paragraphs.

Size 183

Load [daN]		Ratio 1/5											
		500		400		300		200		100		50	
Worm screw rotation speed ω_v [rpm]	Threaded spindle translation speed v [mm/min]	P_i [kW]	M_{tv} [daNm]	P_i [kW]	M_{tv} [daNm]	P_i [kW]	M_{tv} [daNm]	P_i [kW]	M_{tv} [daNm]	P_i [kW]	M_{tv} [daNm]	P_i [kW]	M_{tv} [daNm]
1500	900	0,25	0,17	0,21	0,14	0,15	0,10	0,10	0,07	0,07	0,03	0,07	0,03
1000	600	0,17	0,17	0,14	0,14	0,10	0,10	0,07	0,07	0,07	0,03	0,07	0,03
750	450	0,13	0,17	0,10	0,14	0,08	0,10	0,07	0,07	0,07	0,03	0,07	0,03
500	300	0,09	0,17	0,07	0,14	0,07	0,10	0,07	0,07	0,07	0,03	0,07	0,03
300	180	0,07	0,17	0,07	0,14	0,07	0,10	0,07	0,07	0,07	0,03	0,07	0,03
100	60	0,07	0,17	0,07	0,14	0,07	0,10	0,07	0,07	0,07	0,03	0,07	0,03
50	30	0,07	0,17	0,07	0,14	0,07	0,10	0,07	0,07	0,07	0,03	0,07	0,03

Load [daN]		Ratio 1/20											
		500		400		300		200		100		50	
Worm screw rotation speed ω_v [rpm]	Threaded spindle translation speed v [mm/min]	P_i [kW]	M_{tv} [daNm]	P_i [kW]	M_{tv} [daNm]	P_i [kW]	M_{tv} [daNm]	P_i [kW]	M_{tv} [daNm]	P_i [kW]	M_{tv} [daNm]	P_i [kW]	M_{tv} [daNm]
1500	225	0,08	0,06	0,07	0,05	0,07	0,04	0,07	0,04	0,07	0,04	0,07	0,04
1000	150	0,07	0,06	0,07	0,05	0,07	0,04	0,07	0,04	0,07	0,04	0,07	0,04
750	112,5	0,07	0,06	0,07	0,05	0,07	0,04	0,07	0,04	0,07	0,04	0,07	0,04
500	75	0,07	0,06	0,07	0,05	0,07	0,04	0,07	0,04	0,07	0,04	0,07	0,04
300	45	0,07	0,06	0,07	0,05	0,07	0,04	0,07	0,04	0,07	0,04	0,07	0,04
100	15	0,07	0,06	0,07	0,05	0,07	0,04	0,07	0,04	0,07	0,04	0,07	0,04
50	7,5	0,07	0,06	0,07	0,05	0,07	0,04	0,07	0,04	0,07	0,04	0,07	0,04



Size 204

Ratio 1/5															
Load [daN]		1000		800		600		400		300		200		100	
Worm screw rotation speed ω_v [rpm]	Threaded spindle translation speed v [mm/min]	P_i [kW]	M_{tv} [daNm]	P_i [kW]	M_{tv} [daNm]	P_i [kW]	M_{tv} [daNm]	P_i [kW]	M_{tv} [daNm]	P_i [kW]	M_{tv} [daNm]	P_i [kW]	M_{tv} [daNm]	P_i [kW]	M_{tv} [daNm]
1500	1200	0,64	0,42	0,51	0,33	0,38	0,25	0,26	0,17	0,19	0,13	0,13	0,09	0,07	0,05
1000	800	0,43	0,42	0,34	0,33	0,26	0,25	0,17	0,17	0,13	0,13	0,09	0,09	0,07	0,05
750	600	0,32	0,42	0,26	0,33	0,19	0,25	0,13	0,17	0,10	0,13	0,07	0,09	0,07	0,05
500	400	0,21	0,42	0,17	0,33	0,13	0,25	0,09	0,17	0,07	0,13	0,07	0,09	0,07	0,05
300	240	0,13	0,42	0,11	0,33	0,11	0,25	0,07	0,17	0,07	0,13	0,07	0,09	0,07	0,05
100	80	0,07	0,42	0,07	0,33	0,07	0,25	0,07	0,17	0,07	0,13	0,07	0,09	0,07	0,05
50	40	0,07	0,42	0,07	0,33	0,07	0,25	0,07	0,17	0,07	0,13	0,07	0,09	0,07	0,05

Ratio 1/10															
Load [daN]		1000		800		600		400		300		200		100	
Worm screw rotation speed ω_v [rpm]	Threaded spindle translation speed v [mm/min]	P_i [kW]	M_{tv} [daNm]	P_i [kW]	M_{tv} [daNm]	P_i [kW]	M_{tv} [daNm]	P_i [kW]	M_{tv} [daNm]	P_i [kW]	M_{tv} [daNm]	P_i [kW]	M_{tv} [daNm]	P_i [kW]	M_{tv} [daNm]
1500	600	0,36	0,23	0,30	0,19	0,22	0,14	0,14	0,09	0,11	0,07	0,08	0,05	0,07	0,03
1000	400	0,24	0,23	0,20	0,19	0,14	0,14	0,09	0,09	0,07	0,07	0,07	0,05	0,07	0,03
750	300	0,18	0,23	0,15	0,19	0,11	0,14	0,07	0,09	0,07	0,07	0,07	0,05	0,07	0,03
500	200	0,12	0,23	0,10	0,19	0,07	0,14	0,07	0,09	0,07	0,07	0,07	0,05	0,07	0,03
300	120	0,07	0,23	0,07	0,19	0,07	0,14	0,07	0,09	0,07	0,07	0,07	0,05	0,07	0,03
100	40	0,07	0,23	0,07	0,19	0,07	0,14	0,07	0,09	0,07	0,07	0,07	0,05	0,07	0,03
50	20	0,07	0,23	0,07	0,19	0,07	0,14	0,07	0,09	0,07	0,07	0,07	0,05	0,07	0,03

Ratio 1/30															
Load [daN]		1000		800		600		400		300		200		100	
Worm screw rotation speed ω_v [rpm]	Threaded spindle translation speed v [mm/min]	P_i [kW]	M_{tv} [daNm]	P_i [kW]	M_{tv} [daNm]	P_i [kW]	M_{tv} [daNm]	P_i [kW]	M_{tv} [daNm]	P_i [kW]	M_{tv} [daNm]	P_i [kW]	M_{tv} [daNm]	P_i [kW]	M_{tv} [daNm]
1500	200	0,17	0,11	0,13	0,08	0,11	0,07	0,07	0,05	0,07	0,03	0,07	0,03	0,07	0,03
1000	133	0,12	0,11	0,08	0,08	0,07	0,07	0,07	0,05	0,07	0,03	0,07	0,03	0,07	0,03
750	100	0,08	0,11	0,07	0,08	0,07	0,07	0,07	0,05	0,07	0,03	0,07	0,03	0,07	0,03
500	67	0,07	0,11	0,07	0,08	0,07	0,07	0,07	0,05	0,07	0,03	0,07	0,03	0,07	0,03
300	40	0,07	0,11	0,07	0,08	0,07	0,07	0,07	0,05	0,07	0,03	0,07	0,03	0,07	0,03
100	13	0,07	0,11	0,07	0,08	0,07	0,07	0,07	0,05	0,07	0,03	0,07	0,03	0,07	0,03
50	6,7	0,07	0,11	0,07	0,08	0,07	0,07	0,07	0,05	0,07	0,03	0,07	0,03	0,07	0,03

Size 306

Ratio 1/5															
Load [daN]		2500		2000		1500		1000		750		500		250	
Worm screw rotation speed ω_v [rpm]	Threaded spindle translation speed v [mm/min]	P _i	M _{tv}	P _i	M _{tv}	P _i	M _{tv}	P _i	M _{tv}	P _i	M _{tv}	P _i	M _{tv}	P _i	M _{tv}
		[kW]	[daNm]	[kW]	[daNm]	[kW]	[daNm]	[kW]	[daNm]	[kW]	[daNm]	[kW]	[daNm]	[kW]	[daNm]
1500	1800	2,45	1,60	1,96	1,28	1,47	0,96	0,98	0,64	0,74	0,48	0,49	0,32	0,25	0,17
1000	1200	1,64	1,60	1,31	1,28	0,98	0,96	0,65	0,64	0,49	0,48	0,33	0,32	0,17	0,17
750	900	1,23	1,60	0,98	1,28	0,74	0,96	0,49	0,64	0,37	0,48	0,25	0,32	0,13	0,17
500	600	0,82	1,60	0,66	1,28	0,49	0,96	0,33	0,64	0,25	0,48	0,17	0,32	0,10	0,17
300	360	0,49	1,60	0,40	1,28	0,30	0,96	0,20	0,64	0,15	0,48	0,10	0,32	0,10	0,17
100	120	0,17	1,60	0,13	1,28	0,10	0,96	0,10	0,64	0,10	0,48	0,10	0,32	0,10	0,17
50	60	0,10	1,60	0,10	1,28	0,10	0,96	0,10	0,64	0,10	0,48	0,10	0,32	0,10	0,17

Ratio 1/10															
Load [daN]		2500		2000		1500		1000		750		500		250	
Worm screw rotation speed ω_v [rpm]	Threaded spindle translation speed v [mm/min]	P _i	M _{tv}	P _i	M _{tv}	P _i	M _{tv}	P _i	M _{tv}	P _i	M _{tv}	P _i	M _{tv}	P _i	M _{tv}
		[kW]	[daNm]	[kW]	[daNm]	[kW]	[daNm]	[kW]	[daNm]	[kW]	[daNm]	[kW]	[daNm]	[kW]	[daNm]
1500	900	1,43	0,93	1,14	0,74	0,86	0,56	0,57	0,37	0,43	0,28	0,29	0,19	0,16	0,10
1000	600	0,96	0,93	0,76	0,74	0,58	0,56	0,38	0,37	0,29	0,28	0,20	0,19	0,10	0,10
750	450	0,72	0,93	0,57	0,74	0,43	0,56	0,29	0,37	0,22	0,28	0,15	0,19	0,10	0,10
500	300	0,48	0,93	0,38	0,74	0,28	0,56	0,19	0,37	0,15	0,28	0,10	0,19	0,10	0,10
300	180	0,28	0,93	0,23	0,74	0,18	0,56	0,12	0,37	0,10	0,28	0,10	0,19	0,10	0,10
100	60	0,10	0,93	0,10	0,74	0,10	0,56	0,10	0,37	0,10	0,28	0,10	0,19	0,10	0,10
50	30	0,10	0,93	0,10	0,74	0,10	0,56	0,10	0,37	0,10	0,28	0,10	0,19	0,10	0,10

Ratio 1/30															
Load [daN]		2500		2000		1500		1000		750		500		250	
Worm screw rotation speed ω_v [rpm]	Threaded spindle translation speed v [mm/min]	P _i	M _{tv}	P _i	M _{tv}	P _i	M _{tv}	P _i	M _{tv}	P _i	M _{tv}	P _i	M _{tv}	P _i	M _{tv}
		[kW]	[daNm]	[kW]	[daNm]	[kW]	[daNm]	[kW]	[daNm]	[kW]	[daNm]	[kW]	[daNm]	[kW]	[daNm]
1500	300	0,68	0,44	0,56	0,36	0,42	0,27	0,28	0,18	0,22	0,14	0,14	0,09	0,07	0,05
1000	200	0,45	0,44	0,37	0,36	0,28	0,27	0,19	0,18	0,14	0,14	0,10	0,09	0,07	0,05
750	150	0,34	0,44	0,28	0,36	0,21	0,27	0,14	0,18	0,11	0,14	0,07	0,09	0,07	0,05
500	100	0,23	0,44	0,19	0,36	0,14	0,27	0,10	0,18	0,07	0,14	0,07	0,09	0,07	0,05
300	60	0,14	0,44	0,11	0,36	0,08	0,27	0,07	0,18	0,07	0,14	0,07	0,09	0,07	0,05
100	20	0,07	0,44	0,11	0,36	0,08	0,27	0,07	0,18	0,07	0,14	0,07	0,09	0,07	0,05
50	10	0,07	0,44	0,11	0,36	0,08	0,27	0,07	0,18	0,07	0,14	0,07	0,09	0,07	0,05



Size 407

Ratio 1/5															
Load [daN]		5000		4000		3000		2000		1500		1000		500	
Worm screw rotation speed ω_v [rpm]	Threaded spindle translation speed v [mm/min]	P_i [kW]	M_{tv} [daNm]	P_i [kW]	M_{tv} [daNm]	P_i [kW]	M_{tv} [daNm]	P_i [kW]	M_{tv} [daNm]	P_i [kW]	M_{tv} [daNm]	P_i [kW]	M_{tv} [daNm]	P_i [kW]	M_{tv} [daNm]
1500	2100	6,13	3,98	4,90	3,18	3,68	2,39	2,45	1,59	1,84	1,20	1,23	0,80	0,62	0,40
1000	1400	4,09	3,98	3,27	3,18	2,15	2,39	1,64	1,59	1,23	1,20	0,82	0,80	0,41	0,40
750	1050	3,06	3,98	2,45	3,18	1,80	2,39	1,23	1,59	0,92	1,20	0,62	0,80	0,31	0,40
500	700	2,04	3,98	1,64	3,18	1,23	2,39	0,82	1,59	0,62	1,20	0,41	0,80	0,21	0,40
300	420	1,23	3,98	0,98	3,18	0,74	2,39	0,49	1,59	0,37	1,20	0,25	0,80	0,13	0,40
100	140	0,41	3,98	0,33	3,18	0,25	2,39	0,17	1,59	0,13	1,20	0,10	0,80	0,10	0,40
50	70	0,21	3,98	0,17	3,18	0,13	2,39	0,10	1,59	0,10	1,20	0,10	0,80	0,10	0,40

Ratio 1/10															
Load [daN]		5000		4000		3000		2000		1500		1000		500	
Worm screw rotation speed ω_v [rpm]	Threaded spindle translation speed v [mm/min]	P_i [kW]	M_{tv} [daNm]	P_i [kW]	M_{tv} [daNm]	P_i [kW]	M_{tv} [daNm]	P_i [kW]	M_{tv} [daNm]	P_i [kW]	M_{tv} [daNm]	P_i [kW]	M_{tv} [daNm]	P_i [kW]	M_{tv} [daNm]
1500	1050	3,60	2,30	2,80	1,80	2,10	1,34	1,40	0,90	1,05	0,67	0,70	0,45	0,35	0,23
1000	700	2,40	2,30	1,85	1,80	1,38	1,34	0,92	0,90	0,69	0,67	0,46	0,45	0,23	0,23
750	525	1,77	2,30	1,40	1,80	1,00	1,34	0,70	0,90	0,52	0,67	0,35	0,45	0,18	0,23
500	350	1,18	2,30	0,92	1,80	0,69	1,34	0,46	0,90	0,35	0,67	0,23	0,45	0,12	0,23
300	210	0,71	2,30	0,56	1,80	0,42	1,34	0,28	0,90	0,21	0,67	0,14	0,45	0,10	0,23
100	70	0,24	2,30	0,19	1,80	0,14	1,34	0,10	0,90	0,10	0,67	0,10	0,45	0,10	0,23
50	35	0,12	2,30	0,10	1,80	0,10	1,34	0,10	0,90	0,10	0,67	0,10	0,45	0,10	0,23

Ratio 1/30															
Load [daN]		5000		4000		3000		2000		1500		1000		500	
Worm screw rotation speed ω_v [rpm]	Threaded spindle translation speed v [mm/min]	P_i [kW]	M_{tv} [daNm]	P_i [kW]	M_{tv} [daNm]	P_i [kW]	M_{tv} [daNm]	P_i [kW]	M_{tv} [daNm]	P_i [kW]	M_{tv} [daNm]	P_i [kW]	M_{tv} [daNm]	P_i [kW]	M_{tv} [daNm]
1500	350	1,69	1,10	1,26	0,82	0,95	0,62	0,63	0,41	0,48	0,31	0,32	0,21	0,17	0,11
1000	233	1,13	1,10	0,84	0,82	0,64	0,62	0,42	0,41	0,32	0,31	0,21	0,21	0,11	0,11
750	175	0,85	1,10	0,63	0,82	0,48	0,62	0,32	0,41	0,24	0,31	0,16	0,21	0,08	0,11
500	117	0,56	1,10	0,42	0,82	0,32	0,62	0,21	0,41	0,16	0,31	0,11	0,21	0,07	0,11
300	70	0,34	1,10	0,25	0,82	0,19	0,62	0,13	0,41	0,10	0,31	0,07	0,21	0,07	0,11
100	23	0,12	1,10	0,08	0,82	0,07	0,62	0,07	0,41	0,07	0,31	0,07	0,21	0,07	0,11
50	11,7	0,07	1,10	0,07	0,82	0,07	0,62	0,07	0,41	0,07	0,31	0,07	0,21	0,07	0,11

Size 559

Ratio 1/5															
Load [daN]		10000		7500		5000		4000		3000		2000		1000	
Worm screw rotation speed ω_v [rpm]	Threaded spindle translation speed v [mm/min]	P _i	M _{tv}	P _i	M _{tv}	P _i	M _{tv}	P _i	M _{tv}	P _i	M _{tv}	P _i	M _{tv}	P _i	M _{tv}
		[kW]	[daNm]	[kW]	[daNm]	[kW]	[daNm]	[kW]	[daNm]	[kW]	[daNm]	[kW]	[daNm]	[kW]	[daNm]
1500	2700	17,7	11,5	13,3	8,60	8,83	5,74	7,06	4,58	5,30	3,44	3,53	2,29	1,77	1,15
1000	1800	11,8	11,5	8,83	8,60	5,89	5,74	4,71	4,58	3,53	3,44	2,36	2,29	1,18	1,15
750	1350	8,83	11,5	6,62	8,60	4,42	5,74	3,53	4,58	2,65	3,44	1,77	2,29	0,89	1,15
500	900	5,88	11,5	4,42	8,60	2,94	5,74	2,36	4,58	1,77	3,44	1,18	2,29	0,59	1,15
300	540	3,53	11,5	2,65	8,60	1,77	5,74	1,42	4,58	1,06	3,44	0,71	2,29	0,36	1,15
100	180	1,18	11,5	0,88	8,60	0,59	5,74	0,47	4,58	0,36	3,44	0,24	2,29	0,12	1,15
50	90	0,57	11,5	0,44	8,60	0,30	5,74	0,24	4,58	0,18	3,44	0,12	2,29	0,10	1,15

Ratio 1/10															
Load [daN]		10000		7500		5000		4000		3000		2000		1000	
Worm screw rotation speed ω_v [rpm]	Threaded spindle translation speed v [mm/min]	P _i	M _{tv}	P _i	M _{tv}	P _i	M _{tv}	P _i	M _{tv}	P _i	M _{tv}	P _i	M _{tv}	P _i	M _{tv}
		[kW]	[daNm]	[kW]	[daNm]	[kW]	[daNm]	[kW]	[daNm]	[kW]	[daNm]	[kW]	[daNm]	[kW]	[daNm]
1500	1350	10,0	6,50	7,50	4,90	5,00	3,25	4,00	2,60	3,10	2,00	2,00	1,30	1,00	0,65
1000	900	6,70	6,50	5,00	4,90	3,40	3,25	2,70	2,60	2,10	2,00	1,35	1,30	0,67	0,65
750	675	5,00	6,50	3,77	4,90	2,50	3,25	2,00	2,60	1,54	2,00	1,00	1,30	0,50	0,65
500	450	3,30	6,50	2,50	4,90	1,67	3,25	1,33	2,60	1,03	2,00	0,67	1,30	0,33	0,65
300	270	2,00	6,50	1,50	4,90	1,00	3,25	0,80	2,60	0,62	2,00	0,40	1,30	0,20	0,65
100	90	0,67	6,50	0,50	4,90	0,33	3,25	0,27	2,60	0,20	2,00	0,13	1,30	0,10	0,65
50	45	0,33	6,50	0,25	4,90	0,17	3,25	0,13	2,60	0,10	2,00	0,10	1,30	0,10	0,65

Ratio 1/30															
Load [daN]		10000		7500		5000		4000		3000		2000		1000	
Worm screw rotation speed ω_v [rpm]	Threaded spindle translation speed v [mm/min]	P _i	M _{tv}	P _i	M _{tv}	P _i	M _{tv}	P _i	M _{tv}	P _i	M _{tv}	P _i	M _{tv}	P _i	M _{tv}
		[kW]	[daNm]	[kW]	[daNm]	[kW]	[daNm]	[kW]	[daNm]	[kW]	[daNm]	[kW]	[daNm]	[kW]	[daNm]
1500	450	4,30	2,80	3,30	2,10	2,20	1,40	1,73	1,12	1,30	0,84	0,86	0,56	0,43	0,28
1000	300	2,90	2,80	2,16	2,10	1,44	1,40	1,15	1,12	0,86	0,84	0,58	0,56	0,29	0,28
750	225	2,16	2,80	1,62	2,10	1,08	1,40	0,86	1,12	0,65	0,84	0,43	0,56	0,22	0,28
500	150	1,44	2,80	1,10	2,10	0,72	1,40	0,58	1,12	0,43	0,84	0,29	0,56	0,15	0,28
300	90	0,86	2,80	0,65	2,10	0,43	1,40	0,35	1,12	0,26	0,84	0,18	0,56	0,09	0,28
100	30	0,29	2,80	0,22	2,10	0,15	1,40	0,12	1,12	0,09	0,84	0,07	0,56	0,07	0,28
50	15	0,14	2,80	0,11	2,10	0,07	1,40	0,07	1,12	0,07	0,84	0,07	0,56	0,07	0,28



Size 7010

Ratio 1/5															
Load [daN]		20000		17500		15000		10000		7500		5000		2500	
Worm screw rotation speed ω_v [rpm]	Threaded spindle translation speed v [mm/min]	P _i [kW]	M _{tv} [daNm]	P _i [kW]	M _{tv} [daNm]	P _i [kW]	M _{tv} [daNm]	P _i [kW]	M _{tv} [daNm]	P _i [kW]	M _{tv} [daNm]	P _i [kW]	M _{tv} [daNm]	P _i [kW]	M _{tv} [daNm]
1500	3000	42,6	27,7	37,3	24,3	32,0	20,8	21,3	13,8	16,0	10,4	10,7	6,95	5,33	3,46
1000	2000	28,4	27,7	24,9	24,3	21,3	20,8	14,2	13,8	10,7	10,4	7,10	6,95	3,55	3,46
750	1500	21,3	27,7	18,7	24,3	16,0	20,8	10,7	13,8	8,00	10,4	5,33	6,95	2,66	3,46
500	1000	14,2	27,7	12,4	24,3	10,7	20,8	7,10	13,8	5,33	10,4	3,55	6,95	1,78	3,46
300	600	8,53	27,7	7,46	24,3	6,39	20,8	4,26	13,8	3,20	10,4	2,13	6,95	1,07	3,46
100	200	2,84	27,7	2,49	24,3	2,13	20,8	1,42	13,8	1,07	10,4	0,71	6,95	0,36	3,46
50	100	1,42	27,7	1,24	24,3	1,07	20,8	0,71	13,8	0,53	10,4	0,36	6,95	0,18	3,46

Ratio 1/10															
Load [daN]		20000		17500		15000		10000		7500		5000		2500	
Worm screw rotation speed ω_v [rpm]	Threaded spindle translation speed v [mm/min]	P _i [kW]	M _{tv} [daNm]	P _i [kW]	M _{tv} [daNm]	P _i [kW]	M _{tv} [daNm]	P _i [kW]	M _{tv} [daNm]	P _i [kW]	M _{tv} [daNm]	P _i [kW]	M _{tv} [daNm]	P _i [kW]	M _{tv} [daNm]
1500	1500	23,4	15,2	20,5	13,3	17,6	11,4	11,7	7,60	8,80	5,70	5,86	3,80	2,93	1,90
1000	1000	15,6	15,2	13,7	13,3	11,7	11,4	7,80	7,60	5,90	5,70	3,90	3,80	1,95	1,90
750	750	11,7	15,2	10,2	13,3	8,80	11,4	5,90	7,60	4,40	5,70	2,92	3,80	1,46	1,90
500	500	7,80	15,2	6,80	13,3	5,90	11,4	3,90	7,60	2,92	5,70	1,95	3,80	0,98	1,90
300	300	4,68	15,2	4,10	13,3	3,50	11,4	2,34	7,60	1,75	5,70	1,17	3,80	0,58	1,90
100	100	1,56	15,2	1,37	13,3	1,17	11,4	0,78	7,60	0,59	5,70	0,39	3,80	0,20	1,90
50	50	0,78	15,2	0,68	13,3	0,58	11,4	0,39	7,60	0,29	5,70	0,20	3,80	0,10	1,90

Ratio 1/30															
Load [daN]		20000		17500		15000		10000		7500		5000		2500	
Worm screw rotation speed ω_v [rpm]	Threaded spindle translation speed v [mm/min]	P _i [kW]	M _{tv} [daNm]	P _i [kW]	M _{tv} [daNm]	P _i [kW]	M _{tv} [daNm]	P _i [kW]	M _{tv} [daNm]	P _i [kW]	M _{tv} [daNm]	P _i [kW]	M _{tv} [daNm]	P _i [kW]	M _{tv} [daNm]
1500	500	11,7	7,60	10,3	6,70	8,80	5,70	5,90	3,80	4,50	2,90	2,90	1,90	1,46	0,95
1000	333	7,80	7,60	6,90	6,70	5,90	5,70	3,90	3,80	3,00	2,90	2,00	1,90	1,00	0,95
750	250	5,85	7,60	5,16	6,70	4,40	5,70	2,93	3,80	2,23	2,90	1,46	1,90	0,73	0,95
500	167	3,90	7,60	3,44	6,70	2,92	5,70	1,95	3,80	1,49	2,90	0,98	1,90	0,49	0,95
300	100	2,34	7,60	2,06	6,70	1,76	5,70	1,17	3,80	0,89	2,90	0,58	1,90	0,29	0,95
100	33	0,78	7,60	0,69	6,70	0,59	5,70	0,39	3,80	0,30	2,90	0,20	1,90	0,10	0,95
50	16,7	0,39	7,60	0,34	6,70	0,30	5,70	0,20	3,80	0,14	2,90	0,10	1,90	0,07	0,95

Size 8010

Ratio 1/5															
Load [daN]		25000		20000		15000		10000		7500		5000		2500	
Worm screw rotation speed ω_v [rpm]	Threaded spindle translation speed v [mm/min]	P _i	M _{tv}	P _i	M _{tv}	P _i	M _{tv}	P _i	M _{tv}	P _i	M _{tv}	P _i	M _{tv}	P _i	M _{tv}
		[kW]	[daNm]	[kW]	[daNm]	[kW]	[daNm]	[kW]	[daNm]	[kW]	[daNm]	[kW]	[daNm]	[kW]	[daNm]
1500	3000	55,7	36,2	44,6	29,0	33,4	21,7	22,3	14,5	16,7	10,9	11,2	7,24	5,57	3,62
1000	2000	37,2	36,2	29,7	29,0	22,3	21,7	14,9	14,5	11,2	10,9	7,43	7,24	3,72	3,62
750	1500	27,9	36,2	22,3	29,0	16,7	21,7	11,2	14,5	6,68	10,9	5,57	7,24	2,79	3,62
500	1000	18,6	36,2	14,9	29,0	11,2	21,7	7,43	14,5	5,57	10,9	3,72	7,24	1,86	3,62
300	600	11,2	36,2	8,92	29,0	6,68	21,7	4,46	14,5	3,34	10,9	2,23	7,24	1,12	3,62
100	200	3,72	36,2	2,97	29,0	2,23	21,7	1,49	14,5	1,12	10,9	0,75	7,24	0,38	3,62
50	100	1,86	36,2	1,49	29,0	1,12	21,7	0,75	14,5	0,56	10,9	0,38	7,24	0,19	3,62

Ratio 1/10															
Load [daN]		25000		20000		15000		10000		7500		5000		2500	
Worm screw rotation speed ω_v [rpm]	Threaded spindle translation speed v [mm/min]	P _i	M _{tv}	P _i	M _{tv}	P _i	M _{tv}	P _i	M _{tv}	P _i	M _{tv}	P _i	M _{tv}	P _i	M _{tv}
		[kW]	[daNm]	[kW]	[daNm]	[kW]	[daNm]	[kW]	[daNm]	[kW]	[daNm]	[kW]	[daNm]	[kW]	[daNm]
1500	1500	30,8	20,0	24,5	16,0	18,4	12,0	12,3	8,00	9,20	6,00	6,20	4,00	3,10	2,00
1000	1000	20,5	20,0	16,4	16,0	12,3	12,0	8,20	8,00	6,02	6,00	4,10	4,00	2,05	2,00
750	750	15,4	20,0	12,3	16,0	9,24	12,0	6,16	8,00	4,62	6,00	3,08	4,00	1,54	2,00
500	500	10,3	20,0	8,20	16,0	6,16	12,0	4,10	8,00	3,08	6,00	2,05	4,00	1,03	2,00
300	300	6,16	20,0	4,90	16,0	3,70	12,0	2,50	8,00	1,85	6,00	1,23	4,00	0,62	2,00
100	100	2,06	20,0	1,65	16,0	1,24	12,0	0,82	8,00	0,62	6,00	0,41	4,00	0,21	2,00
50	50	1,02	20,0	0,82	16,0	0,61	12,0	0,41	8,00	0,31	6,00	0,21	4,00	0,11	2,00

Ratio 1/30															
Load [daN]		25000		20000		15000		10000		7500		5000		2500	
Worm screw rotation speed ω_v [rpm]	Threaded spindle translation speed v [mm/min]	P _i	M _{tv}	P _i	M _{tv}	P _i	M _{tv}	P _i	M _{tv}	P _i	M _{tv}	P _i	M _{tv}	P _i	M _{tv}
		[kW]	[daNm]	[kW]	[daNm]	[kW]	[daNm]	[kW]	[daNm]	[kW]	[daNm]	[kW]	[daNm]	[kW]	[daNm]
1500	500	14,5	9,40	11,7	7,60	8,80	5,70	5,90	3,80	4,50	2,90	2,90	1,90	1,46	0,95
1000	333	9,70	9,40	7,80	7,60	5,90	5,70	3,90	3,80	3,00	2,90	2,00	1,90	1,00	0,95
750	250	7,30	9,40	5,85	7,60	4,40	5,70	2,93	3,80	2,23	2,90	1,46	1,90	0,73	0,95
500	167	4,80	9,40	3,90	7,60	2,92	5,70	1,95	3,80	1,49	2,90	0,98	1,90	0,49	0,95
300	100	2,90	9,40	2,34	7,60	1,76	5,70	1,17	3,80	0,89	2,90	0,58	1,90	0,29	0,95
100	33	0,96	9,40	0,78	7,60	0,59	5,70	0,39	3,80	0,30	2,90	0,20	1,90	0,10	0,95
50	16,7	0,48	9,40	0,39	7,60	0,30	5,70	0,20	3,80	0,14	2,90	0,10	1,90	0,07	0,95



Size 9010

Ratio 1/10													
Load [daN]		35000		25000		20000		15000		10000		5000	
Worm screw rotation speed ω_v [rpm]	Threaded spindle translation speed v [mm/min]	P_i [kW]	M_{tv} [daNm]	P_i [kW]	M_{tv} [daNm]	P_i [kW]	M_{tv} [daNm]	P_i [kW]	M_{tv} [daNm]	P_i [kW]	M_{tv} [daNm]	P_i [kW]	M_{tv} [daNm]
1500	1800	57,2	37,2	40,8	26,5	32,7	21,2	24,5	15,9	16,4	10,6	8,20	5,30
1000	1200	38,2	37,2	27,2	26,5	21,8	21,2	16,4	15,9	10,9	10,6	5,50	5,30
750	900	28,6	37,2	20,4	26,5	16,4	21,2	12,3	15,9	8,20	10,6	4,10	5,30
500	600	19,1	37,2	13,6	26,5	10,9	21,2	8,20	15,9	5,50	10,6	2,80	5,30
300	360	11,5	37,2	8,20	26,5	6,60	21,2	4,90	15,9	3,30	10,6	1,70	5,30
100	120	3,90	37,2	2,80	26,5	2,20	21,2	1,70	15,9	1,10	10,6	0,60	5,30
50	60	1,90	37,2	1,40	26,5	1,10	21,2	0,90	15,9	0,60	10,6	0,30	5,30

Ratio 1/30													
Load [daN]		35000		25000		20000		15000		10000		5000	
Worm screw rotation speed ω_v [rpm]	Threaded spindle translation speed v [mm/min]	P_i [kW]	M_{tv} [daNm]	P_i [kW]	M_{tv} [daNm]	P_i [kW]	M_{tv} [daNm]	P_i [kW]	M_{tv} [daNm]	P_i [kW]	M_{tv} [daNm]	P_i [kW]	M_{tv} [daNm]
1500	600	28,6	18,6	20,4	13,3	16,4	10,7	12,3	8,00	8,20	5,40	4,10	2,70
1000	400	19,1	18,6	13,6	13,3	10,9	10,7	8,20	8,00	5,50	5,40	2,80	2,70
750	300	14,3	18,6	10,2	13,3	8,20	10,7	6,20	8,00	4,10	5,40	2,10	2,70
500	200	9,60	18,6	6,90	13,3	5,50	10,7	4,10	8,00	2,80	5,40	1,40	2,70
300	120	5,80	18,6	4,10	13,3	3,30	10,7	2,50	8,00	1,70	5,40	0,90	2,70
100	40	1,90	18,6	1,40	13,3	1,10	10,7	0,90	8,00	0,60	5,40	0,30	2,70
50	20	1,00	18,6	0,70	13,3	0,60	10,7	0,50	8,00	0,30	5,40	0,20	2,70

Size 10012

Ratio 1/10															
Load [daN]		40000		30000		25000		20000		15000		10000		5000	
Worm screw rotation speed ω_v [rpm]	Threaded spindle translation speed v [mm/min]	P_i [kW]	M_{tv} [daNm]	P_i [kW]	M_{tv} [daNm]	P_i [kW]	M_{tv} [daNm]	P_i [kW]	M_{tv} [daNm]	P_i [kW]	M_{tv} [daNm]	P_i [kW]	M_{tv} [daNm]	P_i [kW]	M_{tv} [daNm]
1500	1800	65,4	42,5	49,0	31,8	40,8	26,5	32,7	21,2	24,5	15,9	16,4	10,6	8,16	5,30
1000	1200	43,6	42,5	32,7	31,8	27,2	26,5	21,8	21,2	16,4	15,9	10,9	10,6	5,45	5,30
750	900	32,7	42,5	24,5	31,8	20,4	26,5	16,4	21,2	12,3	15,9	8,16	10,6	4,08	5,30
500	600	21,8	42,5	16,4	31,8	13,6	26,5	10,9	21,2	8,16	15,9	5,45	10,6	2,73	5,30
300	360	13,1	42,5	9,80	31,8	8,17	26,5	6,54	21,2	4,90	15,9	3,27	10,6	1,64	5,30
100	120	4,36	42,5	3,27	31,8	2,72	26,5	2,18	21,2	1,64	15,9	1,09	10,6	0,55	5,30
50	60	2,18	42,5	1,64	31,8	1,36	26,5	1,09	21,2	0,82	15,9	0,55	10,6	0,28	5,30

Ratio 1/30															
Load [daN]		40000		30000		25000		20000		15000		10000		5000	
Worm screw rotation speed ω_v [rpm]	Threaded spindle translation speed v [mm/min]	P_i [kW]	M_{tv} [daNm]	P_i [kW]	M_{tv} [daNm]	P_i [kW]	M_{tv} [daNm]	P_i [kW]	M_{tv} [daNm]	P_i [kW]	M_{tv} [daNm]	P_i [kW]	M_{tv} [daNm]	P_i [kW]	M_{tv} [daNm]
1500	600	32,7	21,3	24,5	15,9	20,4	13,3	16,4	10,7	12,3	7,99	8,17	5,32	4,09	2,66
1000	400	21,8	21,3	16,4	15,9	13,6	13,3	10,9	10,7	8,17	7,99	5,45	5,32	2,72	2,66
750	300	16,4	21,3	12,3	15,9	10,2	13,3	8,17	10,7	6,13	7,99	4,09	5,32	2,05	2,66
500	200	10,9	21,3	8,17	15,9	6,81	13,3	5,45	10,7	4,09	7,99	2,72	5,32	1,36	2,66
300	120	6,54	21,3	4,90	15,9	4,08	13,3	3,27	10,7	2,45	7,99	1,64	5,32	0,82	2,66
100	40	2,18	21,3	1,64	15,9	1,36	13,3	1,09	10,7	0,82	7,99	0,55	5,32	0,28	2,66
50	20	1,09	21,3	0,82	15,9	0,68	13,3	0,55	10,7	0,41	7,99	0,28	5,32	0,14	2,66



Size 12014

Ratio 1/10															
Load [daN]		60000		50000		40000		30000		20000		15000		10000	
Worm screw rotation speed ω_v [rpm]	Threaded spindle translation speed v [mm/min]	P _i [kW]	M _{tv} [daNm]	P _i [kW]	M _{tv} [daNm]	P _i [kW]	M _{tv} [daNm]	P _i [kW]	M _{tv} [daNm]	P _i [kW]	M _{tv} [daNm]	P _i [kW]	M _{tv} [daNm]	P _i [kW]	M _{tv} [daNm]
1500	2100	121	78,6	101	65,6	80,7	52,4	60,6	39,3	40,4	26,2	30,3	19,7	20,2	13,1
1000	1400	80,7	78,6	67,3	65,6	53,8	52,4	40,4	39,3	26,9	26,2	20,2	19,7	13,5	13,1
750	1050	60,1	78,6	50,5	65,6	40,4	52,4	30,3	39,3	20,2	26,2	15,2	19,7	10,1	13,1
500	700	40,3	78,6	33,6	65,6	26,9	52,4	20,2	39,3	13,5	26,2	10,1	19,7	6,73	13,1
300	420	24,2	78,6	20,2	65,6	16,1	52,4	12,1	39,3	8,07	26,2	6,06	19,7	4,04	13,1
100	140	8,07	78,6	6,73	65,6	5,38	52,4	4,04	39,3	2,69	26,2	2,02	19,7	1,35	13,1
50	70	4,04	78,6	3,36	65,6	2,69	52,4	2,02	39,3	1,35	26,2	1,01	19,7	0,67	13,1

Ratio 1/30															
Load [daN]		60000		50000		40000		30000		20000		15000		10000	
Worm screw rotation speed ω_v [rpm]	Threaded spindle translation speed v [mm/min]	P _i [kW]	M _{tv} [daNm]	P _i [kW]	M _{tv} [daNm]	P _i [kW]	M _{tv} [daNm]	P _i [kW]	M _{tv} [daNm]	P _i [kW]	M _{tv} [daNm]	P _i [kW]	M _{tv} [daNm]	P _i [kW]	M _{tv} [daNm]
1500	700	62,5	40,5	52,0	33,8	41,6	27,0	31,2	20,3	20,8	13,5	15,6	10,2	10,4	6,75
1000	466	41,5	40,5	34,6	33,8	27,7	27,0	20,8	20,3	13,9	13,5	10,4	10,2	6,92	6,75
750	350	31,2	40,5	26,0	33,8	20,8	27,0	15,6	20,3	10,4	13,5	7,80	10,2	5,20	6,75
500	233	20,8	40,5	17,3	33,8	13,8	27,0	10,4	20,3	6,92	13,5	5,20	10,2	3,46	6,75
300	140	12,5	40,5	10,4	33,8	8,32	27,0	6,24	20,3	4,16	13,5	3,12	10,2	2,08	6,75
100	46	4,10	40,5	3,42	33,8	2,73	27,0	2,05	20,3	1,37	13,5	1,03	10,2	0,68	6,75
50	23	2,05	40,5	1,71	33,8	1,37	27,0	1,03	20,3	0,69	13,5	0,52	10,2	0,34	6,75

Size 14014

Ratio 1/12															
Load [daN]		80000		60000		40000		30000		20000		10000		5000	
Worm screw rotation speed ω_v [rpm]	Threaded spindle translation speed v [mm/min]	P _i	M _{tv}	P _i	M _{tv}	P _i	M _{tv}	P _i	M _{tv}	P _i	M _{tv}	P _i	M _{tv}	P _i	M _{tv}
		[kW]	[daNm]	[kW]	[daNm]	[kW]	[daNm]	[kW]	[daNm]	[kW]	[daNm]	[kW]	[daNm]	[kW]	[daNm]
1500	1750	143	92,9	107	69,6	71,5	46,5	53,6	34,8	35,8	23,3	17,9	11,7	8,94	5,81
1000	1166	95,3	92,9	71,5	69,6	47,6	46,5	35,7	34,8	23,9	23,3	11,9	11,7	5,96	5,81
750	875	71,5	92,9	53,6	69,6	35,8	46,5	26,8	34,8	17,9	23,3	8,94	11,7	4,47	5,81
500	583	47,6	92,9	35,7	69,6	23,8	46,5	17,9	34,8	11,9	23,3	5,96	11,7	2,98	5,81
300	350	28,6	92,9	21,5	69,6	14,3	46,5	10,8	34,8	7,15	23,3	3,58	11,7	1,79	5,81
100	116	9,48	92,9	7,11	69,6	4,74	46,5	3,56	34,8	2,37	23,3	1,19	11,7	0,60	5,81
50	58	4,73	92,9	3,56	69,6	2,37	46,5	1,78	34,8	1,19	23,3	0,60	11,7	0,30	5,81

Ratio 1/36															
Load [daN]		80000		60000		40000		30000		20000		10000		5000	
Worm screw rotation speed ω_v [rpm]	Threaded spindle translation speed v [mm/min]	P _i	M _{tv}	P _i	M _{tv}	P _i	M _{tv}	P _i	M _{tv}	P _i	M _{tv}	P _i	M _{tv}	P _i	M _{tv}
		[kW]	[daNm]	[kW]	[daNm]	[kW]	[daNm]	[kW]	[daNm]	[kW]	[daNm]	[kW]	[daNm]	[kW]	[daNm]
1500	583	76,1	49,4	57,1	37,1	38,1	24,8	28,6	18,6	19,1	12,4	9,51	6,18	4,76	3,10
1000	388	50,6	49,4	38,0	37,1	25,3	24,8	19,0	18,6	12,7	12,4	6,33	6,18	3,17	3,10
750	291	38,1	49,4	28,6	37,1	19,1	24,8	14,3	18,6	9,51	12,4	4,76	6,18	2,38	3,10
500	194	25,4	49,4	19,1	37,1	12,7	24,8	9,51	18,6	6,34	12,4	3,17	6,18	1,59	3,10
300	116	15,2	49,4	11,4	37,1	7,59	24,8	5,69	18,6	3,80	12,4	1,90	6,18	0,95	3,10
100	38	4,97	49,4	3,73	37,1	2,49	24,8	1,87	18,6	1,25	12,4	0,63	6,18	0,32	3,10
50	19	2,49	49,4	1,87	37,1	1,25	24,8	0,94	18,6	0,63	12,4	0,32	6,18	0,16	3,10



Size 16016

Ratio 1/12															
Load [daN]		100000		80000		60000		40000		30000		20000		10000	
Worm screw rotation speed ω_v [rpm]	Threaded spindle translation speed v [mm/min]	P_i [kW]	M_{tv} [daNm]	P_i [kW]	M_{tv} [daNm]	P_i [kW]	M_{tv} [daNm]	P_i [kW]	M_{tv} [daNm]	P_i [kW]	M_{tv} [daNm]	P_i [kW]	M_{tv} [daNm]	P_i [kW]	M_{tv} [daNm]
1500	2000	218	141	174	113	131	85,0	87,0	56,5	65,0	42,5	43,6	28,3	21,8	14,2
1000	1333	145	141	116	113	87,0	85,0	58,0	56,5	43,6	42,5	29,0	28,3	14,5	14,2
750	1000	109	141	87,0	113	65,4	85,0	43,6	56,5	32,7	42,5	21,8	28,3	10,9	14,2
500	667	72,6	141	58,1	113	43,6	85,0	29,0	56,5	21,8	42,5	14,5	28,3	7,26	14,2
300	400	43,6	141	34,9	113	26,1	85,0	17,4	56,5	13,1	42,5	8,71	28,3	4,36	14,2
100	133	14,5	141	11,6	113	8,71	85,0	5,81	56,5	4,36	42,5	2,90	28,3	1,45	14,2
50	66,6	7,26	141	5,81	113	4,36	85,0	2,90	56,5	2,18	42,5	1,45	28,3	0,73	14,2

Ratio 1/36															
Load [daN]		100000		80000		60000		40000		30000		20000		10000	
Worm screw rotation speed ω_v [rpm]	Threaded spindle translation speed v [mm/min]	P_i [kW]	M_{tv} [daNm]	P_i [kW]	M_{tv} [daNm]	P_i [kW]	M_{tv} [daNm]	P_i [kW]	M_{tv} [daNm]	P_i [kW]	M_{tv} [daNm]	P_i [kW]	M_{tv} [daNm]	P_i [kW]	M_{tv} [daNm]
1500	666	121	78,6	96,8	62,8	72,6	47,2	48,4	31,5	36,3	23,6	24,2	15,7	12,1	7,86
1000	444	80,7	78,6	64,5	62,8	48,4	47,2	32,3	31,5	24,2	23,6	16,1	15,7	8,07	7,86
750	333	60,5	78,6	48,5	62,8	36,3	47,2	24,2	31,5	18,2	23,6	12,1	15,7	6,05	7,86
500	222	40,4	78,6	32,3	62,8	24,2	47,2	16,1	31,5	12,1	23,6	8,07	15,7	4,03	7,86
300	133	24,2	78,6	19,4	62,8	14,5	47,2	9,68	31,5	7,26	23,6	4,84	15,7	2,42	7,86
100	44	8,06	78,6	6,45	62,8	4,84	47,2	3,22	31,5	2,42	23,6	1,61	15,7	0,81	7,86
50	22	4,03	78,6	3,22	62,8	2,42	47,2	1,61	31,5	1,21	23,6	0,81	15,7	0,41	7,86

Size 20018

Ratio 1/12															
Load [daN]		150000		130000		100000		80000		50000		25000		10000	
Worm screw rotation speed ω_v [rpm]	Threaded spindle translation speed v [mm/min]	P _i	M _{tv}	P _i	M _{tv}	P _i	M _{tv}	P _i	M _{tv}	P _i	M _{tv}	P _i	M _{tv}	P _i	M _{tv}
		[kW]	[daNm]	[kW]	[daNm]	[kW]	[daNm]	[kW]	[daNm]	[kW]	[daNm]	[kW]	[daNm]	[kW]	[daNm]
1500	2250	350	239	284	197	219	149	175	119	110	74,4	54,5	37,2	21,8	14,9
1000	1500	237	239	192	197	148	149	119	119	73,9	74,4	36,9	37,2	14,7	14,9
750	1125	179	239	146	197	112	149	89,4	119	55,8	74,4	27,9	37,2	11,1	14,9
500	750	122	239	98,9	197	75,9	149	60,7	119	37,9	74,4	18,9	37,2	7,60	14,9
300	450	75,0	239	60,4	197	46,4	149	37,1	119	23,2	74,4	11,6	37,2	4,64	14,9
100	150	26,8	239	21,8	197	16,7	149	13,3	119	8,37	74,4	4,18	37,2	1,67	14,9
50	75	13,8	239	11,2	197	8,63	149	6,90	119	4,31	74,4	2,16	37,2	0,86	14,9

Ratio 1/36															
Load [daN]		150000		130000		100000		80000		50000		25000		10000	
Worm screw rotation speed ω_v [rpm]	Threaded spindle translation speed v [mm/min]	P _i	M _{tv}	P _i	M _{tv}	P _i	M _{tv}	P _i	M _{tv}	P _i	M _{tv}	P _i	M _{tv}	P _i	M _{tv}
		[kW]	[daNm]	[kW]	[daNm]	[kW]	[daNm]	[kW]	[daNm]	[kW]	[daNm]	[kW]	[daNm]	[kW]	[daNm]
1500	750	187	94,9	109	83,2	83,4	64,1	66,7	50,7	41,7	31,7	20,9	15,9	8,33	6,36
1000	500	124	94,9	74,3	83,2	57,2	64,1	47,7	50,7	28,6	31,7	14,3	15,9	5,71	6,36
750	375	93,6	94,9	57,9	83,2	44,5	64,1	35,6	50,7	22,3	31,7	11,2	15,9	4,45	6,36
500	250	63,0	94,9	39,8	83,2	30,6	64,1	24,5	50,7	15,3	31,7	7,65	15,9	3,06	6,36
300	150	37,4	94,9	25,6	83,2	19,7	64,1	15,8	50,7	9,85	31,7	4,92	15,9	1,97	6,36
100	50	11,9	94,9	10,4	83,2	7,95	64,1	6,36	50,7	3,98	31,7	2,00	15,9	0,85	6,36
50	25	6,40	94,9	5,55	83,2	4,26	64,1	3,41	50,7	2,13	31,7	1,06	15,9	0,65	6,36



Size 25022

Ratio 1/12															
Load [daN]		200000		180000		150000		130000		100000		80000		50000	
Worm screw rotation speed ω_v [rpm]	Threaded spindle translation speed v [mm/min]	P_i [kW]	M_{tv} [daNm]	P_i [kW]	M_{tv} [daNm]	P_i [kW]	M_{tv} [daNm]	P_i [kW]	M_{tv} [daNm]	P_i [kW]	M_{tv} [daNm]	P_i [kW]	M_{tv} [daNm]	P_i [kW]	M_{tv} [daNm]
1500	2750	543	370	489	332	407	276	353	240	271	185	217	148	135	92,2
1000	1833	368	370	331	332	276	276	240	240	184	185	147	148	92,0	92,2
750	1375	278	370	250	332	208	276	180	240	139	185	111	148	69,5	92,2
500	916	189	370	170	332	141	276	122	240	94,2	185	75,6	148	47,2	92,2
300	550	115	370	104	332	86,4	276	75,1	240	57,8	185	46,2	148	28,8	92,2
100	183	41,7	370	37,5	332	31,2	276	27,1	240	20,8	185	16,6	148	10,4	92,2
50	92	21,4	370	19,3	332	16,1	276	13,9	240	10,7	185	8,59	148	5,37	92,2

Ratio 1/36															
Load [daN]		200000		180000		150000		130000		100000		80000		50000	
Worm screw rotation speed ω_v [rpm]	Threaded spindle translation speed v [mm/min]	P_i [kW]	M_{tv} [daNm]	P_i [kW]	M_{tv} [daNm]	P_i [kW]	M_{tv} [daNm]	P_i [kW]	M_{tv} [daNm]	P_i [kW]	M_{tv} [daNm]	P_i [kW]	M_{tv} [daNm]	P_i [kW]	M_{tv} [daNm]
1500	916	207	157	186	141	155	117	134	101	103	78,0	82,9	62,8	51,8	39,1
1000	611	142	157	128	141	106	117	92,4	101	71,1	78,0	56,8	62,8	35,5	39,1
750	458	110	157	99,6	141	83,0	117	72,0	101	55,3	78,0	44,3	62,8	27,6	39,1
500	305	76,2	157	68,5	141	57,1	117	49,5	101	38,1	78,0	30,4	62,8	19,0	39,1
300	183	49,0	157	44,1	141	36,7	117	31,8	101	24,5	78,0	19,6	62,8	12,2	39,1
100	61	19,7	157	17,8	141	14,8	117	12,8	101	9,90	78,0	7,92	62,8	4,95	39,1
50	30	10,6	157	9,54	141	7,95	117	6,89	101	5,30	78,0	4,24	62,8	2,65	39,1

Series construction models



B model



S model



D model

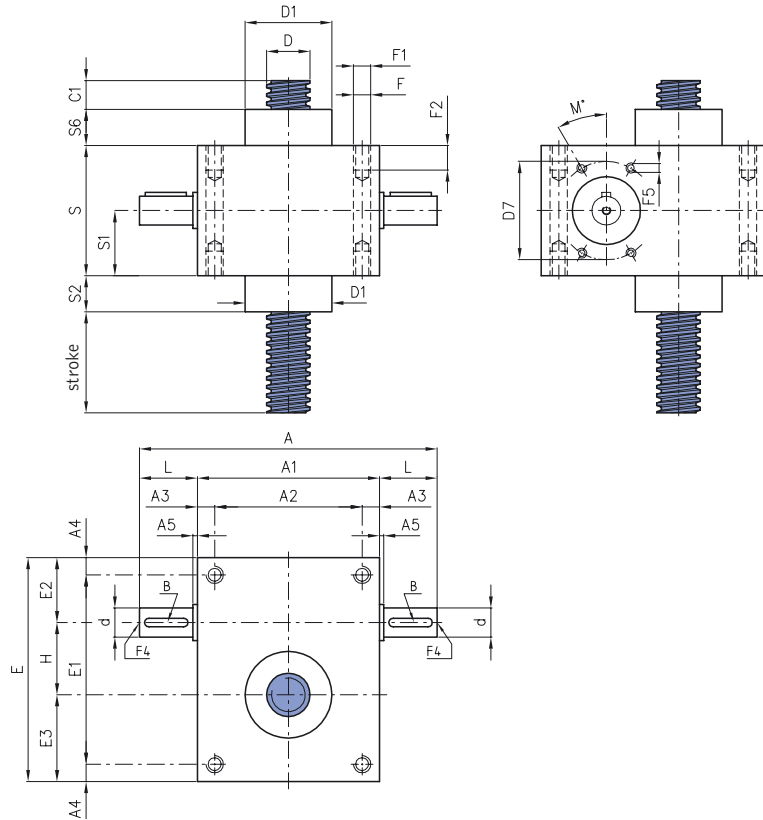

TP Models								
XTP Models*								
Size	183	204	306	407	559	7010	8010	9010
A	118	150	206	270	270	350	350	390
A1	70	100	126	160	170	230	230	250
A2	56	80	102	130	134	180	180	200
A3	7	10	12	15	18	25	25	25
A4	7	7,5	12	15	18	25	25	25
A5	4	-	-	-	-	-	-	-
B	3x3x15	4x4x20	6x6x30	8x7x40	8x7x40	8x7x50	8x7x50	12x8x60
C1	15	15	20	25	25	25	25	40
d Ø j6	9	12	20	25	25	30	30	40
D Ø	18x3	20x4	30x6	40x7	55x9	70x10	80x10	100x12
D1 Ø $\frac{-0,2}{-0,3}$	30	44	60	69	90	120	120	150
D7 Ø	-	60	68	86	86	74	74	100
E	94	100	155	195	211	280	280	320
E1	80	85	131	165	175	230	230	270
E2	29	32,5	45	50	63	75	75	85
E3	35	37,5	60	75	78	115	115	125
F Ø	9	9	11	13	-	-	-	-
F1	-	-	-	-	M20	M30	M30	M30
F2	-	-	-	-	30	45	45	45
F4	-	M5x10	M6x12	M8x15	M8x15	M10x18	M10x18	M10x18
F5 (n° of holes)	-	M5x12(4)	M6x12(4)	M8X16(4)	M8X16(4)	M8x15(6)	M8x15(6)	M10x18(4)
H	30	30	50	70	70	90	90	110
L	24	25	40	55	50	60	60	70
M [°]	-	30	45	30	30	30	30	45
S	50	70	90	120	150	176	176	230
S1	25	35	45	60	75	88	88	115
S2	10	20	25	35	40	40	40	50
S6	10	20	25	35	40	40	40	50

* XTP Model: stainless steel version



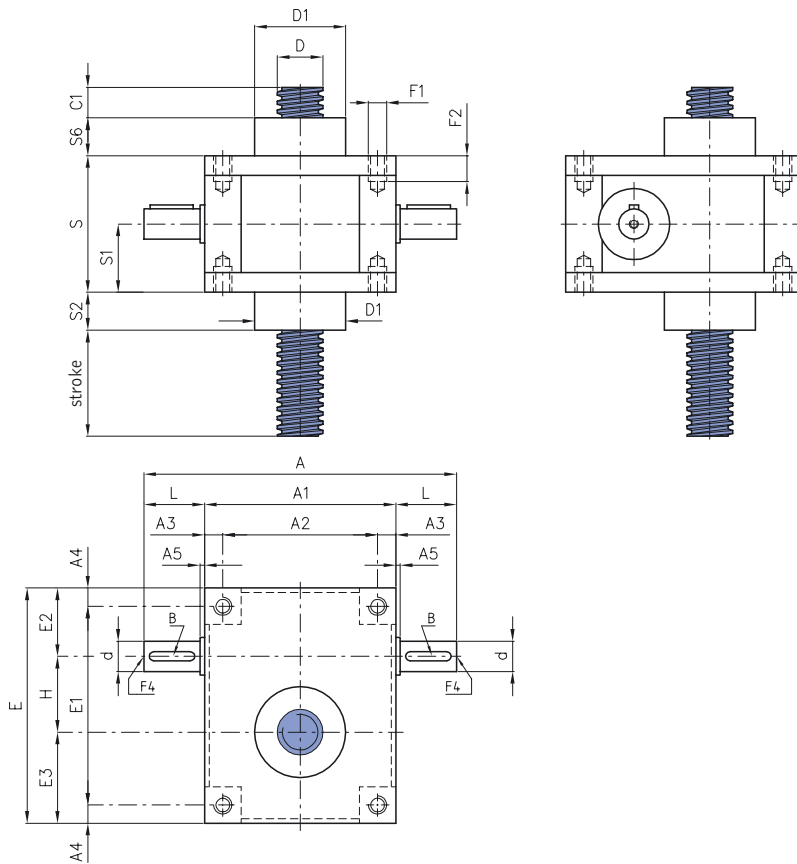

Series construction models



B model



S model



D model

Extra heavy TP models

Size	10012	12014	14014	16016	20018	25022
A	490	490	780	780	920	920
A1	320	320	500	500	600	600
A2	230	230	360	360	470	470
A3	45	45	70	70	65	65
A4	25	25	40	40	60	60
A5	5	5	10	10	20	20
B	16x10x70	16x10x70	20x12x110	20x12x110	28x16x120	28x16x120
C1	40	40	50	50	50	50
d Ø j6	55	55	70	70	100	100
D Ø	100x12	120x14	140x14	160x16	200x18	250x22
D1 Ø $_{-0.2}^{+0.3}$	210	210	300	300	370	370
E	405	405	590	590	780	780
E1	355	355	510	510	660	660
E2	105	105	160	160	220	220
E3	160	160	230	230	310	310
F1	M30	M30	M56	M56	M64	M64
F2	45	45	110	110	130	130
F4	M12x25	M12x25	M14x30	M14x30	M16x35	M16x35
H	140	140	200	200	250	250
L	85	85	140	140	160	160
S	270	270	370	370	480	480
S1	135	135	185	185	240	240
S2	50	50	60	60	60	60
S6	50	50	60	60	60	60

Series construction models



B form



S form



D form

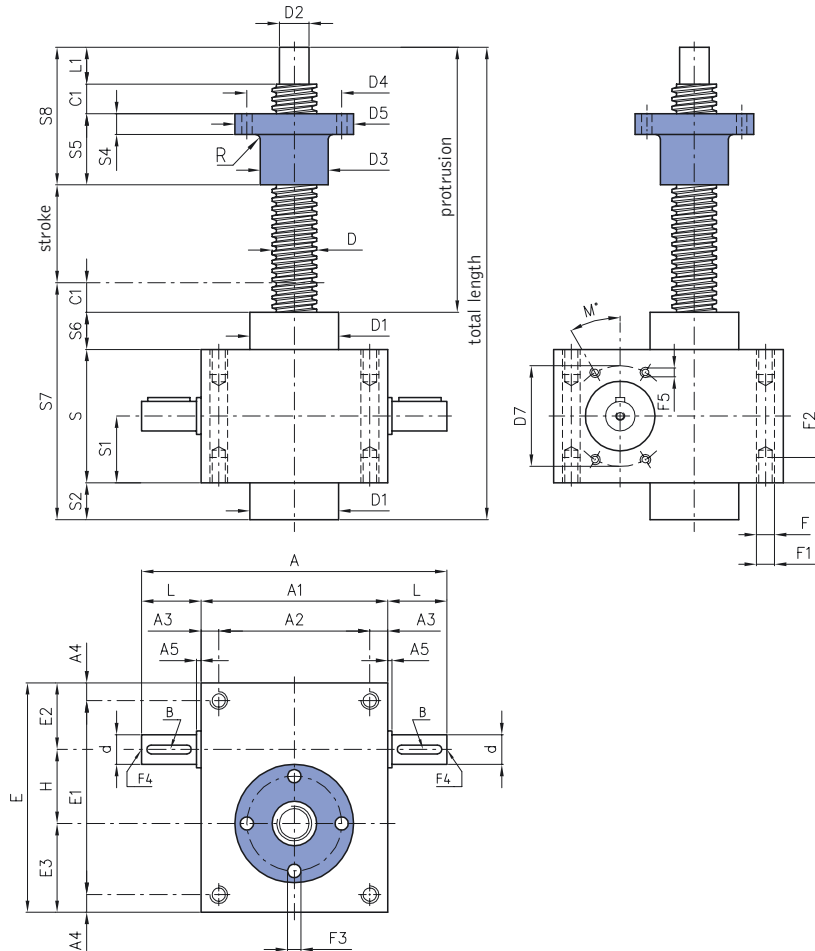

TPR models								
XTPR Models*								
Size	183	204	306	407	559	7010	8010	9010
A	118	150	206	270	270	350	350	390
A1	70	100	126	160	170	230	230	250
A2	56	80	102	130	134	180	180	200
A3	7	10	12	15	18	25	25	25
A4	7	7,5	12	15	18	25	25	25
A5	4	-	-	-	-	-	-	-
B	3x3x15	4x4x20	6x6x30	8x7x40	8x7x40	8x7x50	8x7x50	12x8x60
C1	15	15	20	25	25	25	25	40
d Ø j6	9	12	20	25	25	30	30	40
D Ø	18x3	20x4	30x6	40x7	55x9	70x10	80x10	100x12
D1 Ø ^{-0,2} / _{-0,3}	30	44	60	69	90	120	120	150
D2 Ø k6	12	15	20	25	40	55	60	70
D3 Ø	26	32	46	60	76	100	110	150
D4 Ø	40	45	64	78	100	140	150	190
D5 Ø	54	60	80	96	130	180	190	230
D7 Ø	-	60	68	86	86	74	74	100
E	94	100	155	195	211	280	280	320
E1	80	85	131	165	175	230	230	270
E2	29	32,5	45	50	63	75	75	85
E3	35	37,5	60	75	78	115	115	125
F Ø	9	9	11	13	-	-	-	-
F1	-	-	-	-	M20	M30	M30	M30
F2	-	-	-	-	30	45	45	45
F3 (4 holes)	7	7	7	9	13	18	18	20
F4	-	M5x10	M6x12	M8x15	M8x15	M10x18	M10x18	M10x18
F5 (n° holes)	-	M5x12 (4)	M6x12 (4)	M8x16 (4)	M8x16 (4)	M8x15 (6)	M8x15 (6)	M10x18 (4)
H	30	30	50	70	70	90	90	110
L	24	25	40	55	50	60	60	70
L1	14	20	25	30	45	70	75	80
M [°]	-	30	45	30	30	30	30	45
R (radius)	3	3	3	3	3	3	3	3
S	50	70	90	120	150	176	176	230
S1	25	35	45	60	75	88	88	115
S2	10	20	25	35	40	40	40	50
S4	12	12	14	16	20	30	30	45
S5	45	45	48	75	100	105	110	135
S6	10	20	25	35	40	40	40	50
S7	85	125	160	215	255	281	281	370
S8	74	80	93	130	170	200	210	255

* XTPR Models: stainless steel version



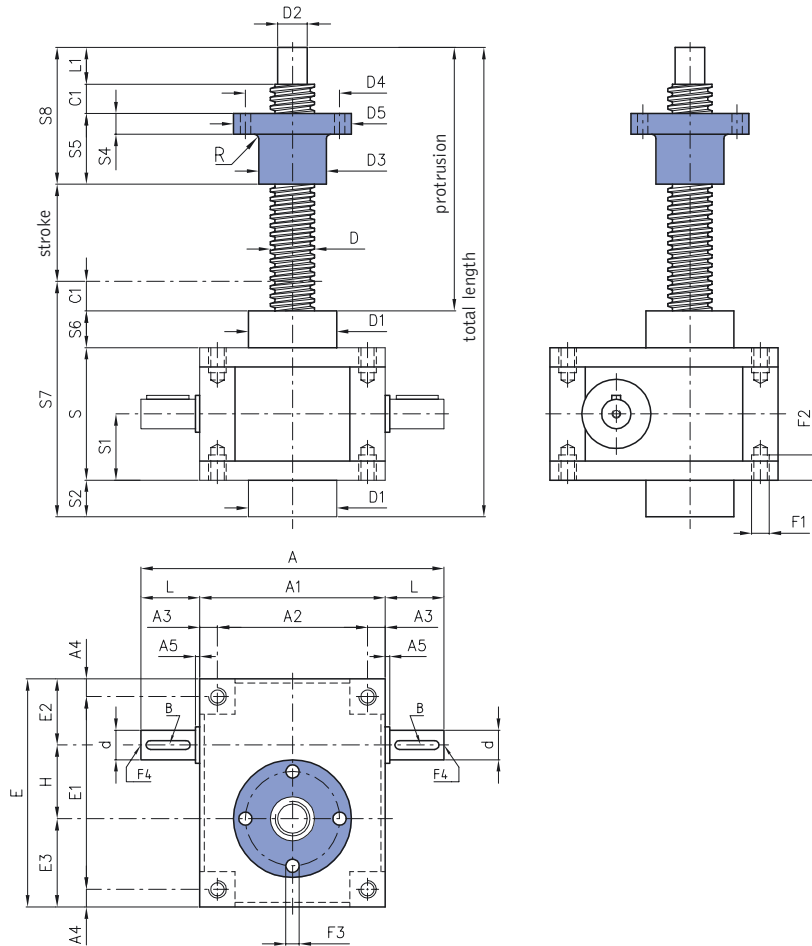

Series construction models



B model



S model



D model

Extra heavy TPR Models

Size	10012	12014	14014	16016	20018	25022
A	490	490	780	780	920	920
A1	320	320	500	500	600	600
A2	230	230	360	360	470	470
A3	45	45	70	70	65	65
A4	25	25	40	40	60	60
A5	5	5	10	10	20	20
B	16x10x70	16x10x70	20x12x110	20x12x110	28x16x120	28x16x120
C1	40	40	50	50	50	50
d Ø j6	55	55	70	70	100	100
D Ø	100x12	120x14	140x14	160x16	200x18	250x22
D1 Ø $_{-0,3}^{+0,2}$	210	210	300	300	370	370
D2 Ø k6	70	90	120	130	160	200
D3 Ø	150	180	210	210	310	310
D4 Ø	190	235	270	270	400	400
D5 Ø	230	280	320	320	480	480
E	405	405	590	590	780	780
E1	355	355	510	510	660	660
E2	105	105	160	160	220	220
E3	160	160	230	230	310	310
F1	M30	M30	M56	M56	M64	M64
F2	45	45	110	110	130	130
F3 (n° holes)	20 (4)	25 (4)	25 (6)	25 (6)	45 (6)	45 (6)
F4	M12x25	M12x25	M14x30	M14x30	M16x35	M16x35
H	140	140	200	200	250	250
L	85	85	140	140	160	160
L1	80	85	120	120	160	180
R (radius)	3	3	4	4	5	5
S	270	270	370	370	480	480
S1	135	135	185	185	240	240
S2	50	50	60	60	60	60
S4	45	55	80	80	100	100
S5	135	160	250	250	300	300
S6	50	50	60	60	60	60
S7	410	410	540	540	650	650
S8	255	285	420	420	510	530

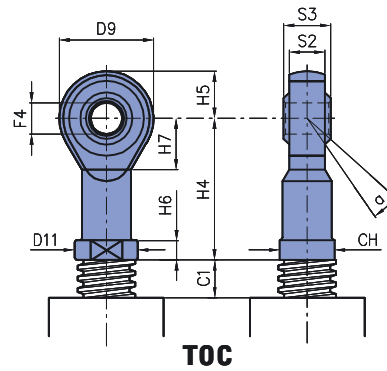
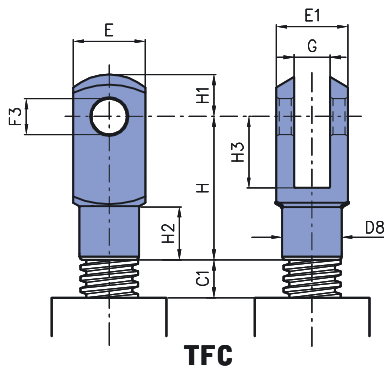
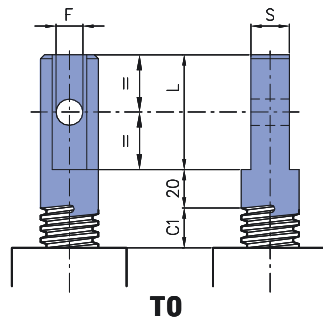
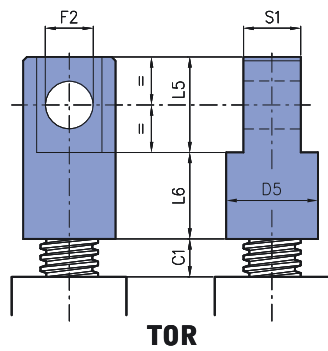

End fittings

Size	X Models*													
	183	204	306	407	559	7010	8010	9010	10012	12014	14014	16016	20018	25022
C1	15	15	20	25	25	25	25	40	40	40	50	50	50	50
CH	-	19	30	41	50	-	-	-	-	-	-	-	-	-
D5 Ø	-	38	48	68	88	108	118	138	138	168	168	216	-	-
D8 Ø	-	20	34	48	60	-	-	-	-	-	-	-	-	-
D9 Ø	-	32	50	70	80	-	-	-	-	-	-	-	-	-
D11 Ø	-	22	34	50	58	-	-	-	-	-	-	-	-	-
E	-	24	40	55	70	-	-	-	-	-	-	-	-	-
E1	-	24	40	55	70	-	-	-	-	-	-	-	-	-
F Ø H9	-	10	14	22	30	40	45	-	-	-	-	-	-	-
F2 Ø H9	-	20	25	35	50	60	65	80	80	100	140	140	-	-
F3 Ø	-	12	20	30	35	-	-	-	-	-	-	-	-	-
F4 Ø	-	12	20	30	35	-	-	-	-	-	-	-	-	-
G	-	12	20	30	35	-	-	-	-	-	-	-	-	-
H	-	48	80	110	144	-	-	-	-	-	-	-	-	-
H1	-	14	25	38	44	-	-	-	-	-	-	-	-	-
H2	-	18	30	38	40	-	-	-	-	-	-	-	-	-
H3	-	24	40	54	72	-	-	-	-	-	-	-	-	-
H4	-	50	77	110	125	-	-	-	-	-	-	-	-	-
H5	-	16	25	35	40	-	-	-	-	-	-	-	-	-
H6	-	6,5	10	15	17	-	-	-	-	-	-	-	-	-
H7	-	17	27	36	41	-	-	-	-	-	-	-	-	-
L	-	50	60	80	80	100	110	-	-	-	-	-	-	-
L5	-	40	50	70	100	120	130	160	160	200	280	280	-	-
L6	-	35	45	55	80	90	95	120	120	150	170	180	-	-
S	-	14	20	30	42	55	65	-	-	-	-	-	-	-
S1	-	25	30	40	60	75	80	100	100	120	155	155	-	-
S2	-	12	18	25	28	-	-	-	-	-	-	-	-	-
S3	-	16	25	37	43	-	-	-	-	-	-	-	-	-
α [°]	-	13	14	17	16	-	-	-	-	-	-	-	-	-

* X models: stainless steel version

Series construction models



MBD model



MBS model



MD model



MS model



MBD model



MBS model



MD model



MS model

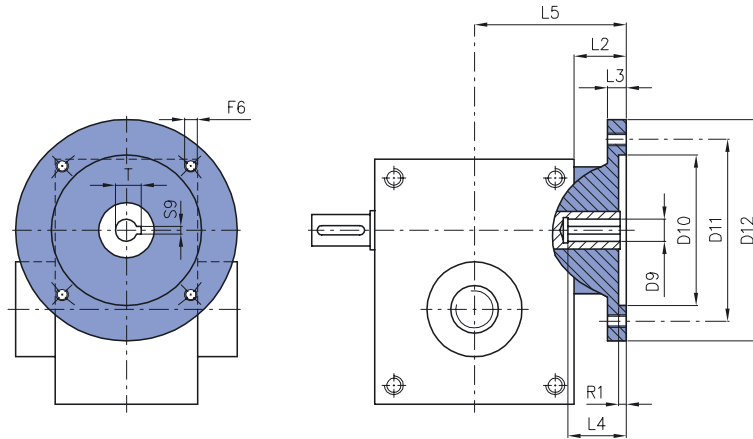

MTP-MTPR Models														
	Size	IEC Flange	D9 H7	D10 H7	D11	D12	F6	L2	L3	L4	L5	R1	S9	T
X Models*	204	56 B5	9	80	100	120	M6	30	10	20	80	4	3	10,4
		63 B5	11	95	115	140	M8	30	10	23	80	4	4	12,8
		71 B5	14	110	130	160	M8	30	10	30	80	4	5	16,3
		71 B14	14	70	85	105	7	30	10	30	80	4	5	16,3
	306	63 B5	11	95	115	140	M8	33	13	23	96	4	4	12,8
		71 B5	14	110	130	160	M8	33	13	30	96	4	5	16,3
		80 B5	19	130	165	200	M10	33	13	40	96	4	6	21,8
		80 B14	19	80	100	120	7	33	13	40	96	4	6	21,8
	407	71 B5	14	110	130	160	9	40	15	30	120	5	5	16,3
		80 B5	19	130	165	200	M10	40	15	40	120	5	6	21,8
		80 B14	19	80	100	120	7	40	15	40	120	5	6	21,8
		90 B5	24	130	165	200	M10	40	15	50	120	5	8	27,3
		90 B14	24	95	115	140	9	40	15	50	120	5	8	27,3
		100-112 B5	28	180	215	250	M12	40	15	60	120	5	8	31,3
	100-112 B14	28	110	130	160	9	40	15	60	120	5	8	31,3	
	559	71 B5	14	110	130	160	9	40	15	30	125	5	5	16,3
	80 B5	19	130	165	200	M10	40	15	40	125	5	6	21,8	
	80 B14	19	80	100	120	7	40	15	40	125	5	6	21,8	
	90 B5	24	130	165	200	M10	40	15	50	125	5	8	27,3	
	90 B14	24	95	115	140	9	40	15	50	125	5	8	27,3	
	100-112 B5	28	180	215	250	M12	40	15	60	125	5	8	31,3	
	100-112 B14	28	110	130	160	9	40	15	60	125	5	8	31,3	
7010	100-112 B5	28	180	215	250	M12	55	17	60	170	5	8	31,3	
	100-112 B14	28	110	130	160	9	55	17	60	170	5	8	31,3	
	132 B5	38	230	265	300	M12	55	17	80	170	5	10	41,3	
	132 B14	38	130	165	200	11	55	17	80	170	5	10	41,3	
8010	100-112 B5	28	180	215	250	M12	55	17	60	170	5	8	31,3	
	100-112 B14	28	110	130	160	9	55	17	60	170	5	8	31,3	
	132 B5	38	230	265	300	M12	55	17	80	170	5	10	41,3	
	132 B14	38	130	165	200	11	55	17	80	170	5	10	41,3	

* X models: stainless steel version
For non quoted dimensions see to the relative tables on pages 60-63



PR rigid protection

The application of a rigid protection in the back side of the screw jack is the ideal solution in order to prevent dust and foreign matters from coming into contact with the coupling and causing damages to the threaded spindle. The PR protection can only be applied to TP models. The overall sizes are shown in the following table.

Incompatibility: TPR models

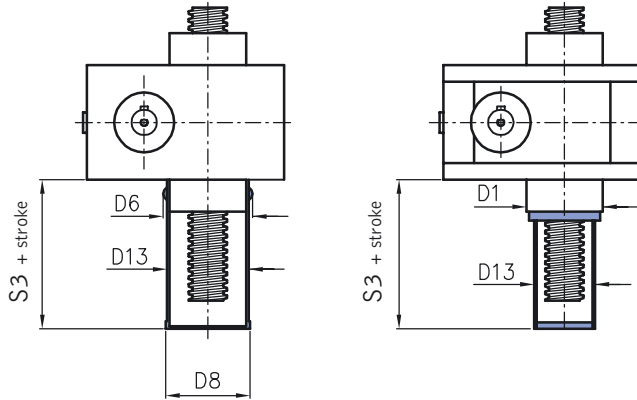

PR rigid protection														
	XPR Models*													
Size	183	204	306	407	559	7010	8010	9010	10012	12014	14014	16016	20018	25022
D1 Ø	-	-	-	-	-	-	-	-	210	210	300	300	370	370
D6 Ø	38	52	71	80	104	134	134	169	-	-	-	-	-	-
D8 Ø	34	48	65	74	97	127	127	160	-	-	-	-	-	-
D13 Ø	32	46	63	72	95	125	125	160	160	160	210	210	305	305
S3	30	50	60	75	80	80	80	100	100	100	100	100	100	100

* XPR models: stainless steel version

For non quoted dimensions see the relative tables on pages 60-63

PRO oil bath rigid protection

The application of an oil bath rigid protection, apart from representing a rigid protection, also allows to have the advantages of a semi-automatic lubrication. The lubricant must be added when mounting, with the jack completely closed, using the oil fill plug. Upon maneuvering the threaded spindle will be soaked with lubricant. **In case the threaded spindle is left out of the protection for a long period, it could dry up so to make the PRO protection useless. For long strokes, in order to compensate the pump effect, it is necessary to mount an oil recirculation pipe (TRO) allowing lubricant to flow back inside the protection from the casing. It's suggested the use of extremely high viscosity oils [2200 mm²/s] or high viscosity oils [220 mm²/s] with EP additives in percentage of 15 – 20 %. Both solutions must present EP additives for extreme pressures. We remind that the area indicated in the drawing could present lubricant drops: a vertical mounting will therefore avoid any leakage problems. The PRO protection can only be applied to TP models. The overall dimensions are shown in the following table. Incompatibility: TPR models – ALEPH series – CS, CSU, SU, SUA (pos.2) - PRF**

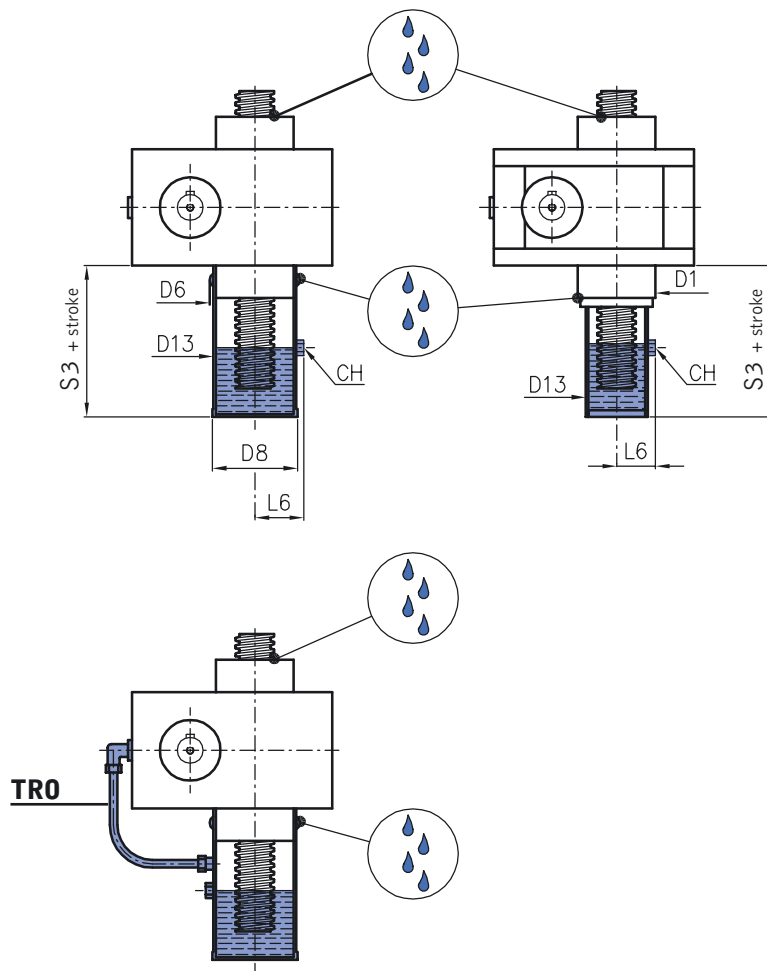

PRO oil bath rigid protection														
	XPRO Models*													
Size	183	204	306	407	559	7010	8010	9010	10012	12014	14014	16016	20018	25022
D1 Ø	-	-	-	-	-	-	-	-	210	210	300	300	370	370
D6 Ø	38	52	71	80	104	134	134	169	-	-	-	-	-	-
D8 Ø	34	48	65	74	97	127	127	160	-	-	-	-	-	-
D13 Ø	32	46	63	72	95	125	125	160	160	160	210	210	305	305
S3	30	50	60	75	80	80	80	100	100	100	100	100	100	100
L6	25	32	41	45	57	72	72	89	89	89	114	114	162	162
CH	17	17	17	17	22	22	22	22	22	22	22	22	22	22

* XPRO model: stainless steel version

For non quoted dimensions see to the relative tables on pages 60-63



CU Oil proof assembling

In some applications the service factor can be so high requesting a continuously spindle lubrication. In these cases, if the screw jack is mounted such a way not to allow oil losses from the indicated areas, it's possible a special oil proof assembling, where internal gears are lubricated in an oil bath. It's imperative that the oil fulfilling will be done with spindle in all-closed position. **In case the threaded spindle is left out of the oil proof chamber for a long period, it could dry up, so make the CU assembling useless.**

In order to guarantee the right adhesion, **it's suggested the use of extremely high viscosity oils [2200 mm²/s] or high viscosity oils [220 mm²/s] with EP additives in percentage of 15 – 20%.** Both solutions must present EP additives for extreme pressures. CU is suitable only for TP models. The overall dimensions are shown in the table below.

Incompatibility: size 183 – TPR models – ALEPH series – CS, CSU, SU, SUA (pos.2) – PRF

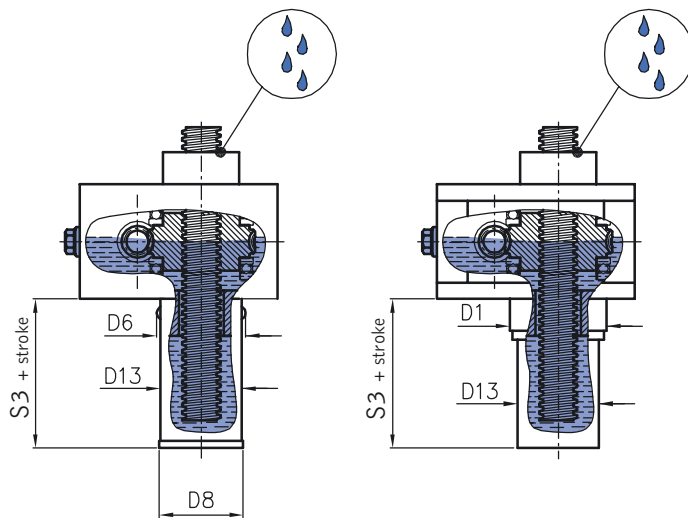

Oil proof assembling CU

Size	XCU Models*												
	204	306	407	559	7010	8010	9010	10012	12014	14014	16016	20018	25022
D1 Ø	-	-	-	-	-	-	-	210	210	300	300	370	370
D6 Ø	52	71	80	104	134	134	169	-	-	-	-	-	-
D8 Ø	48	65	74	97	127	127	160	-	-	-	-	-	-
D13 Ø	46	63	72	95	125	125	160	160	160	210	210	305	305
S3	50	60	75	80	80	80	100	100	100	100	100	100	100

* XCU model: stainless steel version

For non quoted dimensions see to the relative tables on pages 60-63

BU Anti withdrawing bush

If there's the necessity the spindle, in case of extra-stroke, not to withdraw from the jack body, it's possible assembling a steel withdrawing bush. The BU has a trapezoidal thread, able to sustain the load in extra-stroke case. The BU can apply only in TP models. In case of PRF stroke control, the BU has the function of end-of-stroke too. It's important underline that one only extra-stroke attempt (and the consequent impact between BU and the carter) can hopeless damage the transmission.

The overall dimensions are shown in the table below.

Incompatibility: TPR models – PRA

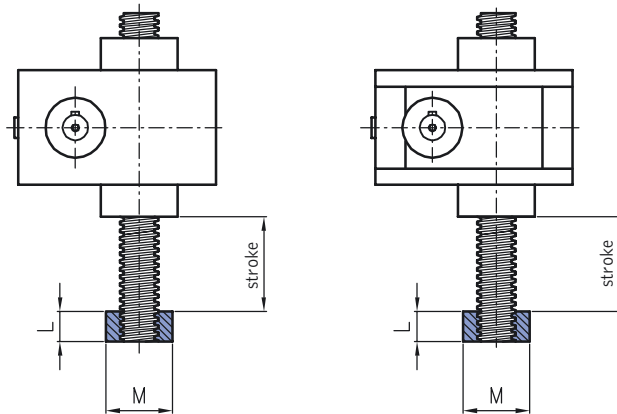

Anti withdrawing bush BU

Size	XBU Models*													
	183	204	306	407	559	7010	8010	9010	10012	12014	14014	16016	20018	25022
L	25	25	25	25	25	25	25	40	40	40	60	60	80	80
M Ø	26	38	48	58	78	88	98	137	137	145	175	190	248	298

* XBU model: stainless steel version

For non quoted dimensions see to the relative tables on pages 60-63



PRF stroke control

In order to meet the requirement of an electric stroke control it is possible to apply to a rigid protection suitable supports for end-of-stroke. In the standard version these supports are of two types and they are placed at the ends of the stroke in one of the four positions shown below. They are carried out in such a way as to allow a small adjustment. In case more than one end-of-stroke are needed, it is possible to provide intermediate supports or a continuous support for the requested length. In order to enable the end-of-stroke to operate, a steel bushing is mounted on the threaded spindle. More bushings can be mounted upon request. The PRF can only be applied to TP models and **in case of missing specifications it will be supplied with the supports mounted according to position 1**. Sensor are supplied only on demand. The overall dimensions are shown in the table below. Moreover it's possible assembling magnetic sensors on the protection, avoiding to mill it. The end-of-stroke signal is given by a magnet attached on the bottom of the spindle.

Incompatibility: TPR – PRO models - CU

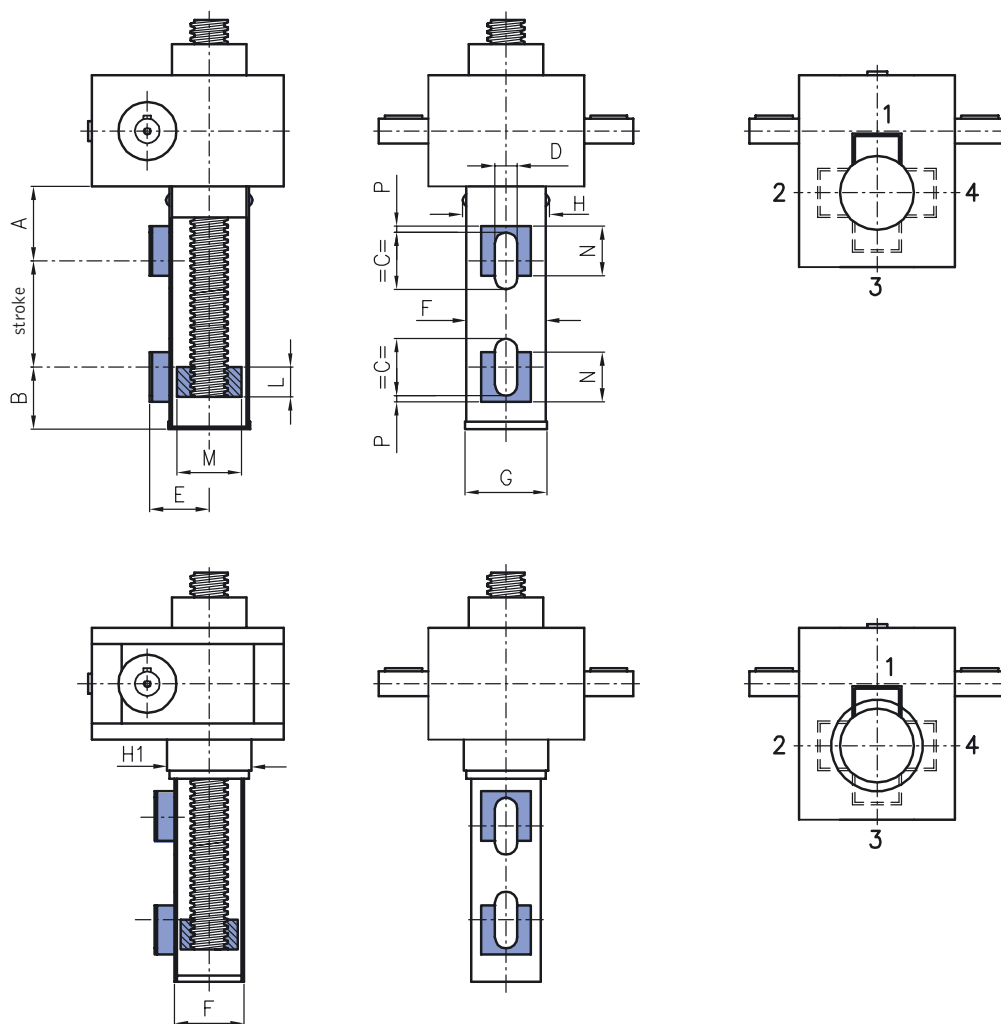

PRF stroke control

Size	XPRF Models*													
	183	204	306	407	559	7010	8010	9010	10012	12014	14014	16016	20018	25022
A	45	55	60	70	75	75	75	85	100	100	100	100	120	120
B	30	35	50	50	55	55	55	55	55	55	55	55	55	55
C	30	45	45	45	45	45	45	45	45	45	45	45	45	45
D	18	18	18	18	18	18	18	18	18	18	18	18	18	18
E	30	38	47	51	63	78	78	95	95	95	120	120	165	165
F Ø	32	46	63	72	95	125	125	160	160	160	210	210	305	305
G Ø	34	48	65	74	97	127	127	160	-	-	-	-	-	-
H Ø	38	52	71	80	104	134	134	169	-	-	-	-	-	-
H1 Ø	-	-	-	-	-	-	-	-	210	210	300	300	370	370
L	25	25	25	25	25	25	25	25	25	25	25	25	40	40
M Ø	24	38	48	58	78	88	98	130	130	136	160	180	275	275
N	25	40	40	40	40	40	40	40	40	40	40	40	40	40
P	5	5	5	5	5	5	5	5	5	5	5	5	5	5

* XPRF model: stainless steel version

For non quoted dimensions see the schemes on pages 60-63

PE elastic protection

The purpose of the elastic protections is to protect the threaded spindle by following its own movement during stroke. Standard type protections are elastic bellows, made of polyester covered nylon and can have, as serial, collars or flanges at their ends whose dimensions are shown in the table 1 below.

Special implementations are available upon request, as well as a fixing by means of iron.

Fixing flanges can be in plastic or metal. Special materials for the bellows are also available: Neoprene® and Hypalon® (water sea environment), Kevlar® (resistant to cuts and abrasion), glass fiber (for extreme temperatures, from -50 to 250°C) e aluminized carbon (it's an auto-extinguish material for limit applications with molten metal spits). **The PE standard material is guarantee for ambient temperature between -30 and 70°C.**

If it's needed a waterproof elastic bellow, it's possible to realize protections whose bellows are not sewed but heat-sealed. This kind of protection is not able to solve condensate problem. Moreover, it's possible to have metal protections on demand; such requests are be submitted to the Technical Office. Besides further implementations made of special materials fire-resistant and cold-resistant materials as well as of materials suited for aggressive oxidizing environments can be supplied.

In case of long strokes internal anti-stretching rings are previewed in order to guarantee an uniform bellows opening.

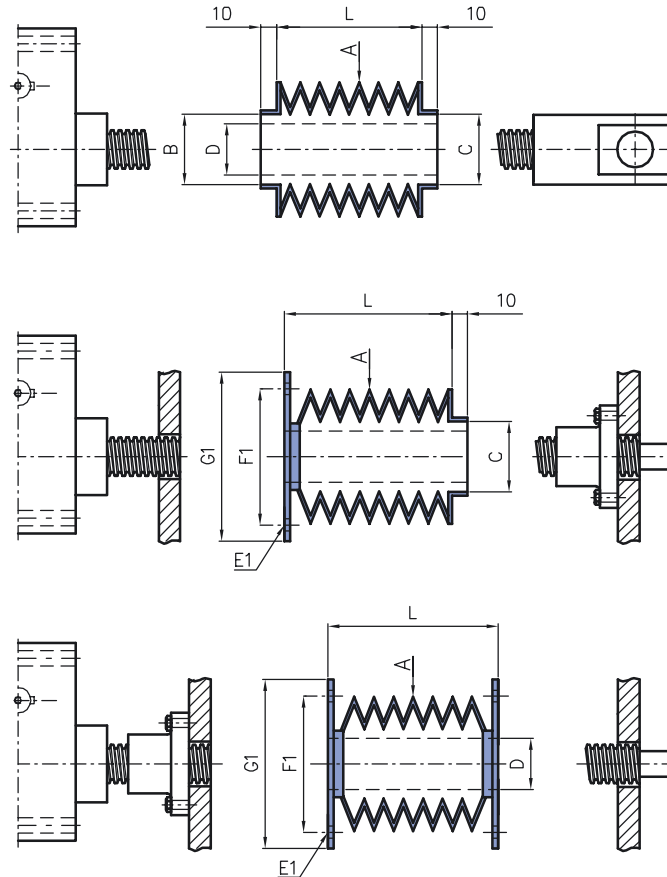

Table 1

PE elastic protection														
Size	183	204	306	407	559	7010	8010	9010	10012	12014	14014	16016	20018	25022
A Ø	70	70	85	105	120	130	140	165	165	180	210	240	270	320
B Ø	30	44	60	69	90	120	120	150	210	210	300	300	370	370
D Ø spindle	18	20	30	40	55	70	80	100	100	120	140	160	200	250
C Ø	Dimension function of the end fitting													
E1 Ø (n° of holes)	Dimension to be specified by the costumer													
F1 Ø	Dimension to be specified by the costumer													
G1 Ø	Dimension to be specified by the costumer													
L	1/8 of the stroke (completely closed)													



The application of elastic protections on the screw jacks may implicate some dimensioning amendments due to the PE own sizes, as shown in table n.2. Further, **in completely close conditions, the PE has an overall dimension equal to 1/8 of the stroke value.** In case said value exceeds the C1 quote (which can be taken from the dimension tables on pages 60-63), the total length of the threaded spindle should be fitted to said dimensions. **In case of horizontal mounting (of which previous notice should be given) it is necessary to support the protection weight itself in order to avoid that it leans on the threaded spindle;** for this purpose special support rings are foreseen. The PE can be applied to TP and TPR models and **in case of missing specifications they can be supplied with fabric collars and the dimensions shown in table 1, supposing that a vertical mounting is carried out.**
 Incompatibility: none

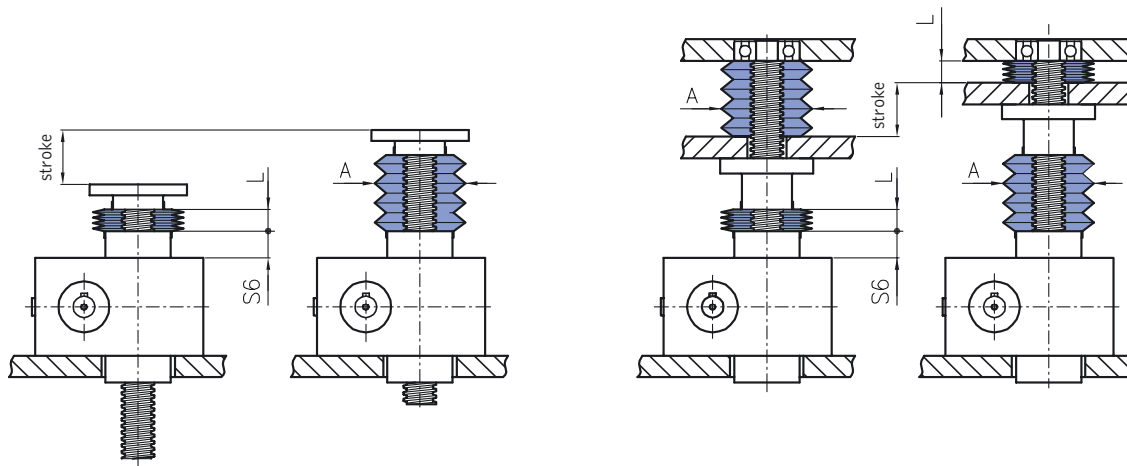

Table 2

PE elastic protection														
Size	183	204	306	407	559	7010	8010	9010	10012	12014	14014	16016	20018	25022
S6	10	20	25	35	40	40	40	50	50	50	60	60	60	60
A Ø	70	70	80	105	120	130	140	170	170	190	230	230	270	320
L	1/8 of the stroke (completely closed)													

For non quoted dimensions see the schemes on pages 60-63

PRA double guide anti-rotation

As all screw jacks must have an anti-rotation, in case such constraint cannot be realized externally, it is possible, for TP models, to have an inner anti-rotation system inside the screw jack. Two guides are mounted on the rigid protection where a bronze bushing, which is attached to the threaded spindle, can slide.

In case of very long strokes it should be checked that the torsional sliding is not such as to force the fixing screws in the guides.

As the inner anti-rotation constraints the threaded spindle and its end fitting, in case of presence of holes, like in TF and TOR end fittings, their position should be indicated, as shown in the drawings below. Unless otherwise stated all screw jacks will be delivered in position 1 or 3. The overall dimensions are shown in the table below.

Incompatibility: TPR models – ALEPH series – AR

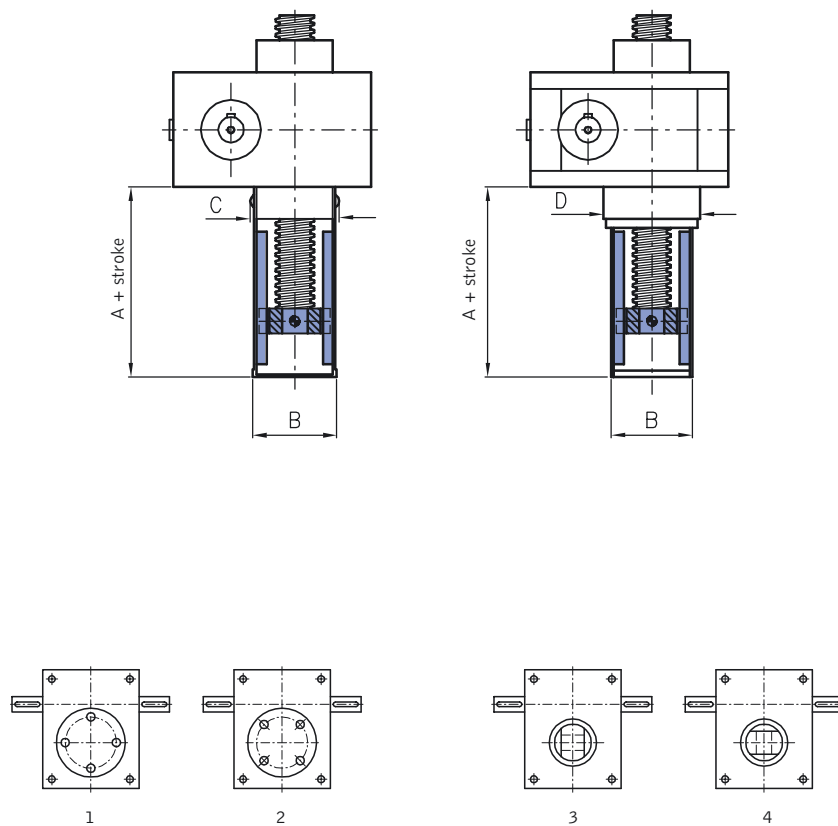

Rigid protection with PRA double guide anti-rotation

XPRA Models*

Size	183	204	306	407	559	7010	8010	9010	10012	12014	14014	16016	20018	25022
A	50	80	80	100	105	120	120	140	170	170	170	170	200	200
B	34	48	65	74	97	127	127	160	160	160	210	210	305	305
C	38	52	71	80	104	134	134	169	210	210	300	300	370	370

* XPRA Model: stainless steel version

For non quoted dimensions see the schemes on pages 60-63



AR grooved spindle anti-rotation

Another inner anti-rotation system which is only available for TP models is the grooved spindle. It provides a continuous milling along the threaded spindle length where an hardened key, having seat in the cover of the screw jack, can slide; it ensures an anti-rotation.

As this accessory foresees a cut interrupting the threads continuity, the spindle mechanical strength itself is reduced: a reduction of the load capacity has to be taken into account as reported in the table below.

In addition, also due to said grooving on the threaded spindle, in order to limit wear phenomena, the AR should be used when the f_a factor is lower than or equal to 1.

As the inner anti-rotation constraints the threaded spindle and its end fitting, in case of presence of holes, like in the TF and TOR end fittings their position should be indicated, as shown in the drawings below. Unless otherwise stated all screw jacks will be delivered in position 1 or 3.

Incompatibility: TPR models – ALEPH series – size 183 – X series – PRA

Load reduction %	204	306	407	559	7010	8010	9010	10012	12014	14014	16016	20018	25022
Static	13	8	10	7	9	8	6	6	5	5	5	4	4
Dynamic	40	25	30	20	30	25	20	20	15	15	15	10	10

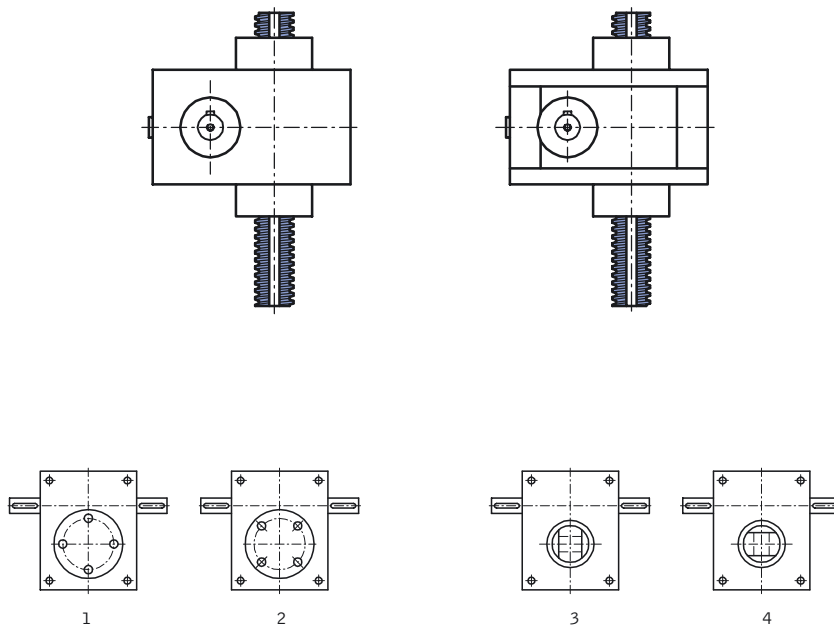

For non quoted dimensions see the schemes on pages 60-63

CS Safety lead nut for monitored wear control

In many applications it is necessary to ensure that the screw jack can safely support the load even under wear conditions of the main support nut, be it the worm wheel or the lead nut.

The safety lead nut has been designed for that purpose: it couples to the support nut through an insert and follows its movement.

When the main support nut starts wearing out, the axial backlash in the threaded spindle coupling is increased, and, under a load, the safety lead nut gets closer to the support nut, starting to support part of the force acting on it.

This phenomenon means a reduction of the L or L1 quote (according to the model). When this reduction reaches the X value indicated in the table below, the support nut and the safety lead nut must be replaced, otherwise the wear phenomena could cause a collapse of the load.

Just after mounting, it is therefore necessary to periodically measure the L or L1 quote, in order to check the wear conditions of the components. A safety lead nut only works in one way: either it ensures the traction load or the compression load support. Unless otherwise stated, all screw jacks will be delivered in the drawing configurations 1 and 3 and for a compression load. We remind that the area indicated in the drawing could present lubricant drops: a vertical mounting will therefore avoid any leakage problems. The overall dimensions are shown in the following table.

Incompatibility: ALEPH series – size 183 – RG – CSU- SU- SUA

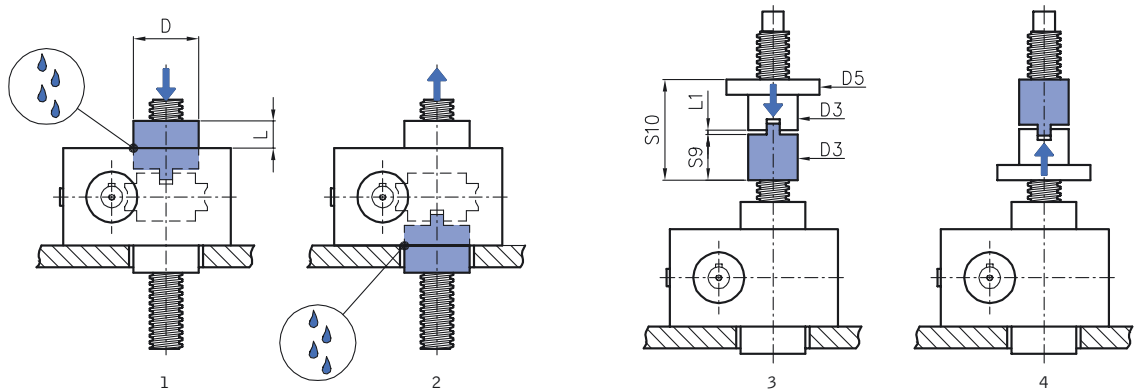

CS Safety lead nut for monitored wear control for TP models

Size	XCS Models*												
	204	306	407	559	7010	8010	9010	10012	12014	14014	16016	20018	25022
Wear border value X	1	1,5	1,75	2,25	2,5	2,5	3	3	3,5	3,5	4	5	6
D Ø	40	52	65	82	100	110	150	150	170	220	220	300	300
L ~	17	20	32	42	58	63	66	76	115	200	200	170	170

* XCS model: stainless steel version
For non quoted dimensions see the schemes on pages 60-63

CS Safety lead nut for monitored wear control for TPR models

Size	XCS Models*												
	204	306	407	559	7010	8010	9010	10012	12014	14014	16016	20018	25022
Wear border value X	1	1,5	1,75	2,25	2,5	2,5	3	3	3,5	3,5	4	5	6
D3 Ø	32	46	60	76	100	110	150	150	180	210	210	310	310
D5 Ø	60	80	96	130	180	190	230	230	280	320	320	480	480
L1 ~	2	3	3,5	4,5	5	5	6	6	7	7	8	9	11
S9	35	38	64	89	90	95	115	115	135	220	220	250	250
S10	82	89	142,5	193,5	200	210	256	256	302	477	478	559	561

For non quoted dimensions see the schemes on pages 60-63



CSU Safety lead nut for automatic wear control

When a CS safety lead nut is combined with an automatic system for controlling the X quote using a proximity switch, a CSU system is obtained. All the remarks made in the CS paragraph can also be applied to this system. The overall dimensions are shown in the following table.

Incompatibility: ALEPH series – size 183 – RG – CSU- SU- SUA

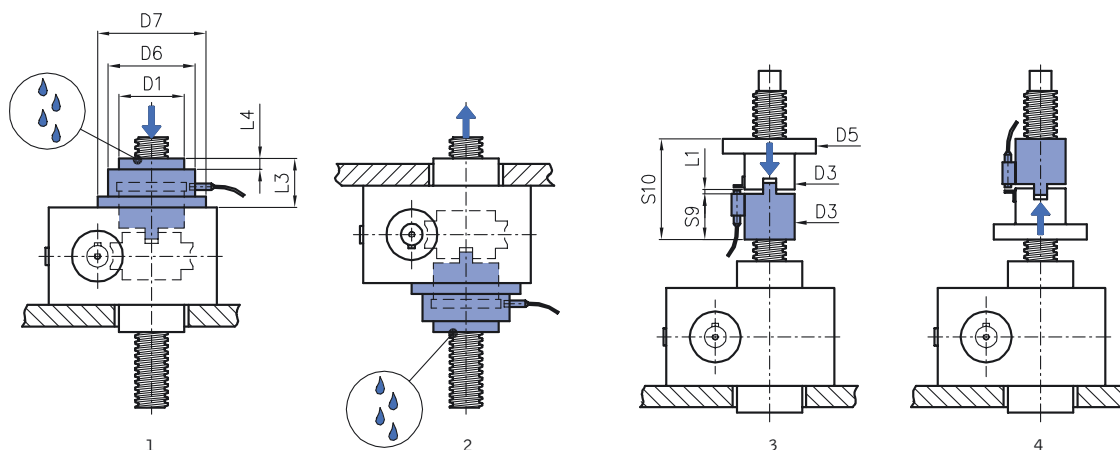

CSU Safety lead nut for automatic wear control for TP models

	XCSU Models*												
Size	204	306	407	559	7010	8010	9010	10012	12014	14014	16016	20018	25022
Wear border value X	1	1,5	1,75	2,25	2,5	2,5	3	3	3,5	3,5	4	5	6
D1 Ø	44	60	69	90	120	120	150	210	210	-	-	-	-
D6 Ø	67	88	100	120	150	150	180	200	220	270	270	380	380
D7 Ø	67	92	125,5	132	192	192	215	265	265	375	375	-	-
L3	54	60	74	84	115	115	115	145	165	250	250	295	295
L4	10	10	10	10	10	10	10	10	10	-	-	-	-

* XCSU model: stainless steel version

For non quoted dimensions see the schemes on pages 60-63

CS Safety lead nut for automatic wear control for TPR models

Size	204	306	407	559	7010	8010	9010	10012	12014	14014	16016	20018	25022
Wear border value X	1	1,5	1,75	2,25	2,5	2,5	3	3	3,5	3,5	4	5	6
D3 Ø	32	46	60	76	100	110	150	150	180	210	210	310	310
D5 Ø	60	80	96	130	180	190	230	230	280	320	320	480	480
L1 ~	2	3	3,5	4,5	5	5	6	6	7	7	8	9	11
S9	35	38	64	89	90	95	115	115	135	220	220	250	250
S10	82	89	142,5	193,5	200	210	256	256	302	477	478	559	561

For non quoted dimensions see the schemes on pages 60-63

SU Lead nut for monitored wear control

In many applications it is necessary to steady check the wear conditions of the main support nut, be it the worm wheel or the lead nut. The lead nut for monitored wear control has been designed for that purpose: it couples to the support nut through an insert and follows its movement.

When the main support nut starts wearing out, the axial backlash in the threaded spindle coupling is increased, and, under load, the safety lead nut get closer to the support nut.

This phenomenon means a reduction of the L or L1 quote (according to the model). When this reduction reaches the X value indicated in the table below, the support nut and the lead nut must be replaced, otherwise the wear phenomena could cause a collapse of the load.

The lead nut for monitored wear control is not a safety lead nut and it is therefore not designed for supporting the load. After mounting, it is therefore necessary to periodically measure the L or L1 quote, in order to check the wear conditions of the components. A lead nut for monitored wear control only works in one way: either it monitors the wear conditions under a traction load or it controls the wear condition under a compression load. Unless otherwise stated all screw jacks will be delivered in the drawing configurations 1 and 3 and for a compression load. We remind that the area indicated in the drawing could present lubricant drops: a vertical mounting will therefore avoid any leakage problems. The overall dimensions are shown in the following table.

Incompatibility: ALEPH series – size 183 – RG – CS - CSU- SUA

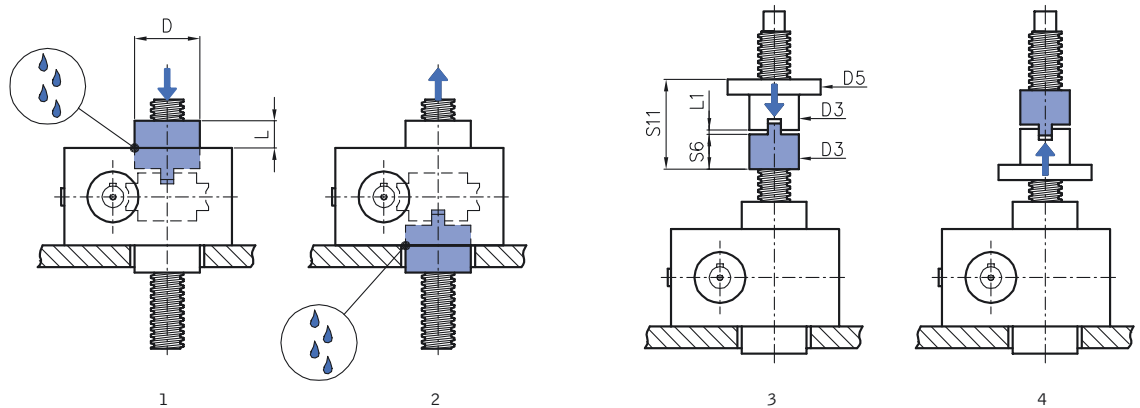

SU lead nut for monitored wear control for TP models

Size	XSU Models*												
	204	306	407	559	7010	8010	9010	10012	12014	14014	16016	20018	25022
Wear border value X	1	1,5	1,75	2,25	2,5	2,5	3	3	3,5	3,5	4	5	6
D Ø	40	52	65	82	110	110	140	150	170	220	220	300	300
L ~	8,5	11	11,5	12	12	12	13	13	14	14	14	20	20

* XSU model: stainless steel version
For non quoted dimensions see the schemes on pages 60-63

SU lead nut for monitored wear control for TPR models

Size	XSU Models*												
	204	306	407	559	7010	8010	9010	10012	12014	14014	16016	20018	25022
Wear border value X	1	1,5	1,75	2,25	2,5	2,5	3	3	3,5	3,5	4	5	6
D3 Ø	32	46	60	76	100	110	150	150	180	210	210	310	310
D5 Ø	60	80	96	130	180	190	230	230	280	320	320	480	480
L1 ~	2	3	3,5	4,5	5	5	6	6	7	7	8	9	11
S6	16	25	30	35	40	40	50	50	60	60	60	70	70
S11	63	76	108,5	139,5	150	155	191	191	227	317	318	379	381

For non quoted dimensions see the schemes on pages 60-63



SUA Safety lead nut for automatic wear control

When an SU lead nut for automatic wear control is combined with an automatic system for controlling the X quote using a proximity switch, an SUA system is obtained.

All the remarks made in the SU paragraph can also be applied to this system. The overall dimensions are shown in the following table.

Incompatibility: ALEPH series – size 183 – RG – CS – CSU – SU

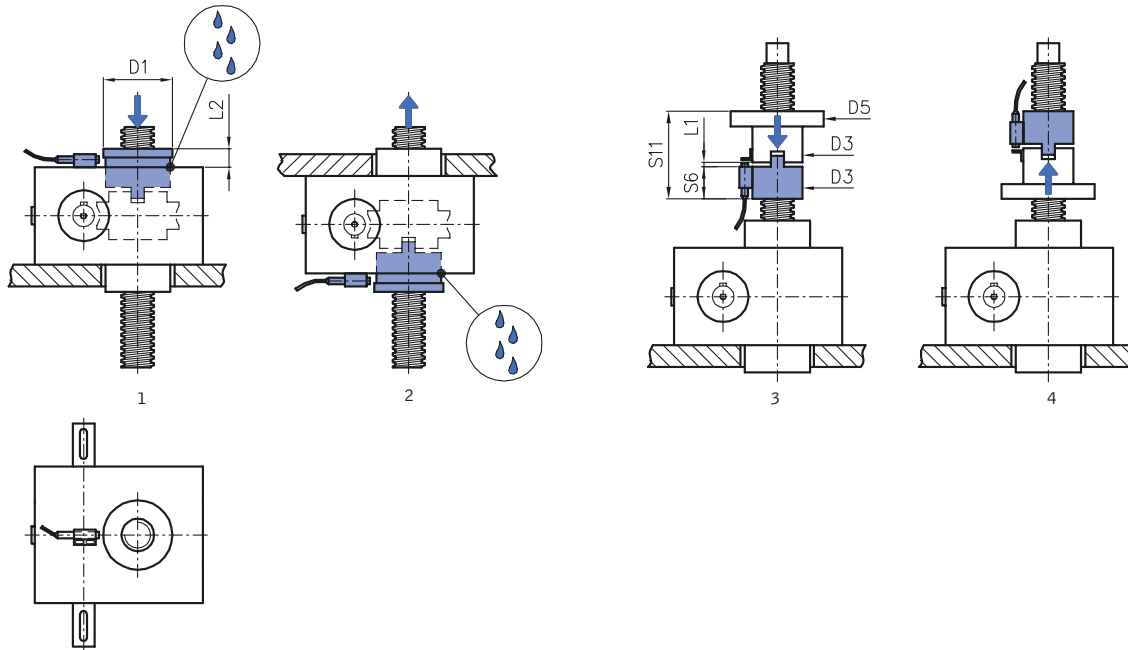

SUA lead nut for automatic wear control for TP models													
	XSUA Models*												
Size	204	306	407	559	7010	8010	9010	10012	12014	14014	16016	20018	25022
Wear border value X	1	1,5	1,75	2,25	2,5	2,5	3	3	3,5	3,5	4	5	6
D1 Ø	47	60	72	90	120	120	150	160	180	230	230	300	300
L2 ~	29	23	25,5	26	28	28	29	29	30	30	30	30	30

* XSUA model: stainless steel version

For non quoted dimensions see the schemes on pages 60-63

SUA lead nut for automatic wear control for TPR models													
Size	204	306	407	559	7010	8010	9010	10012	12014	14014	16016	20018	25022
Wear border value X	1	1,5	1,75	2,25	2,5	2,5	3	3	3,5	3,5	4	5	6
D3 Ø	32	46	60	76	100	110	150	150	180	210	210	310	310
D5 Ø	60	80	96	130	180	190	230	230	280	320	320	480	480
L1 ~	2	3	3,5	4,5	5	5	6	6	7	7	8	9	11
S6	16	25	30	35	40	40	50	50	60	60	60	70	70
S11	63	76	108,5	139,5	150	155	191	191	227	317	318	379	381

For non quoted dimensions see the schemes on pages 60-63

RG Anti axial backlash lead nut

As already explained in the previous paragraphs, the coupling between the threaded spindle and its support nut, be it the worm wheel or the lead nut, represents a natural axial backlash. If, for mounting requirements and under a load which changes its direction, from traction to compression and vice versa, it is necessary to reduce the axial backlash, an anti axial backlash lead nut can be applied. The RG lead nut is linked to the support nut through an insert and it is attached to it by means of dowels in TPR model, and by means of the contrast cover in the TP models. Closing the dowels or rotating the cover are the actions requested to reduce the axial backlash.

Be careful with an excessive backlash reduction: you could assist to huge wear phenomena and the support nut could grip on the spindle due to the difference in the two pitch errors. **The application of the anti axial backlash system reduces the screw jack running efficiency by 40%.** We remind that **the area indicated in the drawing could present lubricant drops:** a vertical mounting will therefore avoid any leakage problems. The overall dimensions are shown in the following table.

Incompatibility: ALEPH series – size 183 – CS – CSU – SU – SUA

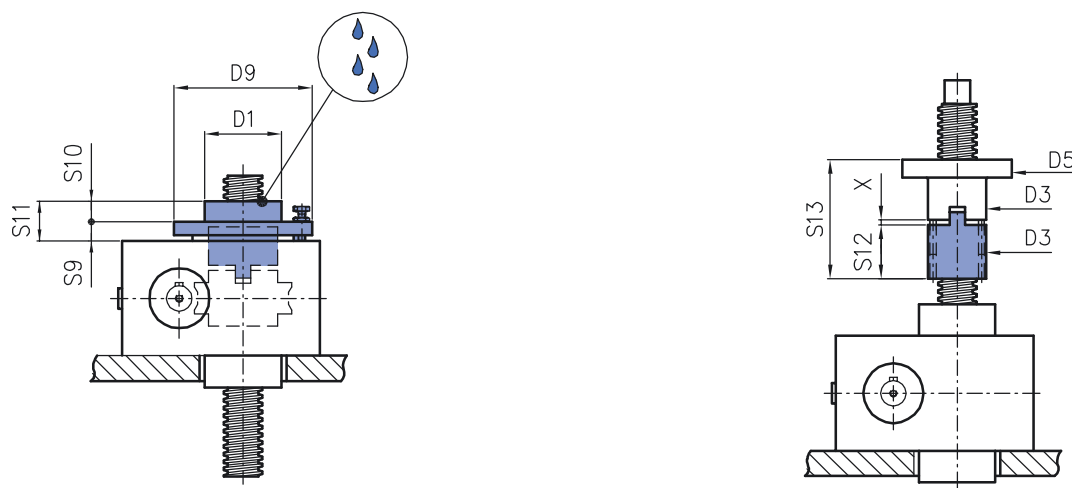

RG anti axial backlash lead nut for TP models

Size	XRG Models*						
	204	306	407	559	7010	8010	9010
D1 Ø	44	60	69	90	120	120	150
D9 Ø	62	118	150	150	230	230	215
S9	13	14	21	19	47	47	45
S10	20	15	15	19	23	23	25
S11	33	29	36	38	70	70	70

* XRG model: stainless steel version

For non quoted dimensions see the schemes on pages 60-63

RG anti axial backlash lead nut for TPR models

Size	204	306	407	559	7010	8010	9010	10012	12014	14014	16016	20018	25022
D3 Ø	32	46	60	76	100	110	150	150	180	210	210	310	310
D5 Ø	60	80	96	130	180	190	230	230	280	320	320	480	480
X ~	2	3	3,5	4,5	5	5	6	6	7	7	8	9	11
S12	35	38	84	89	90	95	115	115	135	220	220	250	250
S13	82	89	142,5	193,5	200	210	256	256	302	477	478	559	561

For non quoted dimensions see the schemes on pages 60-63



CR worm wheel rotation control

In some cases it can be necessary to check the operation conditions of the screw jack monitoring the worm wheel rotation, both in TP models and in TPR models. A milling is carried out on the worm wheel and a suitable proximity switch supplies an electric impulse for each turn. No impulse means that the transmission is stopped. Special executions with more impulses per round are always possible.

Incompatibility: ALEPH series – size 183

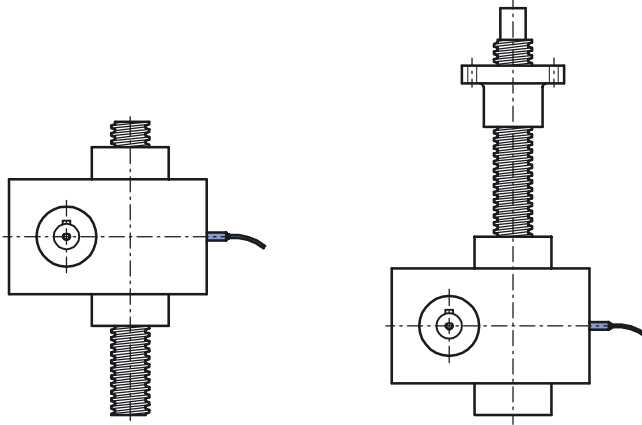

CT- CTC Temperature control

Due to the fact that they are irreversible transmissions, a big amount of input power is lost by mechanical screw jacks and it is therefore transformed into heat. It is possible to control temperature both on the casing (CT) and on the lead nut (CTC) by means of a thermal probe emitting an electric impulse when the preset temperature of 80 °C is reached. Moreover it's possible to apply a sensor able to catch the temperature exact value and to send to a plc an electric signal proportional to the above mentioned value.

Incompatibility: ALEPH series

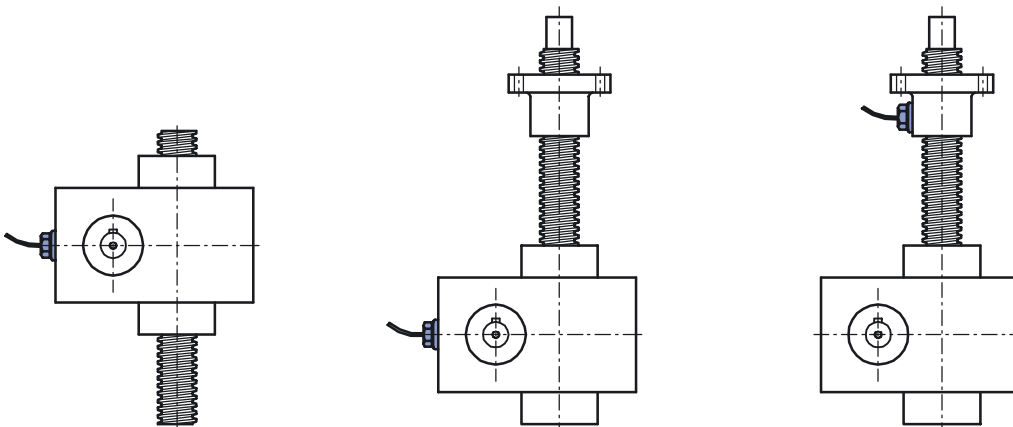

For non quoted dimensions see the schemes on pages 60-63

SP Additional mounting plates

If for mounting requirements it is necessary to fix the screw jacks on holes which do not coincide with the casing holes, steel mounting plates can be supplied.

The overall dimensions for the standard version are shown in the table below, but different fixing holes can be realized upon request.

Incompatibility: ALEPH series – sizes 183, 10012, 12014, 14014, 16016, 20018, 25022 - P - P0

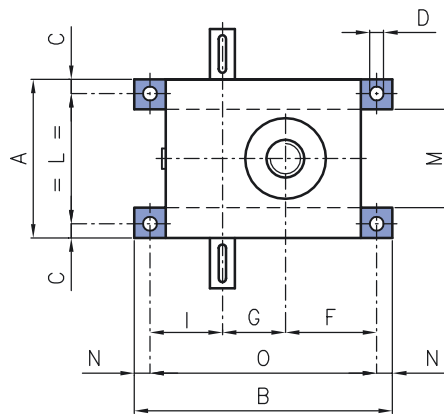
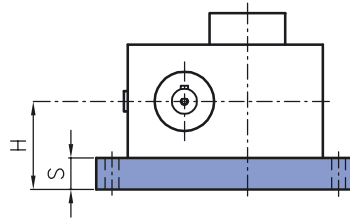

SP Additional mounting plates

Size	204	306	407	559	7010	8010	9010
A	100	126	160	170	230	230	250
B	140	205	255	291	400	400	440
C	10	12	15	18	25	25	25
D Ø	9	11	13	20	30	30	30
F	47,5	72,5	90	98	145	145	155
G	30	50	70	70	90	90	110
H	55	65	85	105	133	133	160
I	42,5	57,5	65	83	105	105	115
L	80	102	130	134	180	180	200
M	50	76	90	100	130	130	150
N	10	12,5	15	20	30	30	30
O	120	180	225	251	340	340	380
S	15	20	25	30	45	45	45

For non quoted dimensions see the schemes on pages 60-63



FP Pass-through holes for bolts

In case for mounting requirements, pass-through holes are needed for the sizes from 559 to 25022 instead of blind holes, they can be provided according to the overall dimensions shown in the table below.

Incompatibility: ALEPH series – sizes 183, 204, 306, 407

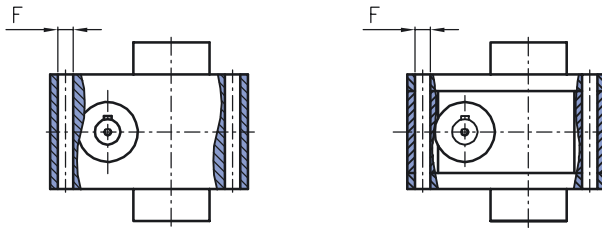

FP Pass-through holes for bolts

Size	559	7010	8010	9010	10012	12014	14014	16016	20018	25022
F Ø	20	30	30	30	30	30	56	56	66	66

For non quoted dimensions see the schemes on pages 60-63

PO Rigid rocking protection

When it is necessary to apply a rocking mounting, UNIMEC is able to offer, for TP models, a special rigid reinforced protection which has an eyelet at its end.

This protection very often supports the load, and it is therefore advisable that this protection be not too long in order to avoid an anomalous bending of the PO. Further, it should be reminded that mounting a PO in combination with an end fitting having an eyelet does not automatically give to the screw jack the status of a connecting rod (absence of lateral loads). In case of compressive loads, the buckling verification must be calculated on a length equal to the hinges distance.

Motors can directly be assembled to the screw jack. The overall dimensions are shown in the following table.

Incompatibility: TPR models - ALEPH series

sizes 183, 10012, 12014, 14014, 16016, 20018, 25022 - P - PR - PRO - SP - PRA

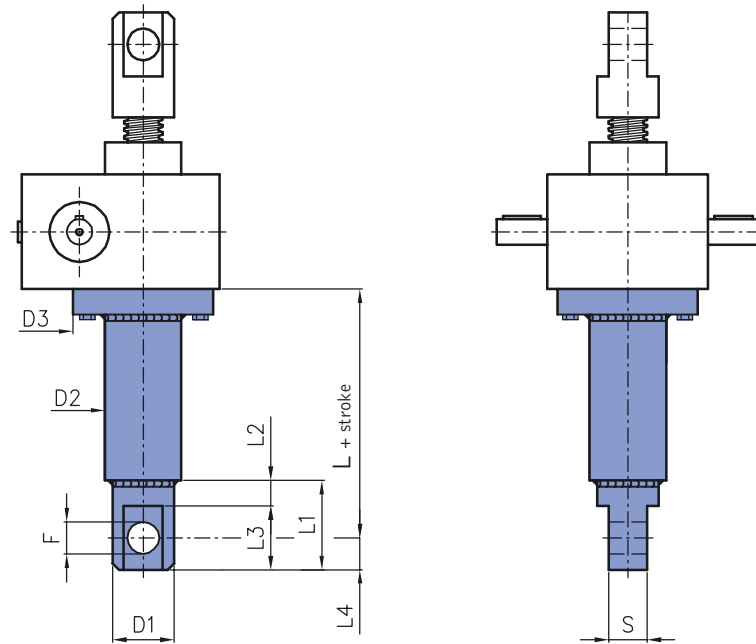

PO rigid rocking protection

Size	XPO Models*							
	204	306	407	559	7010	8010	9010	
D1 Ø	38	48	68	88	108	118	138	
D2 Ø	45	60	85	105	133	133	169	
D3 Ø	88	110	150	150	200	200	230	
F Ø H9	20	25	35	50	60	65	80	
L	90	115	145	180	210	215	280	
L1	55	70	95	140	165	175	220	
L2	15	20	25	40	45	45	60	
L3	40	50	70	100	120	130	160	
L4	20	25	35	50	60	65	80	
L5	15	20	20	20	25	25	30	
S	25	30	40	60	75	80	100	

* XPO model: stainless steel version

For non quoted dimensions see the schemes on pages 60-63



P Lateral pins

The purpose of this solution is very similar to the PO one: two lateral pins are fixed on the screw jack body in order to allow a rocking mounting. For some aspects this solution can be preferred as to the rocking protection because, in the slender rod scheme, the distance between the two hinges is exactly half.

Further we remind that mounting lateral pins combined with an end fitting having an eyelet **does not automatically give to the screw jack the status of a connecting rod (absence of lateral loads)**. In case of compressive loads, the buckling verification must be calculated on a length equal to the hinges distance.

Motors can directly be assembled to the screw jack. The overall dimensions are shown in the following table.

Incompatibility: ALEPH series - sizes 183, 10012, 12014, 14014, 16016, 20018, 25022 - PO - SP

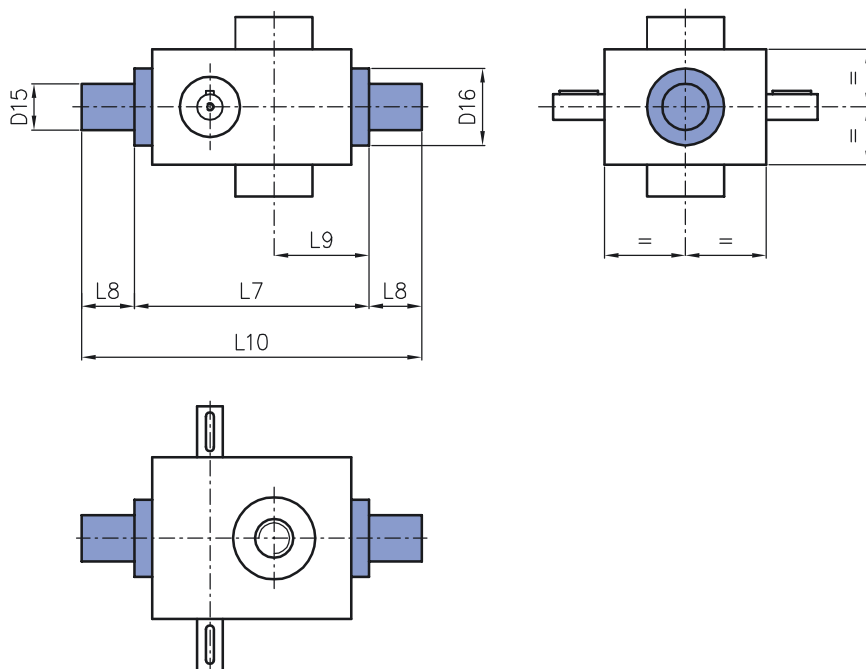

P lateral pins

Size	XP Models*							
	204	306	407	559	7010	8010	9010	
D15 Ø k6	25	30	40	50	55	60	65	
D16 Ø	55	60	70	80	95	95	100	
L7	125	180	225	261	310	310	350	
L8	30	35	45	55	60	60	65	
L9	50	72,5	90	103	130	130	140	
L10	185	250	315	371	430	430	480	

* XP model: stainless steel version

For non quoted dimensions see the schemes on pages 60-63

DA double action model

The double action model satisfies the need to move two nuts with a unique kinematic. The spindle protrudes from both screw jack faces and may have two configurations:

DXSX: the spindle is right threaded by one face and left threaded by the other one.

The kinematic presents opposite shifts, as shown in fig. 1.

DXDX: the spindle is completely right threaded. The kinematic presents the same shift direction, as shown in fig. 2.

Like kinematics, also loads can have the same or the opposite directions. This is the origin of the problems shown below. Moreover it's important that the verification at the equivalent power must be always done considering both loads.

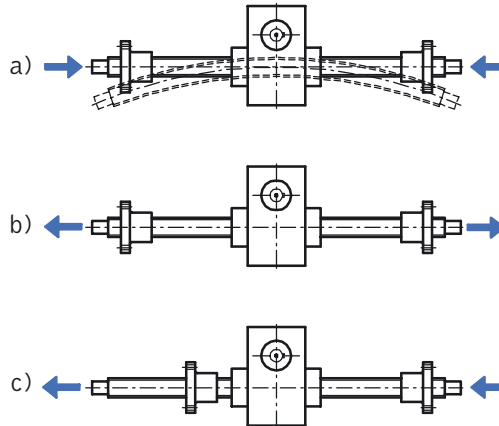

- a) The verification at buckling must be done on the spindle total length.
The maximum admissible load is the nominal of that size.
- b) The maximum admissible load is the nominal of that size
- c) The verification at buckling must be done on half spindle total length considering the structure constraints. The maximum admissible load is the half the nominal of that size.

The overall dimension C1 has to be considered on both faces and numerically correspond to the values reported in pag. 62-63 schemes.

Incompatibility: TP models – size 183, 9010, 10012, 12014, 14014, 16016, 20018, 25022

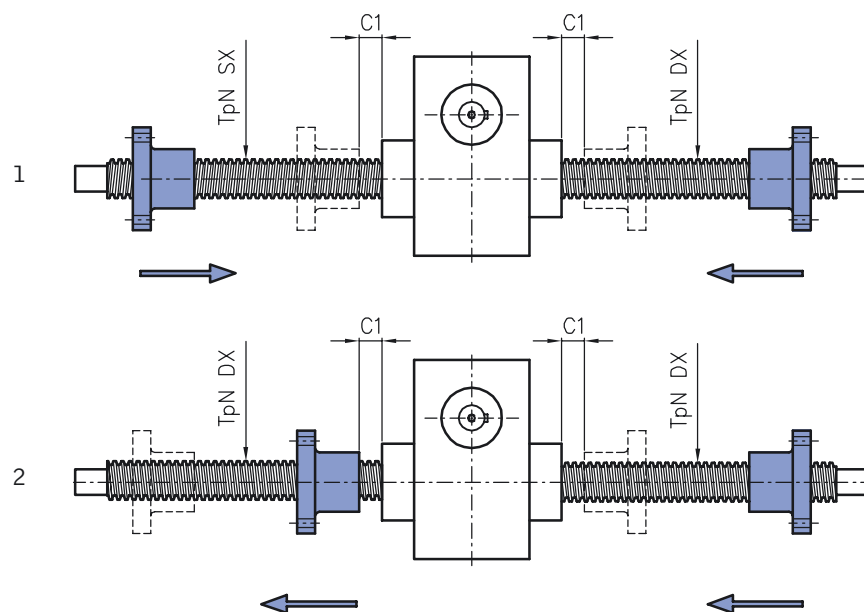

DA double action model						
	XDA Models*					
Size	204	306	407	559	7010	8010
C1	15	20	25	25	25	25

* XDA model: stainless steel version
For non quoted dimensions see schemes on pages 60-63



FD fast disassembling TPR model

In some applications (very long spindles, fast maintenance, rational expeditions) can be a good idea to disassemble a TPR spindle from the jack body without long and expansive operations like the disassembling of the elastic pins between spindle and wheel. In this case it's possible to offer a solution in which spindle is made by two crops ending with two TF terminals (look at page 64) connected by bolts. Disassembling them spindle will become two components easy to re-assemble. Obviously the nut stroke cannot extend over the double TF, and this cause a major overall axial dimension, as shown in the drawing below.

A spigot on the terminals guarantees axial alignment between the crops after reassembling.

The overall dimensions are shown in the table below.

Incompatibility: model TP – size 183, 9010, 10012, 12014, 14014, 16016, 20018, 25022

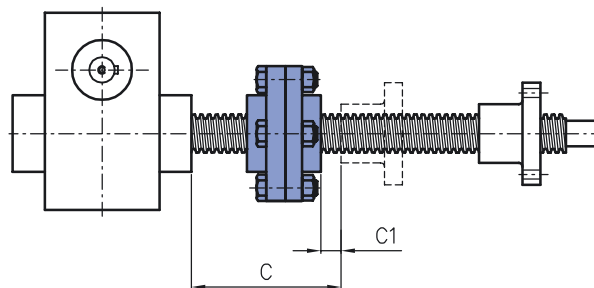

FD fast disassembling TPR model		XFD Models*					
Size		204	306	407	559	7010	8010
C		115	130	160	195	205	205
C1		15	20	25	25	25	25

* XFD model: stainless steel version
For non quoted dimensions see schemes on pages 60-63

GV Viton® seals

Due to the friction phenomena, rotating components and the seals on which they slide can locally reach high temperatures. If the previewed ones overpass 80 °C, commercial seals constitutive materials can lose their properties and damage themselves. In these cases, on demand, it's possible to use seals realized in Viton®, a special material able to be stable, up to continuous temperatures of 200 °C, to brittling and hardening phenomena.

NIPLOY treatment

For applications in oxidizing environments, it is possible to protect some screw jack components, which do not undergo any sliding, by means of a chemical nickel treatment, the so-called Niploy. It creates a **non permanent** surface coating on casings, covers, bushings, end fittings, and on the protruding shafts of the worm screw. The threaded spindle cannot undergo this treatment.

The stainless steel series

For applications where a permanent resistance to oxidizing is necessary, it is possible to supply the components in stainless steel.

Sizes **204, 306 and 407** foresee a model in AISI 316, as a **standard production**, for all components: threaded spindles, covers, bushings, casings, end fittings and motor flanges; **the only exception is the worm screw, which, on demand, undergoes a Niploy treatment in case of protrusions.**

The X series can be applied in the sea environment without any oxidizing problems. It is possible to supply all the remaining sizes in AISI 304 or 316 steel as special components. For further informations see pages 226-229.

AM Over-size spindle models

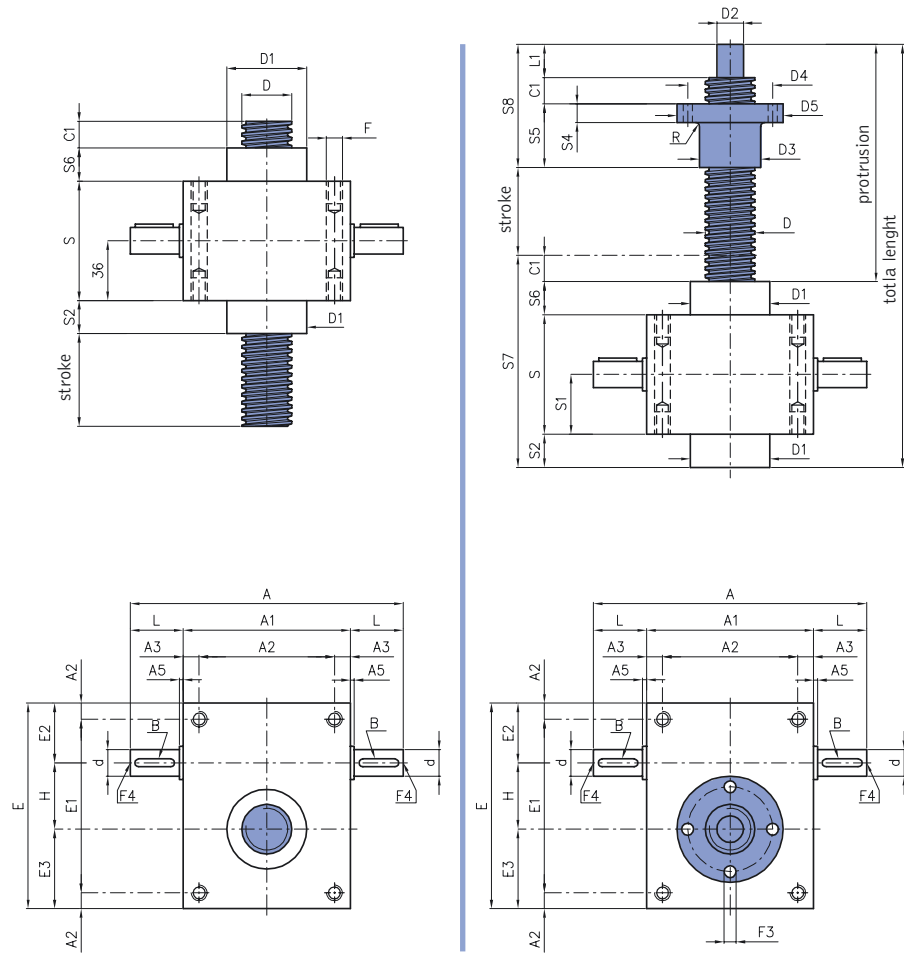

AM Over-size spindle models

Size	183	204	306	407	559
A	118	150	206	270	270
A1	70	100	126	160	170
A2	56	80	102	130	134
A3	7	10	12	15	18
A4	7	7,5	12	15	18
A5	4	-	-	-	-
B	3x3x15	4x4x20	6x6x30	8x7x40	8x7x40
C1	15	15	20	25	25
d \emptyset j6	9	12	20	25	25
D \emptyset $^{-0,2}_{-0,3}$	20x4	30x6	40x7	55x9	70x10
D1 \emptyset	30	44	60	69	90
D2 \emptyset	15	20	25	40	55
D3 \emptyset	32	46	60	76	100
D4 \emptyset	45	64	78	100	140
D5 \emptyset	60	80	96	130	180
E	94	100	155	195	211
E1	80	85	131	165	175
E2	29	32,5	45	50	63
E3	35	37,5	60	75	78
F \emptyset	9	9	11	13	M20x30
F3 \emptyset (4 holes)	7	7	9	13	18
F4 \emptyset	-	M5x10	M6x12	M8x16	M8x16
H	30	30	50	70	70
L	24	25	40	55	50
L1	20	25	30	45	70
R	3	3	3	3	3
S	50	70	90	120	150
S1	25	35	45	60	60
S2	10	20	25	35	40
S4	12	14	16	20	30
S5	45	48	75	100	105
S6	10	20	25	35	40
S7	85	125	160	215	255
S8	80	88	125	170	200



AM Over-size spindle

This construction solution, which is very useful in case a compression static load is very different from its corresponding dynamic load, consists of mounting on the screw jack a threaded spindle having the higher size. This model can be applied to TP models for sizes 183, 204, 306, and to TPR models for sizes between 183 and 559; it cannot be applied to the ALEPH series. If the model has an over-size spindle the Euler test should be performed on the higher size. It's important the load and power capacity is related to jack body size, and not to the spindle diameter. The overall dimensions are indicated in the previous page table.

NORMS

ATEX directive (94/9/CE)

The 94/9/CE directive is better known as the "ATEX directive". All UNIMEC's products may be classified as "components" according to the definition quoted in art.1 par.3 c), and therefore they do not require an ATEX mark.

A conformity declaration in accordance to what stated in art.8 par.3 can be supplied upon end user's request, subject to the filling up of a questionnaire with the indication of the working parameters.

Machinery directive (98/37/CE)

The 98/37/CE directive is better known as the "Machinery directive". UNIMEC's components are included in the products categories which do not need to affix the CE mark, as they are "intended to be incorporated or assembled with other machinery" (art.4 par.2). Upon end user's request a manufacturer declaration can be supplied in accordance to what is foreseen at Annex II, point B. The new machine directory (06/42/CE) will be acknowledged by 29/12/2009. UNIMEC guarantees that every new duty in mechanical transmission will be followed by such date.

ROHS directive (02/95/CE)

The 02/95/CE directive is better known as the "ROHS directive". All UNIMEC's suppliers of electromechanical equipments have issued a conformity certification to the above norms for their products. A copy of said certificates can be supplied upon final user's request.

REACH directive (06/121/CE)

The 06/121/CE is better known as "REACH" directive and applies as the rule CE 1907/2006. UNIMEC products present only inside lubricants as "substances", so being disciplined by art. 7 of above mentioned rule. By art. 7 par. 1 b) UNIMEC declares that its products are not subjected to any declaration or registration because the substances in them are not "to be lost in normal and reasonable previewed usage conditions"; in facts lubricant losses are typical of malfunctions or heavy anomalies. By art. 33 of the rule CE 1907/2006, UNIMEC declares that inside its products there aren't substances identified by art. 57 in percentage to be dangerous.

UNI EN ISO 9001:2000 norm

UNIMEC has always considered the company's quality system management as a very important subject. That is why, since the year 1996, UNIMEC is able to show its UNI EN ISO 9001 certification, at the beginning in accordance to the 1994 norms and now meeting the requirements of the version published in the year 2000. 13 years of company's quality, certified by UKAS, the world's most accredited certification body, take shape into an organization which is efficient at each stage of the working process. In date 31/10/2008 the new version of this norm was published. UNIMEC will evaluate every news reported in this revision.



Painting

Our products are all painted in color RAL 5015 blue. An oven-dry system enables the products to have a perfect adhesivity. Different colors as well as epoxidic paints are available.

MOUNTING SCHEMES

Scheme 1

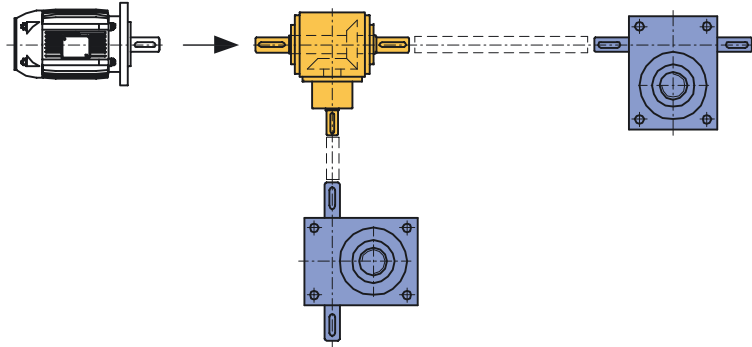

Scheme 2

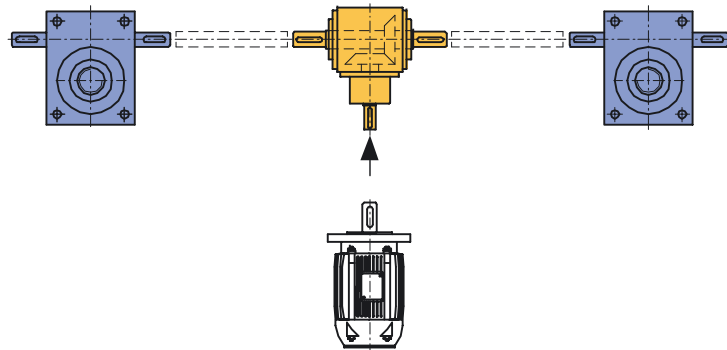

Scheme 3

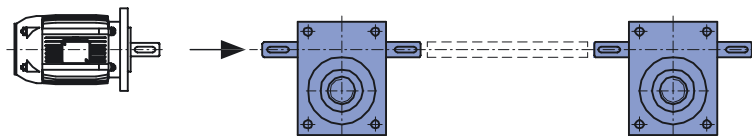

Scheme 4

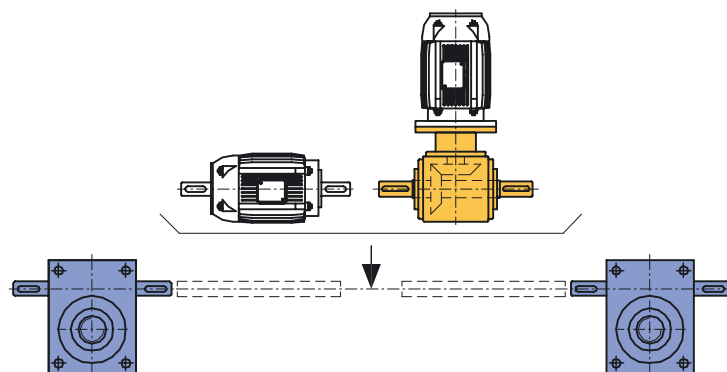

Scheme 5

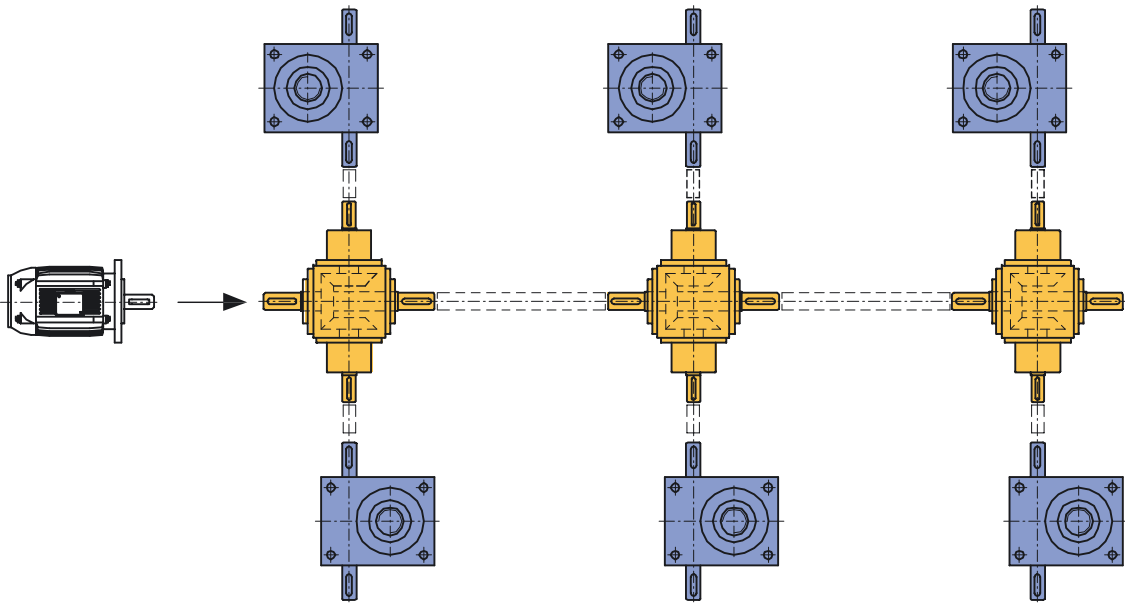

Scheme 6

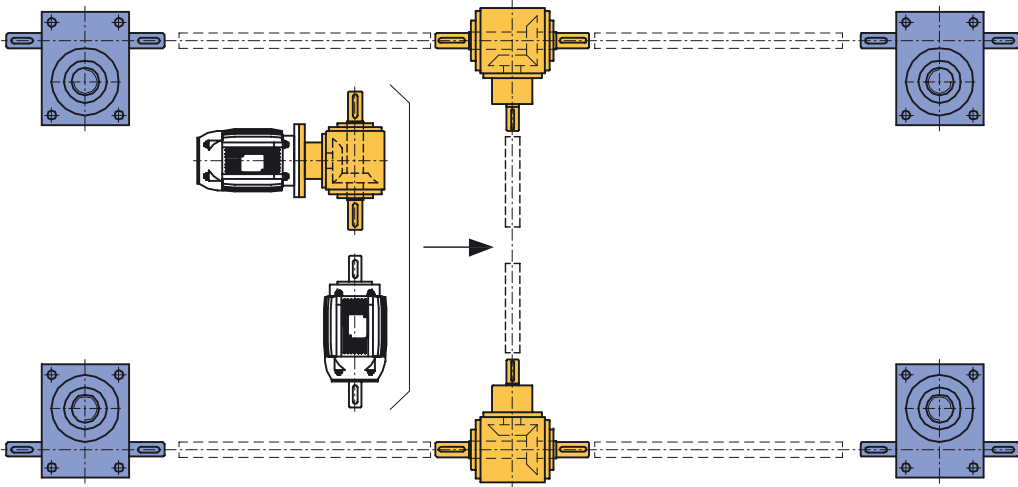

Scheme 7

