



iwis® Roller Chains, British Standard according to ISO 606 and iwis standard

ISO	iwis reference	Pitch p (")	Pitch p (mm)	Tensile strength F_b			Weight per m q (kg/m)	Inner link			Outer link			
				iwis (N) ave.	Norm (N) min.	Bearing area F (cm ²)		b_1 (mm) min.	b_2 (mm) max.	g (mm) max.	a_1 (mm) max. ²⁾	a (mm) max. ²⁾	Roller d (mm) max.	Pin d_1 (mm) max.
Simplex														
04	G 42	6 x 2.8 mm	6.00	3,000	3,000	0.07	0.12	2.80	4.10	5.00	6.70	7.60	4.00	1.85
05 B-1	G 52	8 mm x 1/8"	8.00	6,000	4,400	0.11	0.18	3.16	4.85	7.10	8.10	9.20	5.00	2.31
-	G 53 HZ ^{1) 3)}	8 mm x 3/16"	8.00	8,500	-	0.25	0.34	4.76	7.90	7.60	11.70	-	5.00	3.15
-	G 62 1/2 ¹⁾	3/8 x 5/32"	9.525	11,000	-	0.22	0.34	3.94	6.63	8.20	11.00	12.20	6.35	3.31
06 B-1	G 67 ¹⁾	3/8 x 7/32"	9.525	10,500	8,900	0.28	0.41	5.72	8.53	8.20	12.90	14.10	6.35	3.31
-	P 83 V	1/2 x 3/16"	12.70	15,500	-	0.29	0.44	4.88	7.97	10.20	13.20	14.10	7.75	3.68
-	S 84 V	1/2 x 1/4"	12.70	18,000	-	0.38	0.58	6.40	9.65	12.00	15.00	16.00	7.75	3.97
08 B-1	L 85 SL*	1/2 x 5/16"	12.70	22,000	17,800	0.50	0.70	7.75	11.30	11.80	16.90	18.50	8.51	4.45
10 B-1	M 106 SL*	5/8 x 3/8"	15.875	27,000	22,200	0.67	0.95	9.65	13.28	14.40	19.50	20.90	10.16	5.08
12 B-1	M 127 SL*	3/4 x 7/16"	19.05	32,700	28,900	0.89	1.25	11.75	15.62	16.40	22.70	23.60	12.07	5.72
16 B-1	M 1611*	1" x 17 mm	25.40	75,000	60,000	2.10	2.70	17.02	25.45	21.10	36.10	36.90	15.88	8.28
20 B-1	M 2012	1 1/4 x 3/4"	31.75	120,000	95,000	2.92	3.72	19.56	29.01	25.40	40.50	46.30	19.05	10.19
24 B-1	M 2416	1 1/2 x 1"	38.10	211,000	160,000	5.50	7.05	25.40	37.92	33.50	53.10	60.00	25.40	14.63
28 B-1	M 2819	1 3/4 x 31 mm	44.45	250,000	200,000	7.35	8.96	30.95	46.58	37.00	63.60	69.90	27.94	15.90
32 B-1	M 3219	2" x 31 mm	50.80	315,000	250,000	8.05	10.00	30.95	45.57	42.30	65.10	70.10	29.21	17.81

¹⁾ Straight side plates ²⁾ Varying dimensions for cranked links ³⁾ Bush chain

* Easy break – chains with shouldered pins

The suffix **SL** indicates chains with particular **wear-resistant pins**.

It should be noted that if cranked links are fitted, the breaking strength of the chain may be reduced by approximately 20 %.

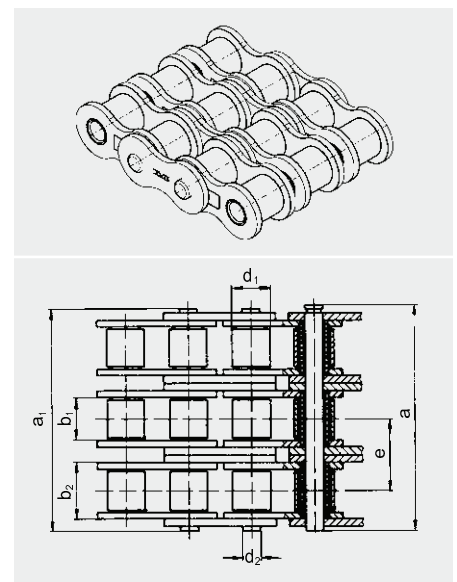
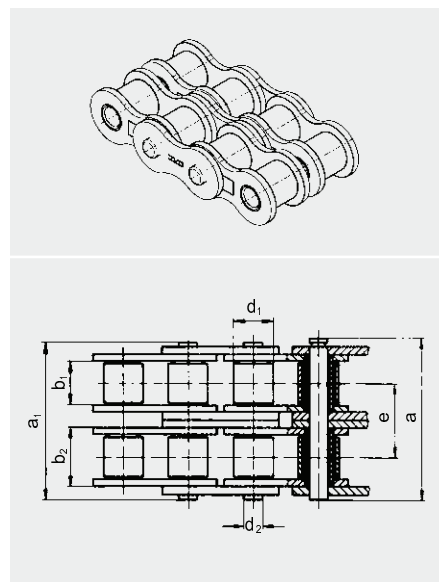
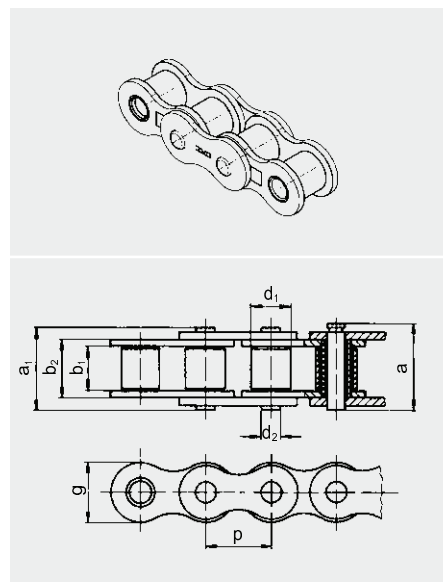



iwis® Roller Chains, British Standard according to ISO 606 and iwis standard

ISO	iwis reference	Pitch p (")	Pitch p (mm)	Tensile strength F_b			Weight per m q (kg/m)	b_1 (mm) min.	Inner link			Outer link			Pin d_2 (mm) max.	Transverse pitch e (mm)
				iwis (N) ave.	iwis (N) ave.	Bearing area F (cm ²)			b_2 (mm) max.	g (mm) max.	a_1 (mm) max. ²⁾	a (mm) max. ²⁾	Roller d (mm) max.			
Duplex																
05 B-2	D 52	8 mm x 1/8"	8.00	9,100	7,800	0.22	0.36	3.16	4.85	7.10	13.90	15.00	5.00	2.31	5.64	
06 B-2	D 67 ¹⁾ *	3/8 x 7/32"	9.525	20,000	16,900	0.56	0.78	5.72	8.53	8.20	23.40	24.60	6.35	3.31	10.24	
08 B-2	D 85 SL*	1/2 x 5/16"	12.70	40,000	31,100	1.00	1.35	7.75	11.30	11.80	30.80	32.40	8.51	4.45	13.92	
10 B-2	D 106 SL*	5/8 x 3/8"	15.875	56,000	44,500	1.34	1.85	9.65	13.28	14.40	36.00	37.50	10.16	5.08	16.59	
12 B-2	D 127*	3/4 x 7/16"	19.05	68,000	57,800	1.78	2.50	11.75	15.62	16.40	42.10	43.00	12.07	5.72	19.46	
16 B-2	D 1611*	1" x 17 mm	25.40	150,000	106,000	4.21	5.40	17.02	25.45	21.10	68.00	68.80	15.88	8.28	31.88	
20 B-2	D 2012	1 1/4 x 3/4"	31.75	210,000	170,000	5.84	7.36	19.56	29.01	25.40	79.70	82.90	19.05	10.19	36.45	
24 B-2	D 2416	1 1/2 x 1"	38.10	370,000	280,000	11.00	13.85	25.40	37.92	33.50	101.80	106.50	25.40	14.63	48.36	
28 B-2	D 2819	1 3/4" x 31 mm	44.45	500,000	360,000	14.70	18.80	30.95	46.58	37.00	124.70	129.20	27.94	15.90	59.56	
32 B-2	D 3219	2" x 31 mm	50.80	530,000	450,000	16.10	19.80	30.95	45.57	42.30	126.00	128.30	29.21	17.81	58.55	
Triplex																
08 B-3	TR 85*	1/2 x 5/16"	12.70	58,000	44,500	1.50	2.00	7.75	11.30	11.80	44.70	46.30	8.51	4.45	13.92	
10 B-3	TR 106*	5/8 x 3/8"	15.875	80,000	66,700	2.02	2.80	9.65	13.28	14.40	52.50	54.00	10.16	5.08	16.59	
12 B-3	TR 127*	3/4 x 7/16"	19.05	100,000	86,700	2.68	3.80	11.75	15.62	16.40	61.50	62.50	12.07	5.72	19.46	
16 B-3	TR 1611*	1" x 17 mm	25.40	220,000	160,000	6.32	8.00	17.02	25.45	21.10	99.20	100.70	15.88	8.28	31.88	
20 B-3	TR 2012	1 1/4 x 3/4"	31.75	315,000	250,000	8.76	11.00	19.56	29.01	25.40	116.10	119.40	19.05	10.19	36.45	
24 B-3	TR 2416	1 1/2 x 1"	38.10	560,000	425,000	16.50	20.31	25.40	37.92	33.50	150.20	155.40	25.40	14.63	48.36	
28 B-3	TR 2819	1 3/4" x 31 mm	44.45	750,000	530,000	22.05	28.00	30.95	46.58	37.00	184.60	188.90	27.94	15.90	59.56	
32 B-3	TR 3219	2" x 31 mm	50.80	795,000	670,000	24.15	29.60	30.95	45.57	42.30	184.50	186.50	29.21	17.81	58.55	

¹⁾ Straight side plates ²⁾ Varying dimensions for cranked links

* Easy break – chains with shouldered pins

The suffix **SL** indicates chains with particular **wear-resistant pins**.

It should be noted that if cranked links are fitted, the breaking strength of the chain may be reduced by approximately 20 %.

CHAIN COMPONENTS AND CONNECTING LINKS

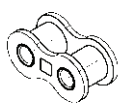

Inner link
Standard designation B

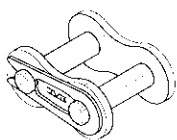

Connecting link
with spring clip
Standard designation E

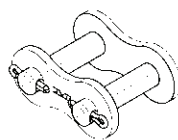

Connecting link
with split pin fastening
Standard designation S

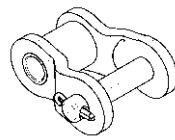

Single cranked link
with split pin fastening
Standard designation L

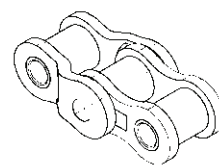

Double cranked link
Standard designation C

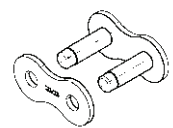

Outer link
Standard designation A



iwis® Roller Chains, American Standard (ANSI) according to ISO 606

ISO	iwis reference	ANSI Ref. no.	Pitch p (°)	Pitch p (mm)	Tensile strength F _b			Weight per m q (kg/m)	Inner link			Outer link			Transverse pitch e (mm)	
					iwis (N) av.	Norm (N) min.	Bearing area F (cm²)		b ₁ (mm) min.	b ₂ (mm) max.	g (mm) max.	a ₁ (mm) max. ²⁾	a (mm) max. ²⁾	Roller d _r (mm) max.		Pin d _p (mm) max.
Simplex																
04 C-1	G 42 A	25-1	1/4	6.35	4,909	3,500	0.11	0.13	3.18	4.80	5.80	7.820	8.62	3.30	2.31	-
06 A-1	G 67 A	35-1	3/8	9.55	10,983	7,900	0.27	0.32	4.78	7.46	9.04	11.96	12.93	5.08	3.60	-
08 A-1	L 85 A	40-1	1/2	12.70	18,000	13,900	0.44	0.60	7.92	11.17	12.06	16.60	18.54	7.95	3.98	-
10 A-1	M 106 A	50-1	5/8	15.875	29,000	21,800	0.70	1.01	9.53	13.84	15.08	20.40	22.55	10.16	5.09	-
12 A-1	M 128 A SL ¹⁾	60-1	3/4	19.05	42,000	31,300	1.06	1.47	12.70	17.75	18.09	25.44	27.99	11.91	5.96	-
16 A-1	M 1610 A	80-1	1	25.40	68,000	55,600	1.79	2.57	15.88	22.60	24.13	33.0	35.0	15.88	7.94	-
20 A-1	M 2012 A	100-1	1 1/4	31.75	112,776	87,000	2.62	3.95	19.05	27.45	30.16	39.68	43.98	19.05	9.54	-
24 A-1	M 2416 A	120-1	1 1/2	38.10	152,984	125,000	3.94	5.64	25.40	35.45	36.19	51.06	55.36	22.23	11.11	-
28 A-1	M 2816 A	140-1	1 3/4	44.45	205,940	170,000	4.73	7.38	25.40	37.18	42.22	54.54	59.44	25.40	12.71	-
32 A-1	M 3219 A	160-1	2	50.80	256,934	223,000	6.46	9.40	31.55	45.21	48.26	65.52	69.82	25.58	14.29	-
36 A-1	M 3623 A	180-1	2 1/4	57.15	374,614	281,000	8.88	12.67	35.71	50.85	54.29	73.28	78.78	35.71	17.46	-
40 A-1	M 4024 A	200-1	2 1/2	63.50	485,429	347,000	10.89	15.90	38.10	54.88	60.32	80.70	86.70	39.68	19.85	-
48 A-1	M 4830 A	240-1	3	76.20	686,466	500,000	16.15	24.40	47.63	67.81	72.39	98.70	104.70	47.63	23.81	-
Duplex																
04 C-2	D 42 A	25-2	1/4	6.35	9,218	7,000	0.22	0.25	3.18	4.80	5.80	14.22	15.02	3.30	2.31	6.40
06 A-2	D 67 A	35-2	3/8	9.53	21,967	15,800	0.56	0.63	7.78	7.46	9.04	22.42	23.12	5.08	3.60	10.13
08 A-2	D 85 A	40-2	1/2	12.70	36,000	27,800	0.88	1.22	1.92	11.17	12.06	31.00	32.98	7.95	3.98	14.38
10 A-2	D 106 A	50-2	5/8	15.875	56,000	43,600	1.40	2.00	9.53	13.84	15.08	38.60	40.72	10.16	5.09	18.11
12 A-2	D 128 A ¹⁾	60-2	3/4	19.05	84,000	62,600	2.12	2.90	12.70	17.75	18.09	48.20	50.83	11.91	5.96	22.78
16 A-2	D 1610 A	80-2	1	25.40	145,000	111,200	3.58	5.05	15.88	22.60	24.13	62.20	64.30	15.88	7.92	29.29
20 A-2	D 2012 A	100-2	1 1/4	31.75	225,553	174,000	5.24	7.86	19.05	27.45	30.16	76.28	79.18	19.05	9.54	35.76
24 A-2	D 2416 A	120-2	1 1/2	38.10	305,967	250,000	7.88	11.20	25.40	35.45	36.19	96.26	100.46	22.23	11.11	45.44
28 A-2	D 2816 A	140-2	1 3/4	44.45	411,879	340,000	9.46	14.66	25.40	37.18	42.22	103.14	108.54	25.40	12.71	48.87
32 A-2	D 3219 A	160-2	2	50.80	249,089	446,000	12.92	18.64	31.55	45.21	48.26	124.82	127.62	25.58	14.29	58.55
36 A-2	D 3623 A	180-2	2 1/4	57.15	749,228	562,000	17.76	25.14	35.71	50.85	54.29	139.12	144.62	35.71	17.46	65.84
40 A-2	D 4024 A	200-2	2 1/2	63.50	970,858	694,000	21.78	31.60	38.10	54.88	60.32	152.30	158.30	39.68	19.85	71.55
48 A-2	D 4830 A	240-2	3	76.20	1,372,931	1,000,000	32.30	48.40	47.63	67.81	72.39	186.60	192.50	47.63	23.81	87.83
Triplex																
04 C-3	TR 42 A	25-3	1/4	6.35	13,827	10,500	0.33	0.37	3.18	4.80	5.80	21.06	21.86	3.30	2.31	6.40
06 A-3	TR 67 A	35-3	3/8	9.53	32,950	23,700	0.81	0.94	4.78	7.46	9.04	32.18	33.28	5.08	3.60	10.13
08 A-3	TR 85 A	40-3	1/2	12.70	50,000	41,700	1.32	1.82	7.92	11.17	12.06	45.40	47.36	7.95	3.98	14.38
10 A-3	TR 106 A	50-3	5/8	15.875	80,000	65,400	2.10	2.89	9.53	13.84	15.08	56.70	58.93	10.16	5.09	18.11
12 A-3	TR 128 A	60-3	3/4	19.05	125,000	93,900	3.18	4.28	12.70	17.75	18.09	71.10	73.71	11.91	5.96	22.78
16 A-3	TR 1610 A	80-3	1	25.40	210,000	166,800	5.37	7.54	15.88	22.60	24.13	91.40	93.50	15.88	7.94	29.29
20 A-3	TR 2012 A	100-3	1 1/4	31.75	338,329	261,000	7.86	11.75	19.05	27.45	30.16	112.98	115.88	19.05	9.54	35.76
24 A-3	TR 2416 A	120-3	1 1/2	38.10	458,951	375,000	11.82	16.73	25.40	35.45	36.19	140.86	145.96	22.23	11.11	45.44
28 A-3	TR 2816 A	140-3	1 3/4	44.45	617,819	510,000	14.19	21.93	25.40	37.18	42.22	152.24	157.24	25.40	12.71	48.87
32 A-3	TR 3219 A	160-3	2	50.80	770,803	669,000	19.38	27.89	31.55	45.21	48.26	183.52	185.52	25.58	14.29	58.55
36 A-3	TR 3623 A	180-3	2 1/4	57.15	1,123,842	843,000	26.64	37.60	35.71	50.85	54.29	210.45	210.46	35.71	17.46	65.84
40 A-3	TR 4024 A	200-3	2 1/2	63.50	1,456,288	1,041,000	32.67	47.30	38.10	54.88	60.32	223.80	229.80	39.68	19.85	71.55
48 A-3	TR 4830 A	240-3	3	76.20	2,059,397	1,500,000	48.45	72.40	47.63	67.81	72.39	274.40	280.40	47.63	23.81	87.83

¹⁾ Also available with straight side plates ²⁾ Varying dimensions for cranked links



iwis® Roller Chains, double-pitch type according to ISO 1275

ISO	iwis reference	ANSI Ref. no.	Pitch p (°)	Pitch p (mm)	Tensile strength F _b			Weight per m			Inner link		Outer link			Transverse pitch
					iwis (N) ave.	Norm (N) min.	Bearing area F (cm ²)	q (kg/m)	b ₁ (mm) min.	b ₂ (mm) max.	g (mm) max.	a ₁ (mm) max. ²⁾	a (mm) max. ²⁾	Roller d ₁ (mm) max.	Pin d ₂ (mm) max.	e (mm)
Roller Chains, double-pitch type																
208 B	LR 165 SL	-	1	25.40	22,000	18,000	0.50	0.52	7.75	11.30	11.80	16.90	18.60	8.51	4.45	-
210 B	LR 206 SL	-	1 1/4	31.75	28,000	22,400	0.67	0.63	9.65	13.28	15.10	19.50	20.80	10.16	5.08	-
212 B	LR 247 SL	-	1 1/2	38.10	34,000	29,000	0.89	0.85	11.75	15.62	16.10	22.70	24.10	12.07	5.72	-
216 B	LR 3211	-	2	50.80	75,000	60,000	2.10	1.77	17.02	25.45	20.60	36.10	38.10	15.88	8.28	-

¹⁾ Also available with straight side plates
²⁾ Varying dimensions for cranked links

It should be noted that if cranked links are fitted, the breaking strength of the chain may be reduced by approximately 20 %. The suffix SL indicates chains with particularly wear-resistant pins.

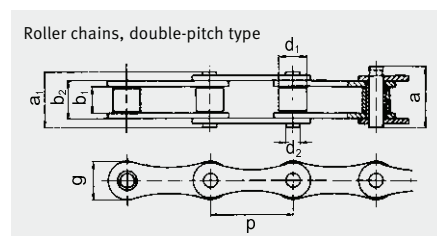

iwis® High Performance Chains

Quality products with a world reputation

HIGH QUALITY IS BASED ON EACH INDIVIDUAL PART BEING TECHNICALLY PERFECT

- Use of high-grade heat-treatable steels which are made exclusively for iwis to their material analysis, tolerance and surface quality.
- Each chain part is manufactured a million times daily to the same precision. This production is monitored by SPC (statistical process control).
- All chain parts are heat-treated, using special processes to optimize quality features.
- Constant geometry and high surface quality result from the use of modern production technologies.
- Chains are checked for dimensional accuracy: length tolerance, freedom of articulation and assembly component integrity, inspection of the press-in seating of the pin outer links and bush-inner link interfaces.
- The high standard of quality assurance conforms with the high requirements of ISO 9001.
- For special applications
 - Surface coatings
 - Special lubrications
 - Reduced length tolerated chains
 - Special materials (e.g. corrosion resistant)

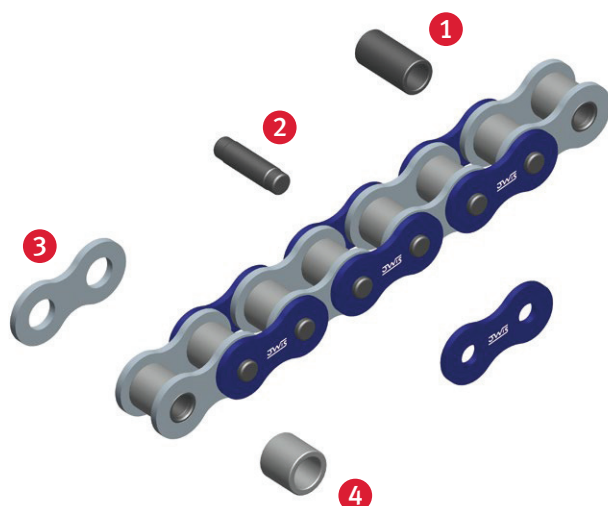

- 1 iwis bush** – manufactured as a special, surface treated cylinder and depending on the application seamless or curled
- 2 iwis shouldered pin (ISO 606):** SL chains have pins with even higher resistance to wear.
- 3 iwis side plate** – optimally dimensioned, shaped with precision, and heat-treated for toughness and hardness.
- 4 iwis roller** – an absolutely cylindrical form guarantees ideal sliding-contact bearing properties.