



Vermeire belting

Rotary shaft seals



Contents

- 1 Standard Shaft Seal Types (in accordance with DIN 3760)
- 2 Technical Data
 - 2.1 Description of rotary shaft seal
 - 2.2 Working Principle
 - 2.3 Metal case
 - 2.4 Garter spring
 - 2.5 Elastomeric Sealing Materials
- 3 Installation and operation
 - 3.1 Shaft
 - 3.2 Housing bore
 - 3.3 Lubrication
 - 3.4 Temperature
 - 3.5 Pressure
- 4 Production and Quality Assurance
 - 4.1 Press fit allowance and permissible eccentricity
 - 4.2 Final Inspection Standard
- 5 Types for special applications
 - 5.1 Radiaseal®
 - 5.2 SPLITRING®
 - 5.3 DINA Seal
- 6 Storage and Handling
- 7 Shaft seals interchange table

1 Standard Shaft Seal Types (in accordance with DIN 3760)

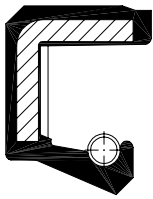

A Rubber covered O.D., metal insert, sealing lip with garter spring

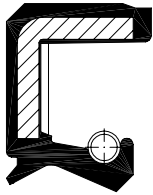

AS Rubber covered O.D., metal insert, sealing lip with garter spring and additional dust lip

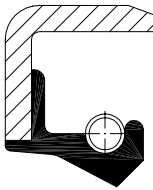

B Outer metal case, sealing lip with garter spring

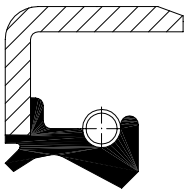

BS Outer metal case, sealing lip with garter spring and additional dust lip

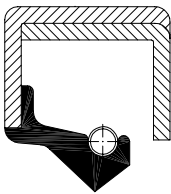

C Outer metal case with reinforcing cap, sealing lip with garter spring

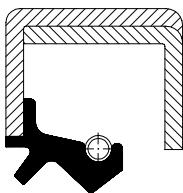

CS Outer metal case with reinforcing cap, sealing lip with garter spring and additional dust lip

Additional types

- P = reinforced sealing lip for overpressure
- O = sealing lip without spring
- DUO = twin sealing lip with two garter springs
- RD = sealing lip with hydrodynamic ribs, right rotation
- LD = sealing lip with hydrodynamic ribs, left rotation
- WD = sealing lip with bidirectional hydrodynamic ribs

2 Technical Data

2.1 Description of rotary shaft seal

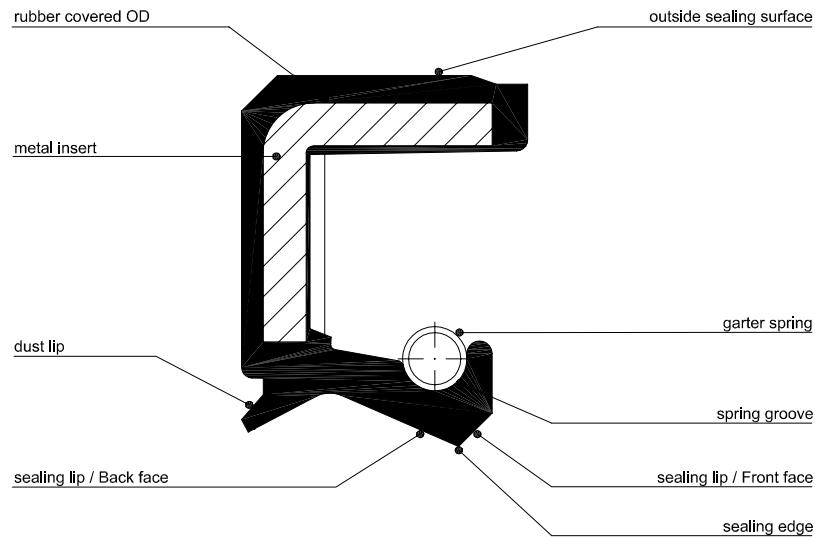

2.2 Working Principle

The area between the sealing edge and the shaft is the most important. The sealing effect is achieved by preloading the sealing lip, making its internal diameter slightly smaller than the shaft diameter. The garter spring ensures constant pressure and maintains the radial force to the shaft, flattening the sealing edge to a defined width. Underneath this flattened area a thin fluid film is formed.

Its thickness must be between 1 and 3 μm to avoid leakage. The meniscus acts as an interface between the outside air and the fluid. Any break in the meniscus will result in leakage. This can occur if the shaft contains scratches along the seal path.

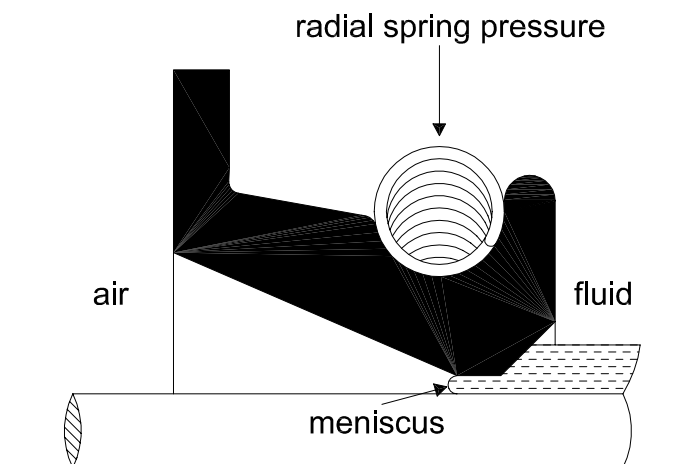

2.3 Metal case

The metal insert or case is used to give strength and rigidity to the seal.

- Normally it is made of cold rolled steel in accordance with DIN 1624.

To avoid rust or chemical attack, stainless steel can be used.

- Chrome Nickel AISI 304 (DIN 1.4301 - V2A)
- Chrome Nickel Molybdene AISI 316 TI (DIN 1.4571 - V4A)

2.4 Garter spring

The garter spring maintains the radial force exerted by the sealing lip around the shaft surface. Normally produced in harmonic spring steel wire C. 72 or stainless steel wire Chrome Nickel AISI 302 (DIN 1.4300).

For special application also stainless steel springs in AISI 316 TI (DIN 1.4571 - V4A) are available. All our standard shaft seals produced in FPM (Viton) compound are fitted with stainless steel springs in AISI 302.

2.5 Elastomeric Sealing Materials

2.5.1 NITRILE RUBBER NBR

This elastomer is a copolymer of butadiene and acrylonitrile and is used for the majority of conventional fluid sealing applications.

Physical data:

- Working temperature range: - 40° C
+120° C in oil / +90° C in water
- Tensile strength: up to 15 MPa
- Standard colour: black

Advantages:

- Good resistance to mineral oil and grease
- Good resistance to water and radiator fluid
- High tear strength

Limitations:

- Poor resistance to high-alloyed hypoid oil
- Poor resistance to ozone, weathering and sunlight
- Not resistant to automotive brake fluid (glycol based)
- Poor resistance to polar fluids (ketones, ethers, esters)
- Poor resistance to chlorinated hydrocarbons (carbon tetrachloride, trichlorethylene)
- Poor resistance to aromatic solvents

2.5.2 FLUORINATED RUBBER FPM

Mostly known under the trade names VITON from Du Pont, TECHNOFLON from Montedison and FLUOREL from 3M.

It has good chemical resistance and is recommended for high temperature applications.

Physical data:

- Working temperature range: -30° C to + 200° C
- Tensile strength: up to 15 MPa
- Standard colour: brown

Advantages:

- Excellent resistance to mineral oil and above all high-alloyed hypoid oils
- Excellent acid resistance
- Good resistance to aromatic and chlorinated hydrocarbons
- Excellent resistance to ageing, ozone and weathering

Limitations:

- Limited cold flexibility
- Poor resistance to polar fluids (ketones, ethers, esters)

2.5.3 SILICONE RUBBER SIL

Also referred to as MVQ

Physical data:

- Working temperature range: -60° C to + 200° C
- Tensile strength: approx. 3-7 MPa
- Standard colour: red

Advantages:

- Retains flexibility down to very low temperatures
- Withstands continuous heating at high temperatures without hardening
- Resistant to mineral oil and greases
- Excellent resistance to ageing, weathering and ozone
- Good chemical resistance to alkalis

Limitations:

- Not recommended for use with hydrocarbons such as petrols and paraffin, and lighter mineral oils or steam over 3.5 bar
- Not resistant to hot water, acids and non-mineral automotive brake fluids
- Poor tensile and tear strength
- Poor wear resistance

3 Installation and operation

3.1 Shaft

The shaft surface finish is of primary importance for efficient sealing and for achieving a useful life.

Basically the hardness should increase with increasing peripheral speed. According to DIN 3760 minimum hardness required is 45 HRC. At a peripheral speed of 4 m/s the hardness should be 55 HRC and at 10 m/s 60 HRC.

Lubrication is also very important. See more under chapter 3.3 of this brochure.

Surface finish as specified by DIN 3760 must be $R = 1$ to $4 \mu\text{m}$. Rougher surfaces generate higher friction, hence higher temperatures. Machining defects and scratches on the shaft must be avoided.

Even very small defects could be sufficient to increase the film thickness, eventually rupturing the meniscus and causing leakage. It is also important to avoid spiral grinding or rectifying marks, because they can cause a pumping effect and leakage.

The most used material for shafts is tempered steel. Machining tolerance is h11 according to ISO standard UNI-6388-68 (see table below).

Table 1

Shaft OD		Tolerance
From	To	h11
6	10	0 -0,090
10	18	0 -0,110
18	30	0 -0,130
30	50	0 -0,160
50	80	0 -0,190

Shaft OD		Tolerance
From	To	h11
80	120	0 -0,220
120	180	0 -0,250
180	250	0 -0,290
250	315	0 -0,320
315	400	0 -0,360

The best working condition is to have a shaft rotating perfectly centered and concentric to the axis of the rotary shaft seal. Obviously this is not possible and inevitably some eccentricity is always present. Therefore the sealing lip must compensate for it. The higher the rotation speed is, the smaller can be the permissible eccentricity which can be compensated by the sealing lip, because the inertia of the sealing lip prevents it from following the shaft movements. It is therefore advisable to install the seal immediately adjacent to the bearing and minimize bearing whip.

Dynamic shaft eccentricity

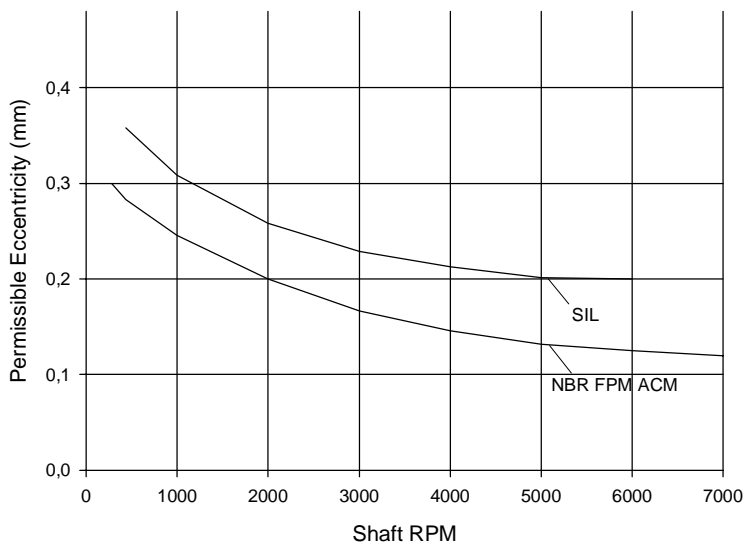

Eccentricity between shaft and housing bore must be avoided as much as possible so as to reduce unilateral load (wear) of the sealing lip.

Static shaft centre displacement

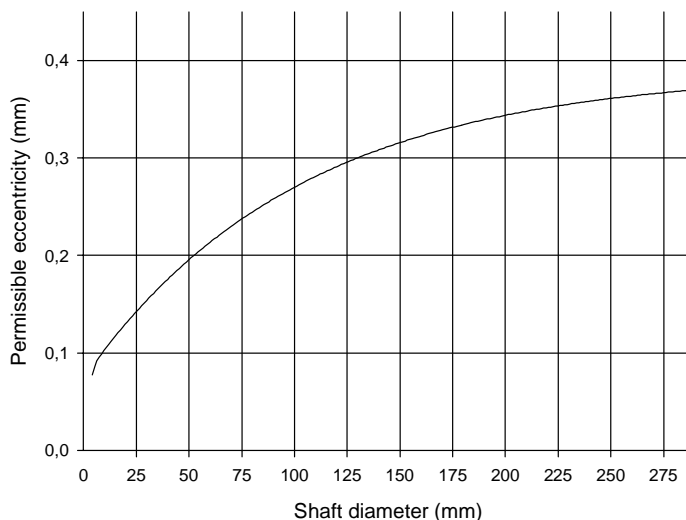

3.2 Housing bore

A good press fit of the shaft seal onto the housing bore is vital. The result is a stable installation.

Machining tolerances of the housing bore diameter for rotary shaft seals are H8 according to ISO standards UNI-6388-68 (see table below).

Housing Bore mm from	to	tolerance H8
10	18	+0,027 0
18	30	+0,033 0
30	50	+0,039 0
50	80	+0,046 0
80	120	+0,054 0

Housing Bore mm from	to	tolerance H8
120	180	+0,063 0
180	250	+0,072 0
250	315	+0,084 0
315	400	+0,089 0
400	500	+0,097 0

The maximum surface roughness of the housing according to DIN 3160 is: $R_t = 16 \mu\text{m}$. We recommend the use of a shoulder or a spacer ring against which the seal can be located. Should this not be possible one has to pay special attention that the seal is installed perpendicularly to the shaft axis. To ease installation the entrance of the groove should have a chamfer inclined by $5^\circ - 10^\circ$ and 1 mm deep for rings up to 10 mm thickness and 1.2 - 1.5 mm deep for rings thicker than 10 mm (see figure below). Also the mounting end of the shaft should have a chamfer inclined by $15^\circ - 25^\circ$, with rounded and polished edge.

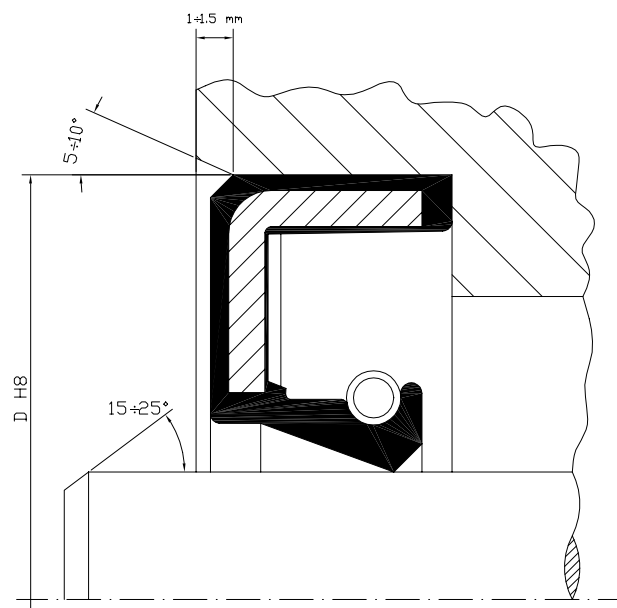

3.3 Lubrication

Lubrication is very important for good functioning of the seal. The sealing lip does not actually run on the shaft directly, but on an oil film, called meniscus (see [chapter 2.2](#)). The thickness of the meniscus is usually between 1 - 3 μm , but is influenced by many factors such as oil viscosity, shaft surface finish and seal radial load.

The first few hours of operation is called the «bedding-in» time. This is necessary not only for the meniscus to form, but also for the sealing edge to flatten. During this time limited leakage is possible.

Adequate lubrication strongly reduces friction between sealing lip and shaft and also acts as a coolant to the generated heat. The lower the temperature can be kept, the longer will be the life expectancy of the seal. Should the fluid have poor lubricating capability (water and aqueous solutions), dust lip-type (AS, BS or CS) rotary lip seals must be used. In such a case make sure to fill the space between the two lips with grease. The friction heat also depends on the peripheral speed of the shaft.

Sealing lip frictional heat

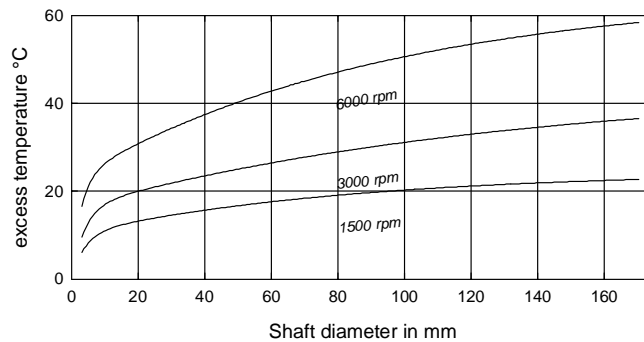

Friction not only can be detrimental to the lip material, but also can cause a power loss which could be quite significant if low power is transmitted.

Frictional power loss

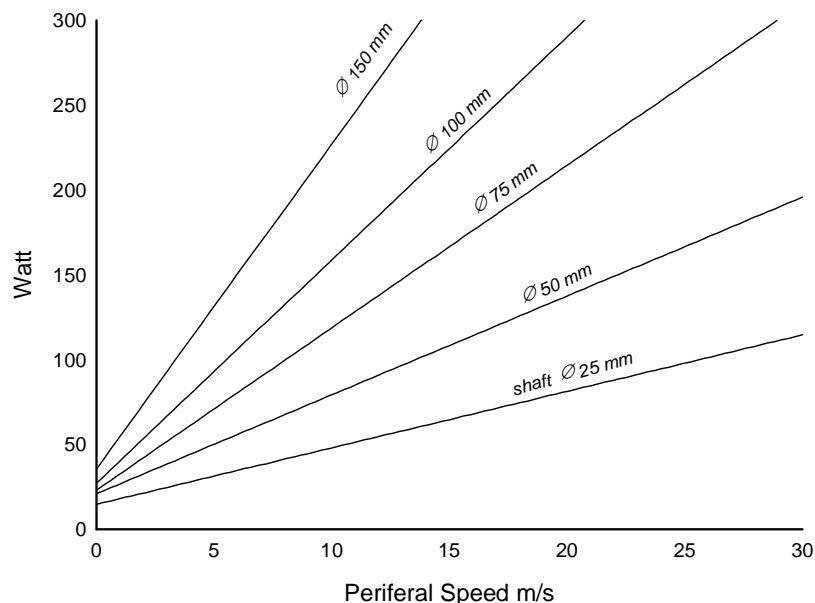

3.4 Temperature

The temperature on the sealing lip is the medium temperature increased by the temperature caused by frictional heat.

The higher the effective operating temperature is, the faster the ageing of the elastomer will be, thus affecting the performance of the sealing lip and the shaft.

Frictional heat depends on peripheral speed, sealing lip preloading, shaft surface finish, lubrication, medium, etc.

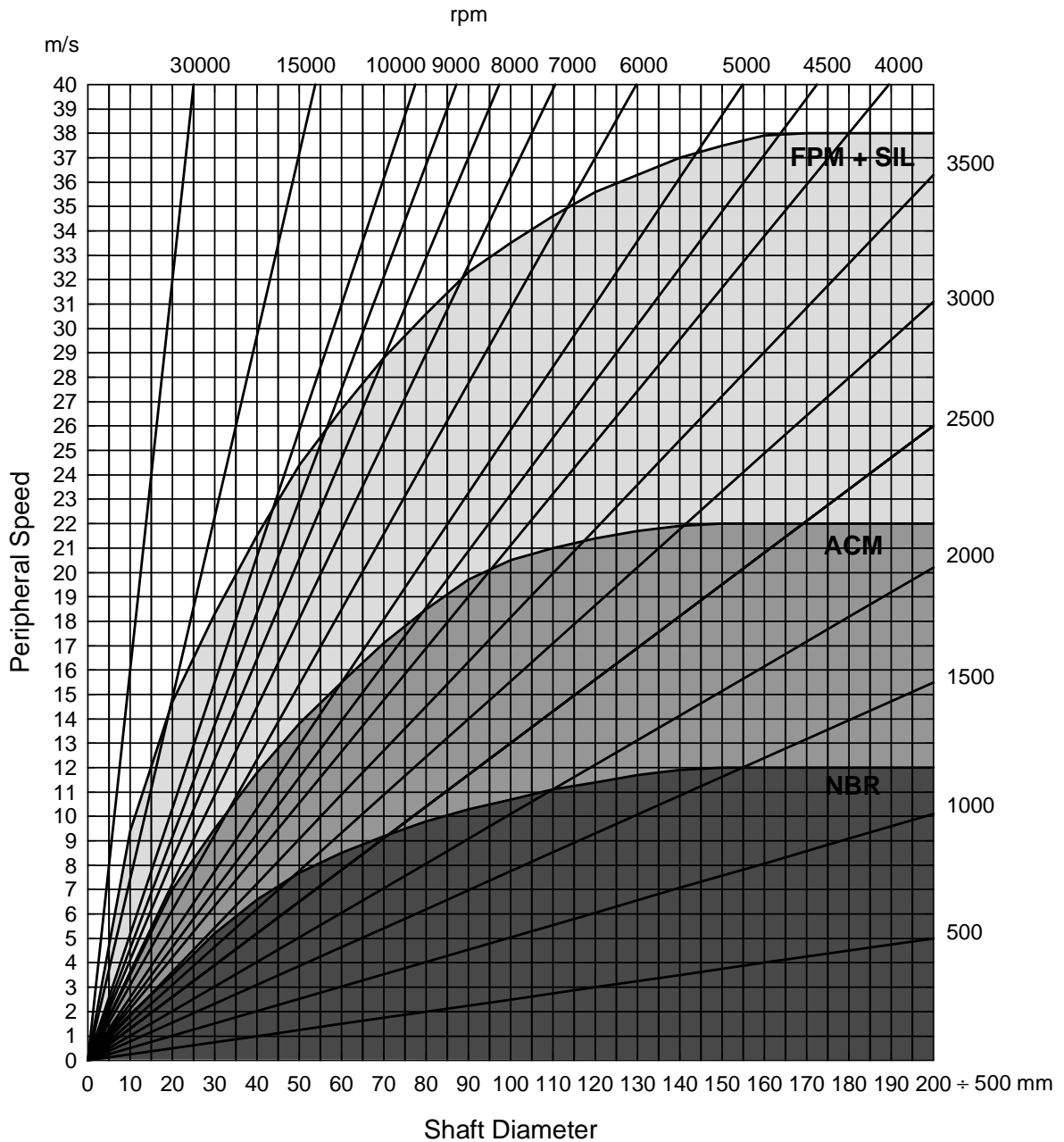

3.5 Pressure

In most applications there is no or little differential pressure. Where the rotary shaft seal is exposed to pressure, however, the sealing lip is pressed against the shaft, thus increasing temperature. In some cases the pressure can even cause overturning of the sealing lip.

Over 0,2 bar at higher peripheral speeds or over 0,5 bar at low peripheral speeds back up rings or special designed rotary shaft seals with stronger sealing lip and supporting metal insert must be used. For the latter we refer to our P-types (e.g. AS-P). Nevertheless permissible overpressures with P-type shaft seals are limited (see diagram below).

Rotary shaft seals AS-P. Permissible Overpressure

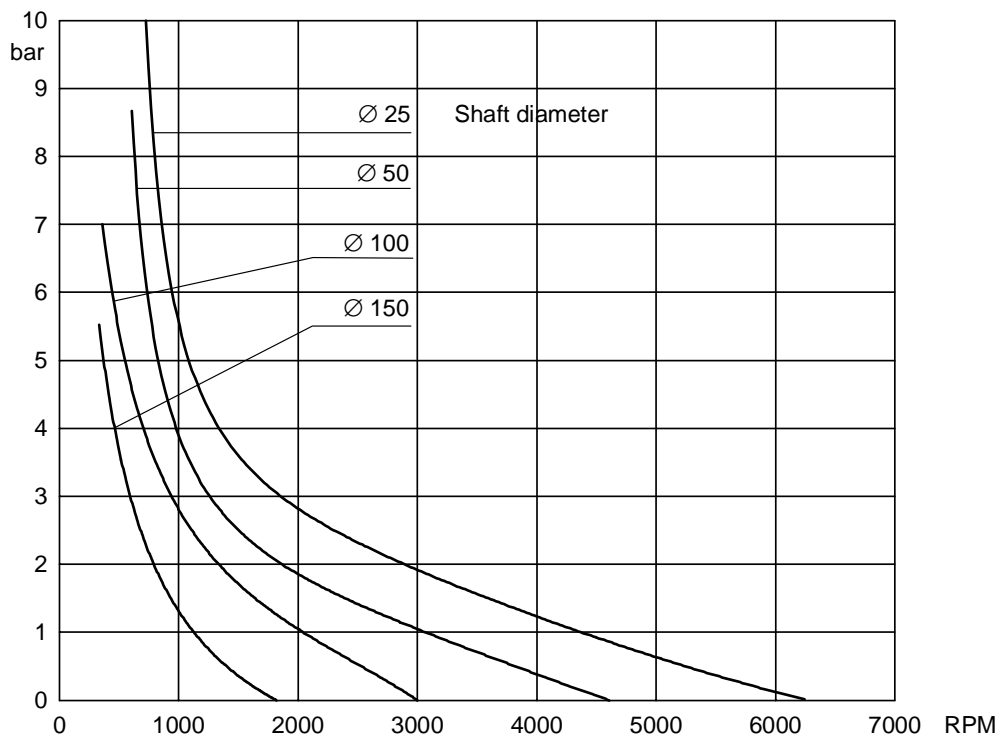

On request we can supply shaft seals with special reinforced lip to withstand pressure over the indicated value.

If back up rings are installed standard rotary shaft seals can be used. However, back up rings increase costs and often the necessary space for installation is not available. Sometimes the use of back up rings is even not possible, since it requires a very accurate fitting as well as very low eccentricity of the shaft.

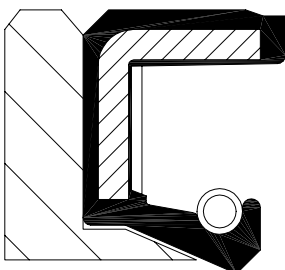

Specially designed rotary shaft seals (P-types) are therefore preferred, even if more accurate fitting and lower eccentricity of the shaft than in normal cases is required.

4 Production and Quality Assurance

Our rotary shaft seals are manufactured according to German Standard DIN 3760 and Quality assurance standards ISO 9002.

All production phases are checked and all measurements are recorded and stored for eventual tracing.

4.1 Press fit allowance and permissible eccentricity

In accordance with German Standard DIN 3760

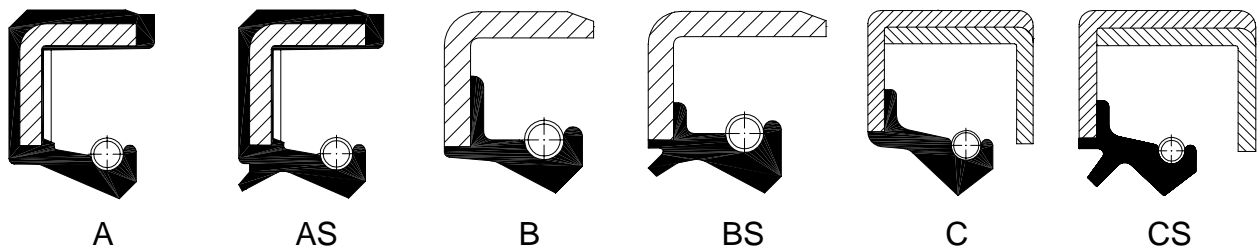

Outer diameter	Press fit allowance		Permissible eccentricity Types A,AS,B,BS,C,CS
	Types A, AS	Types B,BS,C,CS	
up to 50	+0,30 +0,15	+0,20 +0,10	0,25
over 50 to 80	+0,35 +0,20	+0,23 +0,13	0,35
over 80 to 120	+0,35 +0,20	+0,25 +0,15	0,50
over 120 to 180	+0,45 +0,25	+0,28 +0,18	0,65
over 180 to 300	+0,45 +0,25	+0,30 +0,20	0,80
over 300 to 500	+0,55 +0,30	+0,35 +0,23	1,00

The outer diameter should be measured at two locations, offset by 90°, according to DIN 3761 Part 6.

The applicable value is the average value of the two measurements, provided that permissible eccentricity is not exceeded by either measurement.

4.2 Final Inspection Standard

In accordance with our Production Standard and DIN 3761 Part 4.

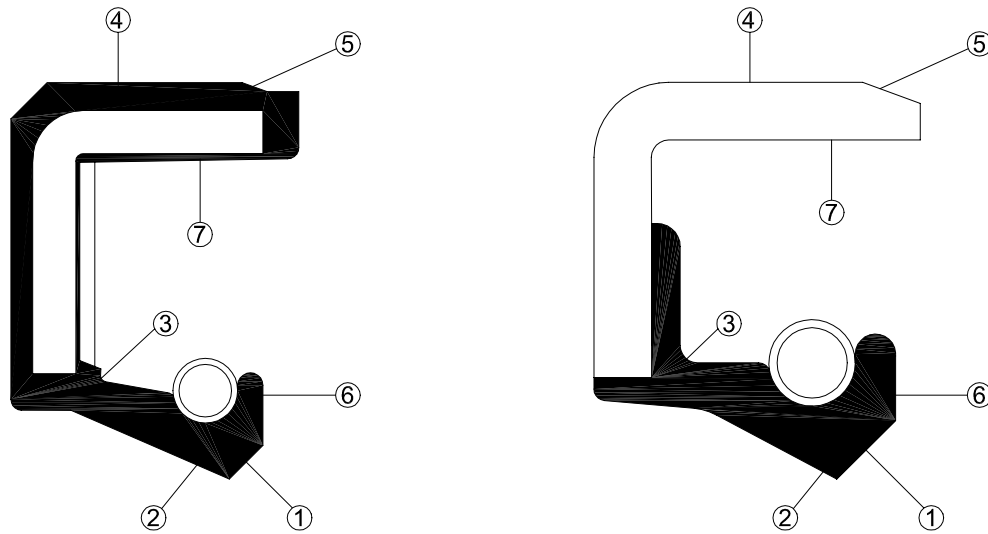

	Zone	Not permitted	Permitted
1+2	Contact band 1 = Front side 2 = Back side	Breaks in Sealing Edge	No faults permitted
3	Well of seal	Bond failures	
4	Seal O.D.	Faults which will affect the sealing on O.D.	Minor faults providing at least 2/3 of the O.D. is unbroken at this point
5	Chamfer	Faults which will affect the assembly of the seal	
6	Spring retention lip	Shorts which could cause a split	Small shortages
7	Inside wall	Loose flash	Flash permitted if bonded or secured to inside wall

The contact band width of the sealing lip is defined, according to DIN 3761 part 4, as follows:

Shaft diameter	Front band width mm	Back band width mm
Up to 50 mm	0,5	1,2
51 to 120 mm	0,8	1,5
over 121 mm	1	2

5 Types for special applications

5.1 Radiaseal®

Radiaseal® is a rotary shaft seal with fabric reinforced outer diameter, rubber sealing lip and fitted with stainless steel garter spring AISI 302 (DIN 1.4300).

Radiaseal® has been designed for use as bearing seal for roll neck application of metal rolling mills, paper mills, heavy duty gear-boxes and for marine applications.

Radiaseal® has several advantages:

- Accurate machining of housing bore is not essential.
- Easy assembly.
- No corrosion problems.
- Easy replacement.

There are 4 different types of Radiaseal® in both endless or split version.

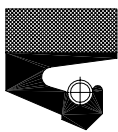

D5 standard profile



D5S with additional dust lip



D6 with ports in the base usually twin fitted back to back, with anular groove in the housing allowing lubricant to pass around to the sealing lips

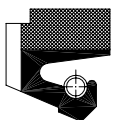

D7 with anular groove in addition to ports, allowing lubricant to pass around to the sealing lips. Usually twin fitted back to back.

Radiaseal® is standard produced in NBR elastomer. Upon request it is also available in FPM.

Fitting Instructions

- 5.1.1 Shaft tolerance ISO h9.
Surface finish roughness R_t 4 micron.
Hardness of the shaft surface 55 HRC or more.
- 5.1.2 Housing bore tolerance ISO H8.
Surface finish roughness R_t 16 micron.
- 5.1.3 Radiaseal® is manufactured with oversized O.D. and the housing must be provided with retaining plate to give controlled axial compression to the seal, to correctly locate the seal in the housing, giving good sealing on the O.D.

d = nominal shaft diameter
D = nominal bore diameter
H = shaftseal height
L = nominal bore depth

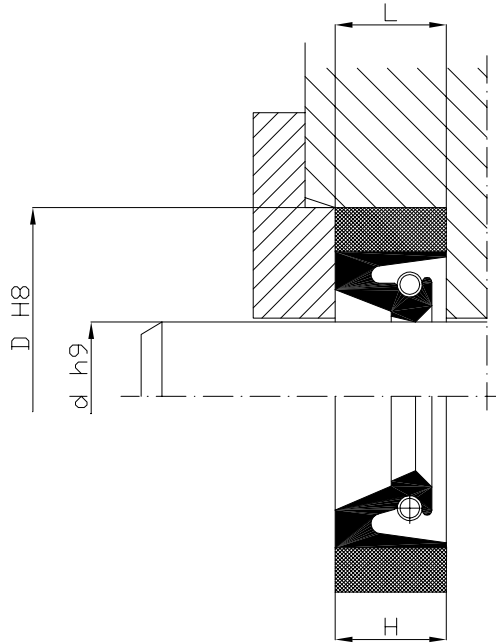

- 5.1.4 Split Radiaseal® should be installed with the split on the top and should not be used where static fluid level is higher than the lowest point of the seal. Where two Split Radiaseals are fitted together, the splits should be staggered at 30° on each side of the top.
- 5.1.5 The bore entrance and the shaft should be provided with lead-in chamfer to facilitate proper entrance of the seal into the cavity and to avoid lip damage. Length and angle of the chamfers should be according to drawing and table below.

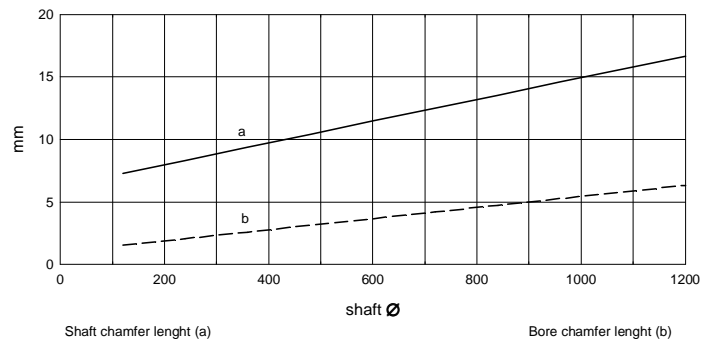
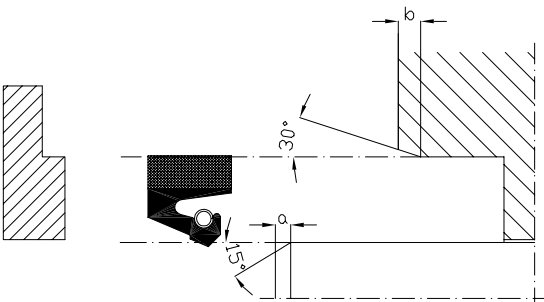

5.2 SPLITRING®

Splitring is a rotary shaft seal without metal insert, split, fitted with stainless steel coil garter spring AISI 302 (DIN 1.4300).

Splitring is used where a standard endless hard shaft seal cannot be fitted due to the presence of flanges or abutments.

Splitring can be also used to avoid high strip down costs.

Produced in standard elastomer NBR.

FPM and SIL elastomers available upon request.

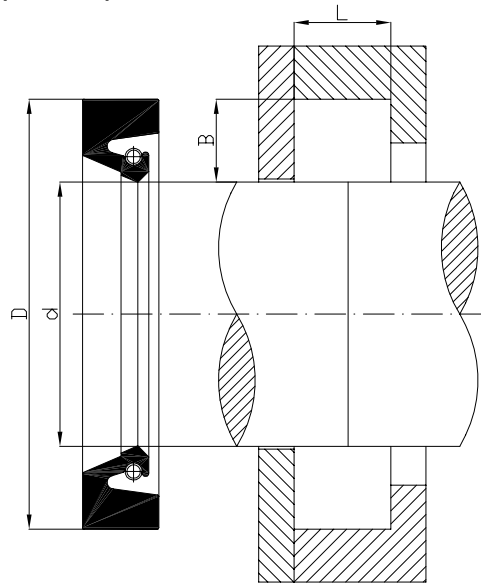

Fitting Instructions

- 5.2.1. Shaft tolerance ISO h9, surface finish max. roughness R_t 4 micron, hardness of the shaft sealing surface 55 HRC or more.
- 5.2.2. Housing bore according to table:

Shaft Diam. d	Bore Diam. D Tolerance	Bore Depth L Tolerance
Up to 140 mm	$\pm 0,12$	$\pm 0,05$
Over 140 up to 200	$\pm 0,15$	$\pm 0,07$
Over 200 up to 300	$\pm 0,15$	$\pm 0,10$
Over 300 up to 450	$\pm 0,20$	$\pm 0,12$
Over 450 mm	$\pm 0,20$	$\pm 0,15$

- 5.2.3. Splitring should be fitted with the split at the highest point of the shaft and should not be used where static fluid level is higher than the lowest point of the seal.
- 5.2.4. Clean the housing recess and remove all burrs and sharp edges. Stretch the coil garter spring around the shaft and join it by screwing the conical end into the open. Place the splitring around the shaft and stretch the spring into the groove on the sealing lip. Compress the Splitring slightly against the shaft by pressing its outside diameter and feed the seal into the housing bore starting near to the split and working around the entire periphery until the Splitring has been entered into the housing and then push the seal fully home. The housing must be provided with retaining plate to give axial compression to the seal.

5.3 DINA Seal

This is a specially designed rotary shaft seal to be used for needle bearing applications. DINA Seal is reinforced with steel insert and has a single thin lip without spring that, together with minimal interference, has low frictional loss.

To fit better into the bore DINA Seal has rubber waved Outer Diameter, except small seals up to 7 mm O.D. which have ground metal O.D.

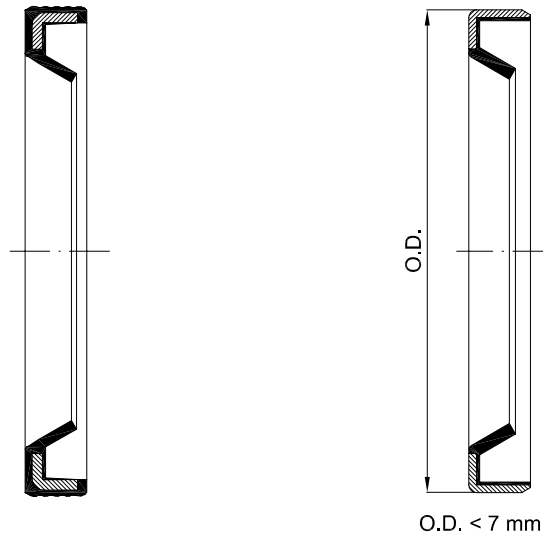

Standard DINA Seal material is are NBR elastomer and Carbon Steel insert.

For special applications also FPM and SIL elastomers and/or stainless steel insert are available upon request.

DINA Seal can be used to prevent lubricant leakage if mounted with the front face near to the needle bearing, or to protect the bearing from dust and dirt entry if mounted with the back face near to it.

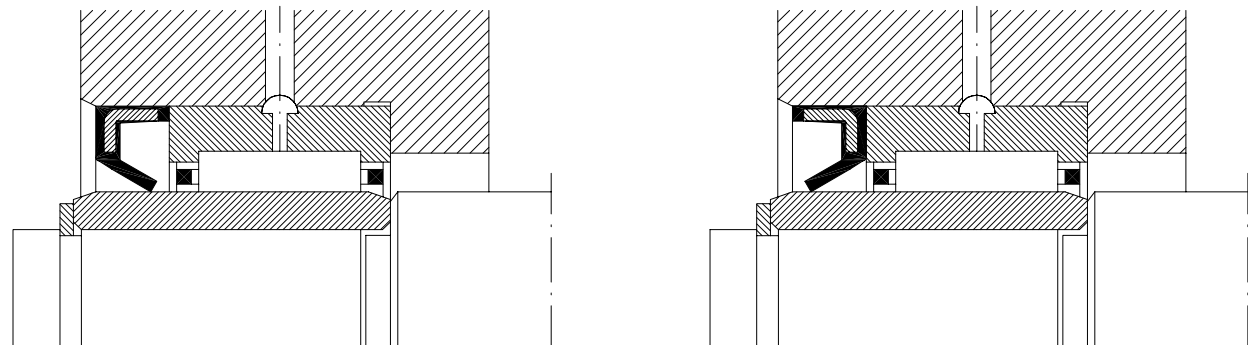

6 Storage and Handling

Some storage precautions must be taken in order to avoid deterioration of the material.

Rotary shaft seals should be stored in a dust free and dry atmosphere and they must be kept in their original wrapping which should only be opened just before installation. Samples should be repacked after inspection. Excessive humidity will deteriorate some elastomers as well as cause corrosive damage to metal casing and spring.

Do not drop rotary shaft seals on shelves or boxes, nor hang seals on hooks, wires or nails, since in either case the sealing lip can be damaged. Seals should be stored in a horizontal position.

Seals should be used on a first-in first-out basis to avoid ageing on the shelf. Avoid storage near sources of heat or near electrical equipment that may generate ozone. Also keep away from direct sun light.

7 Shaft seals interchange table

Dichta types	A	AS	AS-P	A-O	A-DUO	B	BS	C	CS
Simrit-Freudenberg	BA	BASL	BABSL	BAOF	BADUO	B1	B1SL	B2	B2SL
Goetze	827N	827S	827SK	827N0	827D	822N	822S	824N	824S
Kako	DG	DGS	DGSP	DE	DGD	DF	DFS	DFK	DFSK
Simmerwerke	A	ASL		AOF	ADUO	B	BSL	C	CSL
Stefa	CB	CC	CF	CD	CK	BB	BC	DB	DC
Gaco	A	FA		SA	DUPLEX	ABI			
Pioneer Weston	R21	R23		R26	R22	R4	R6	R1	
Paulstra	IE	IEL		IO	IELR	EE	EEL	EEP	
Chicago Rawhide						CRW1	CRWA1	CRWH1	CRWHA1
National	35	32				48	47	45	41