

# FRENIC MEGA



*Maximum Engineering for Global Advantage*

The High Performance Multifunctional Inverter



## Performance reaching the peak in the industry

### Why FRENIC-MEGA?

- Able to drive induction and permanent magnet synchronous motors
- Built-in EMC filter as standard
- STO compliant to EN 61800-5-2 SIL 2 and EN ISO 13849-1 PL d Cat. 3
- Ability to handle up to 3 simultaneous option cards (3 ports)
- Keypad with a USB connector
- Built-in braking transistor up to 22 kW (standard) and 160 kW (option)
- Full network support
- 4 complete motor maps

# FRENIC MEGA



FRENIC-MEGA G1 Series



### Improved control performance

- Motor control methods: PG vector control, sensorless vector control, dynamic torque vector control, and V/f control.
- Improved performance of current response and speed response (vector control)
- Improved durability in overload operation
  - ◆ HD (high duty) spec: 200% for 3 sec / 150% for 1 min
  - ◆ LD (low duty) spec: 120% for 1 min

### Lower maintenance

- Maintenance warning output signal
- Use of parts with a longer life cycle



## The general purpose inverter with convincing vector control

### Maximizing the performance of a general purpose motor: closed loop vector control

- Effective in providing highly accurate control for applications such as offset printing, hoisting, winding and wire drawing
  - ◆ Speed control range: 1:1500
  - ◆ Speed response: 100 Hz
  - ◆ Speed control accuracy:  $\pm 0.01\%$
  - ◆ Current response: 500 Hz
  - ◆ Torque accuracy:  $\pm 10\%$

### Dynamic torque vector control by Fuji Electric

- Dynamic torque vector control has been improved to achieve a high starting torque of 200% even at a low-speed rotation of 0.3 Hz. This is a new method introduced by Fuji Electric.

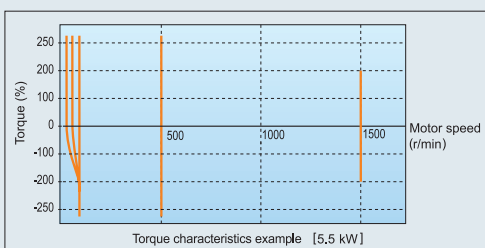

### Maximizing the performance of a general purpose motor: sensorless vector control

- Effective in providing highly accurate control for applications such as offset printing, hoisting, winding and wire drawing
  - ◆ Speed control range: 1:200
  - ◆ Speed response: 20 Hz
  - ◆ Speed control accuracy:  $\pm 0.5\%$
  - ◆ Current response: 500 Hz
  - ◆ Torque accuracy:  $\pm 10\%$
  - ◆ Zero speed torque: 100%  $\pm 20\%$

### Improved durability during overload condition

- The MEGA G1 inverter performs short-time acceleration and deceleration with the maximum capacity by achieving better overload time than our previous models. This improves the operation efficiency of the equipment such as a cutting machine or conveyors. Overload capability: 200% for 3 sec. and 150% for 1 min. The standard model is available in two specifications concerning the operation load.

Classification	Overload current rating	Major use
HD (high duty) spec	200% for 3 sec, 150% for 1 min	Operation under heavy load
LD (low duty) spec	120% for 1 min	Operation under light load

### Permanent magnet synchronous motor control\*

- FRENIC-MEGA can drive permanent magnet synchronous motors, both sensorless (open loop) and with speed feedback (closed loop).

\*Special product version.

### Dedicated brake control function

- Torque values are now included in the brake releasing conditions, which ensures that motor torque is generated, and therefore brake signal is more reliable.

### Expanded capacity for the brake circuit built-in models

■ A brake circuit is built in the 22 kW or smaller models as a standard feature. These inverters are suitable to be used in machines with regenerative load such as vertical conveyance machines. The 7.5 kW or smaller models also incorporate a braking resistor. A built-in brake circuit can be manufactured on request in the types from 30 kW to 160 kW (400 V series).

### Quicker response to the operation commands

■ The terminal response to the operation commands has had an established reputation. FRENIC-MEGA has further shortened this response time, achieving the industry-top response time. This function is effective in shortening the time per cycle and effective for use in the process including frequent repetitions.

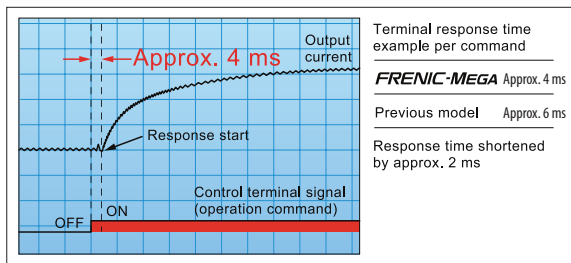

### Improved reaction to the fluctuation of impact load

■ When a large load fluctuation occurs, the inverter provides the fastest torque response in its class. It controls the flux to minimize the fluctuation in the motor speed while suppressing the vibration. This function is best suited for the equipment that requires stable speed such as a cutting machine.

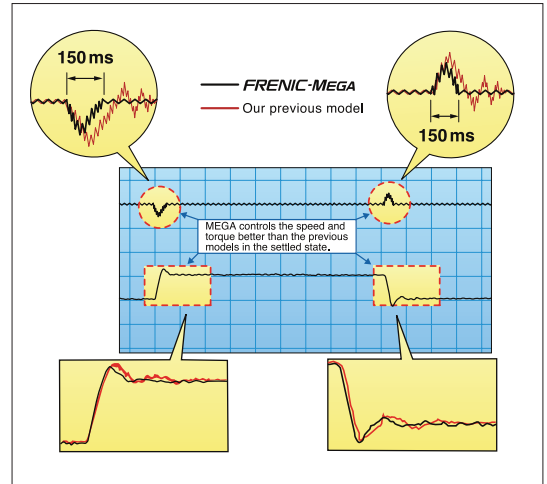

### Double rating

#### HD (High Duty) Specification

- Overload capacity 150% 1 min 200% 3 sec
- Inverter capacity = Motor capacity
- General use

#### LD (Low Duty) Specification

- Overload capacity 120% 1 min
- The motor capacity can be one size larger than the inverter capacity
- For applications with light loads (fans, pumps or centrifugal machines)

## Support for simple maintenance and improved working efficiency

### Basic keypad TP-E1U



Basic keypad TP-E1U

- Built-in USB port (mini B connector): allows easy connection of a personal computer equipped with loader software.
- Able to save:
  - ◆ 1 complete function data set
  - ◆ Inverter operation data
- When this keypad is connected to the inverter, all loader software features can be used:
  - ◆ Editing, comparing, copying the function code data
  - ◆ Real time operation monitor
  - ◆ Alarm history (indicating the latest 4 alarms)
  - ◆ Maintenance information
  - ◆ Real time trace
  - ◆ Historical trace

Can be disconnected from the inverter and used standalone, connecting the keypad to a personal computer equipped with loader software (using USB connection). Allows to check the data saved in the keypad away from the factory site (office).

### Multifunctional keypad TP-G1-J1



Multifunctional keypad TP-G1-J1

- LED and LCD display
- Function description in clear text (multi languages)
- Able to save 3 complete function sets
- Compatible with FRENIC-Eco and FRENIC-Multi
- Menu 0 can be defined
- I/O Check menu
- Operation monitor menu
- Communications debug menu

# Wiring diagram

3 analog inputs:  
 1:  $\pm 10$  VDC  
 2:  $\pm 10$  VDC  
 3: 4-20 mA/PTC

For further information about connecting the motor cable shield, please refer to FRENIC-MEGA Instruction Manual, Chapter 9.3 "Compliance with EMC Standards".

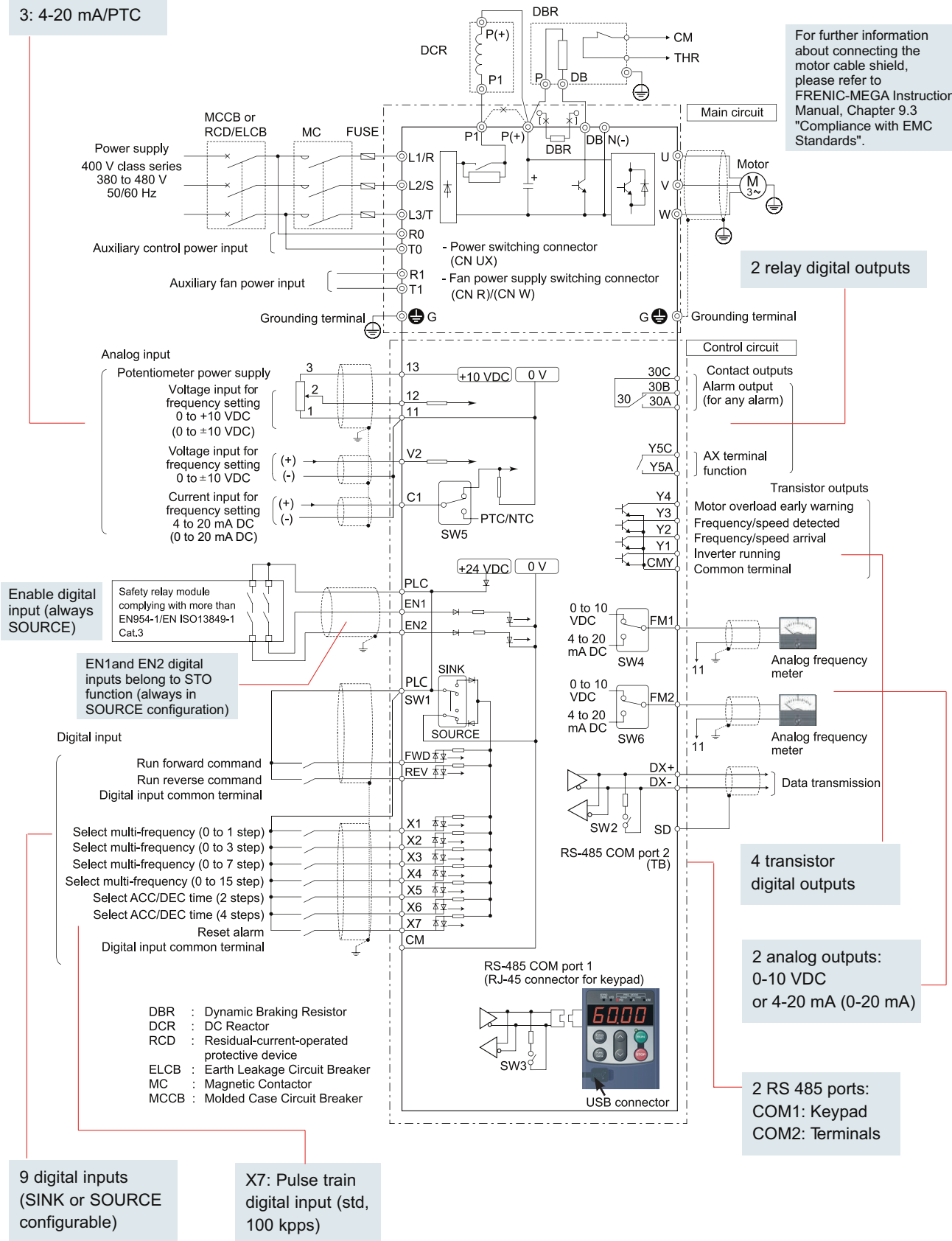

## Longer life design

### Designed life 10 years

The designed life of the various consumable parts inside the inverter has been extended to 10 years. This reduces maintenance downtime.

- Main circuit capacitor: 10 years
- Electrolytic capacitor on PCB: 10 years
- Cooling fan: 10 years

The part's life is estimated on the condition that the inverter is used at an ambient air temperature of 40°C and under the load rate of 100% (HD spec) or 80% (LD spec).

### Full support of life warnings

- The inverter is loaded with the functions for facilitating the maintenance of the equipment.

## Consideration for environment

### Enhanced resistance to environmental impact

Resistance to the environmental impact has been enhanced compared with conventional inverters.

- Enhanced durability of the cooling fan, reducing environmental impact
- Adoption of copper bars plated with nickel (Ni) or tin (Sn)

## 4 complete motor maps

Each motor (1-4) can be configured by its own function group, and the control mode for each motor (1-4) can be selected independently. Each motor can also be tuned independently.

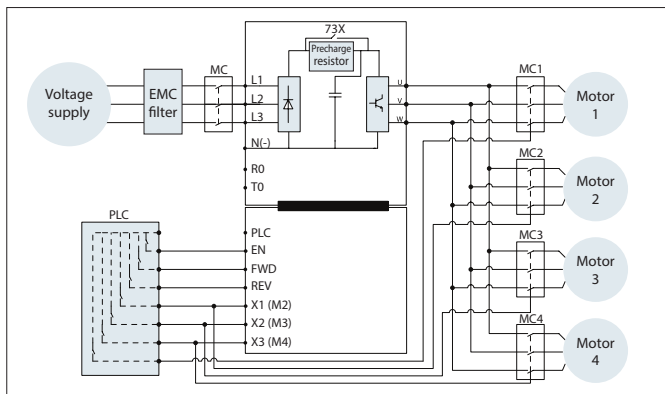

## Servo lock function

- The inverter holds the position of the motor shaft
- Only available when using speed feedback (closed loop)
- To activate servo lock function, a digital input programmed with (LOCK) must be active
- The inverter can indicate servo lock completion by a digital output programmed with (PSET) function

## Complete PID control functions

### 1. Unbalanced, bumpless function

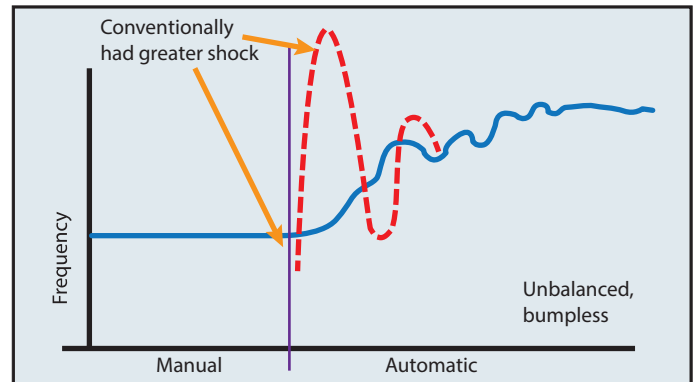

### 2. Anti-reset windup function has been added

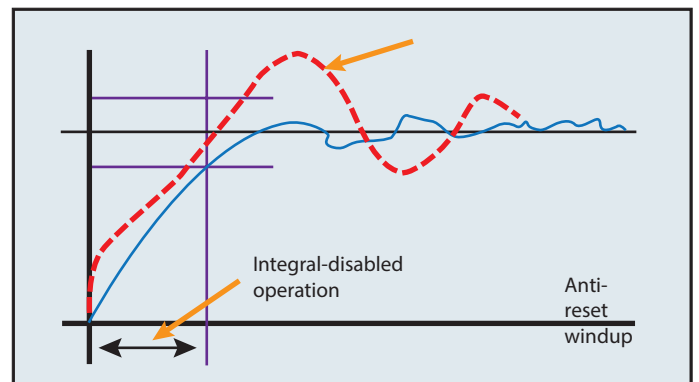

### 3. Stops operation at a slow flow rate

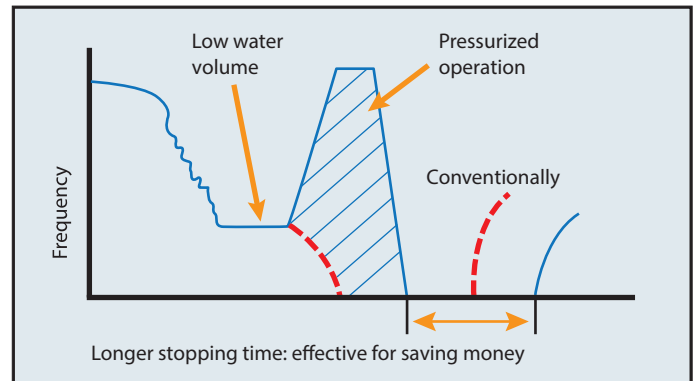

## Loader Software

- Efficient data management: editing, comparing, copying function code data
- Test run, motor auto-tuning: aid at startup
- Operation monitor, real-time and historical tracing, failure monitor, multi-monitor: aid for maintenance and defect analysis
- Operation on Windows 2000, XP, Vista, Windows 7, 8 and 10

## Fieldbus options

- ProfiBus DP interface
- CC-Link interface
- CANopen interface
- Profinet IO
- DeviceNet interface
- Modbus/TCP, EtherNet/IP, BACnet/IP,
- T-Link interface
- Allen Bradley CSP
- SX Bus interface



# Specifications 3-phase 400 V series

Item		Specifications															
Type (FRN□□□G1E-4E)		0.4	0.75	1.5	2.2	4.0	5.5	7.5	11	15	18.5	22	30	37	45	55	
Nominal applied motor [kW] <sup>1</sup> HD		0.4	0.75	1.5	2.2	4.0	5.5	7.5	11	15	18.5	22	30	37	45	55	
Nominal applied motor [kW] <sup>1</sup> LD		-	-	-	-	-	7.5	11	15	18.5	22	30	37	45	55	75	
Output ratings	Rated capacity [kVA] <sup>2</sup>	1.1	1.9	2.8	4.1	6.8	10	14	18	24	29	34	45	57	69	85	
	Rated voltage [V] <sup>3</sup>	3-phase 380 to 480 V (with AVR)															
	Rated current [VA] HD	1.5	2.5	4	5.5	9	13.5	18.5	24.5	32	39	45	60	75	91	112	
	Rated current [VA] LD	-	-	-	-	-	16.5	23	30.5	37	45	60	75	91	112	150	
	Overload capability	150% for 1 min, 200% for 3.0 s (HD) / 120% for 1 min (LD)															
Input ratings	Main circuit power (Phases, voltage, frequency)	3-phase 380 to 480 V, 50 / 60 Hz															
	Auxiliary control power input (Phases, voltage, frequency)	Single-phase 380 to 480 V, 50 / 60 Hz															
	Auxiliary power input for fan (Phases, voltage, frequency) <sup>4</sup>	-															
	Voltage, frequency variations	Voltage: +10 to -15% (Voltage unbalance: 2% or less <sup>5</sup> ), Frequency: +5 to -5%															
	Rated current [A] <sup>6</sup> HD	with DCR	0.85	1.6	3.0	4.5	7.5	10.6	14.4	21.1	28.8	35.5	42.2	57.0	68.5	83.2	102
		without DCR	1.7	3.1	5.9	8.2	13.0	17.3	23.2	33	43.8	52.3	60.6	77.9	94.3	114	140
	Required power supply capacity [kVA] <sup>7</sup> HD	with DCR	0.6	1.2	2.1	3.2	5.2	7.4	10	15	20	25	30	40	48	58	71
without DCR		-	-	-	-	-	14.4	21.1	28.8	35.5	42.2	57	68.5	83.2	102	138	
Rated current [A] <sup>6</sup> LD	with DCR	-	-	-	-	-	23.2	33.0	43.8	52.3	60.6	77.9	94.3	114	140	-	
	without DCR	-	-	-	-	-	10	15	20	25	30	40	48	58	71	96	
Braking	Torque [%] <sup>8</sup>	150%			100%				20%				10 to 15%				
	Braking transistor	Built-in															
	Min. ohmic value [Ω] / Torque [%]	200 / 180%		160 / 180%		96/180%		64/180%		48/180%		32/180%		24/180%		16 / 180%	
	Built-in braking resistance	720 Ω	470 Ω	160 Ω				80 Ω				-					
	Braking time [s]	5s															
		%ED	5	3	5	3	2	3	2	-							
	DC injection braking	Starting frequency: 0.0 to 60.0 Hz, braking time: 0.0 to 30.0 s, braking level: 0 to 100%															
EMC filter	EMC standard compliance: Category C3 is only emission and 2nd env. is immunity (EN61800-3:2004)																
DC reactor (DCR)	Optional																
Applicable safety standards	UL508C, C22.2 No. 14, EN61800-5-1:2007, EN61800-5-2:2007 SIL2, EN ISO13849-1:2008 PL=d, Cat.3																
Enclosure (IEC60529)	IP20 (IEC60529) closed type, UL open type (UL 50)											IP00 open type, UL open type					
Cooling method	Natural cooling					Fan cooling											
Weight / mass [kg]	1.8	2.1	2.7	2.9	3.2	6.8	6.9	6.2	10.5	10.5	11.2	26	27	32	33		

Item		Specifications														
Type (FRN□□□G1E-4E)		75	90	110	132	160	200	220	280	315	355	400	500	630		
Nominal applied motor [kW] <sup>1</sup> HD		75	90	110	132	160	200	220	280	315	355	400	500	630		
Nominal applied motor [kW] <sup>1</sup> LD		90	110	132	160	200	220	280	315	355	400	500	630	710		
Output ratings	Rated capacity [kVA] <sup>2</sup>	114	134	160	192	231	287	316	396	445	495	563	731	891		
	Rated voltage [V] <sup>3</sup>	3-phase 380 to 480 V (with AVR)														
	Rated current [VA] HD	150	176	210	253	304	377	415	520	585	650	740	960	1170		
	Rated current [VA] LD	176	210	253	304	377	415	520	650	740	840	960	1170	1370		
	Overload capability	150% for 1 min, 200% for 3.0 s (HD) / 120% for 1 min (LD)														
Input ratings	Main circuit power (Phases, voltage, frequency)	3-phase 380 to 440 V / 50 Hz, 3-phase 380 to 480 V / 60 Hz														
	Auxiliary control power input (Phases, voltage, frequency)	Single-phase 380 to 480 V, 50 / 60 Hz														
	Auxiliary power input for fan (Phases, voltage, frequency) <sup>4</sup>	3-phase 380 to 440 V / 50 Hz, 3-phase 380 to 480 V / 60 Hz														
	Voltage, frequency variations	Voltage: +10 to -15% (Voltage unbalance: 2% or less <sup>5</sup> ), Frequency: +5 to -5%														
	Rated current [A] <sup>6</sup> HD	with DCR	138	164	201	238	286	357	390	500	559	628	705	881	1115	
		without DCR	-	-	-	-	-	-	-	-	-	-	-	-	-	
	Required power supply capacity [kVA] <sup>7</sup> HD	with DCR	96	114	140	165	199	248	271	347	388	436	489	611	773	
without DCR		-	-	-	-	-	-	-	-	-	-	-	-	-		
Rated current [A] <sup>6</sup> LD	with DCR	164	210	238	286	357	390	500	628	705	789	881	1115	1256		
	without DCR	-	-	-	-	-	-	-	-	-	-	-	-	-		
Required power supply capacity [kVA] <sup>7</sup> LD	with DCR	114	140	165	199	248	271	347	436	489	547	611	773	871		
	without DCR	-	-	-	-	-	-	-	-	-	-	-	-	-		
Braking	Torque [%] <sup>8</sup>	10 to 15%														
	Braking transistor	-														
	Min. ohmic value [Ω] / Torque [%]	-														
	DC injection braking	Starting frequency: 0.0 to 60.0 Hz, braking time: 0.0 to 30.0 s, braking level: 0 to 100%														
EMC filter	EMC standard compliance: Category C3 is only emission and 2nd env. is immunity (EN61800-3:2004)															
DC reactor (DCR)	Optional (must be installed)															
Applicable safety standards	UL508C, C22.2 No.14, EN61800-5-1:2007, EN61800-5-2:2007 SIL2, EN ISO13849-1:2008 PL=d, Cat.3															
Enclosure (IEC60529)	IP00 open type, UL open type															
Cooling method	Fan cooling															
Weight / mass [kg]	42	62	64	103	103	144	144	245	245	330	330	530	530			

1: Fuji Electric's 4-pole standard motor  
2: Rated capacity is calculated by assuming the output rated voltage as 200 V for 3-phase 200 V series and 440 V for 3-phase 400 V series.  
3: Output voltage cannot exceed the power supply voltage.  
4: The auxiliary power input is used as an AC fan power input when combining the unit such as high power factor PWM converter with power regenerative function (generally not used).  
5: Interphase voltage unbalance ratio [%] = (max. voltage [V] - min. voltage [V]) / 3-phase average voltage [V] x 67 (see IEC61800-3).  
6: The value is calculated on assumption that the inverter is connected with a power supply capacity of 500 kVA (or 10 times the inverter capacity if the inverter capacity exceeds 50 kVA) and %X is 5%.  
7: Obtained when a DC reactor (DCR) is used.  
8: Average braking torque obtained by use of a motor (varies with the efficiency of the motor).

**Headquarters Europe (Germany)**

Fuji Electric Europe GmbH  
Goethering 58  
63067 Offenbach/Main  
Germany  
Tel. : +49 69 66 90 29 0  
Fax : +49 69 66 90 29 58  
info.inverter@fujielectric-europe.com  
www.fujielectric-europe.com

**Spain**

Fuji Electric Europe GmbH  
C/ dels Paletes 8, Edifici B, Planta 1, Oficina B  
Parc Tecnològic del Vallès  
08290 Cerdanyola del Vallès (Barcelona)  
Spain  
Tel. : +34 93 5824333  
Fax : +34 93 5824344  
info.spain@fujielectric-europe.com  
www.fujielectric-europe.com

**Italy**

Fuji Electric Europe GmbH  
Via Rizzotto 46  
41126 Modena (MO)  
Italy  
Tel. : +39 059 47 34 266  
Fax : +39 059 47 34 294  
info.italy@fujielectric-europe.com  
www.fujielectric-europe.com

**France**

Fuji Electric Europe GmbH  
265 Rue Denis Papin  
38090 Villefontaine  
France  
Tel. : +33 4 74 90 91 24  
Fax : +33 4 74 90 91 75  
info.france@fujielectric-europe.com  
www.fujielectric-europe.com

**Switzerland**

Fuji Electric Europe GmbH  
Park Altenrhein  
9423 Altenrhein  
Switzerland  
Tel. : +41 71 858 29 49  
Fax : +41 71 858 29 40  
info.swiss@fujielectric-europe.com  
www.fujielectric-europe.com

**UK**

Fuji Electric Europe GmbH  
Tel. : +44 7 989 090 783  
info.uk@fujielectric-europe.com  
www.fujielectric-europe.com