

INDUSTRIAL VIBRATORS

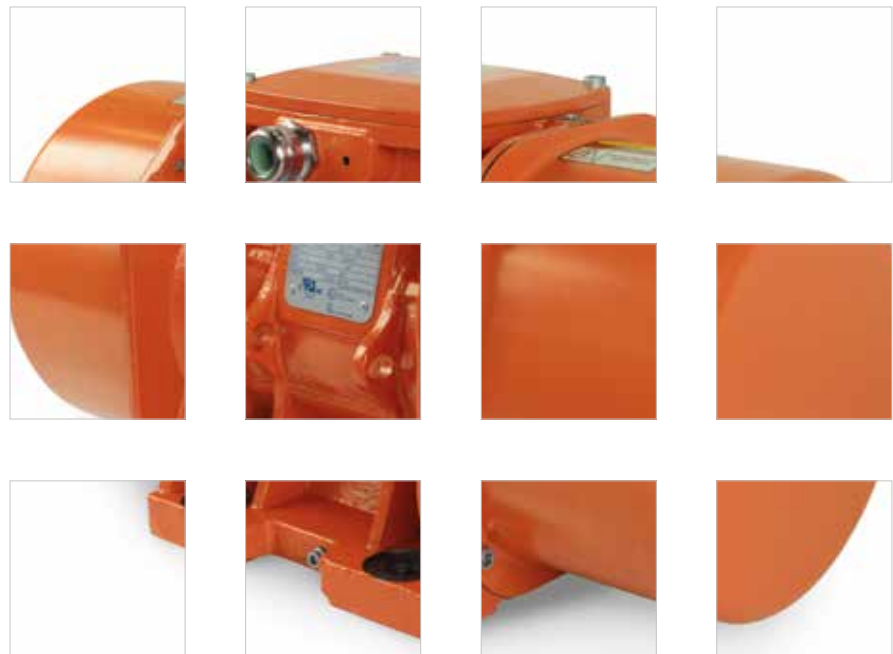

THE WORLDWIDE LEADER IN VIBRATION TECHNOLOGY

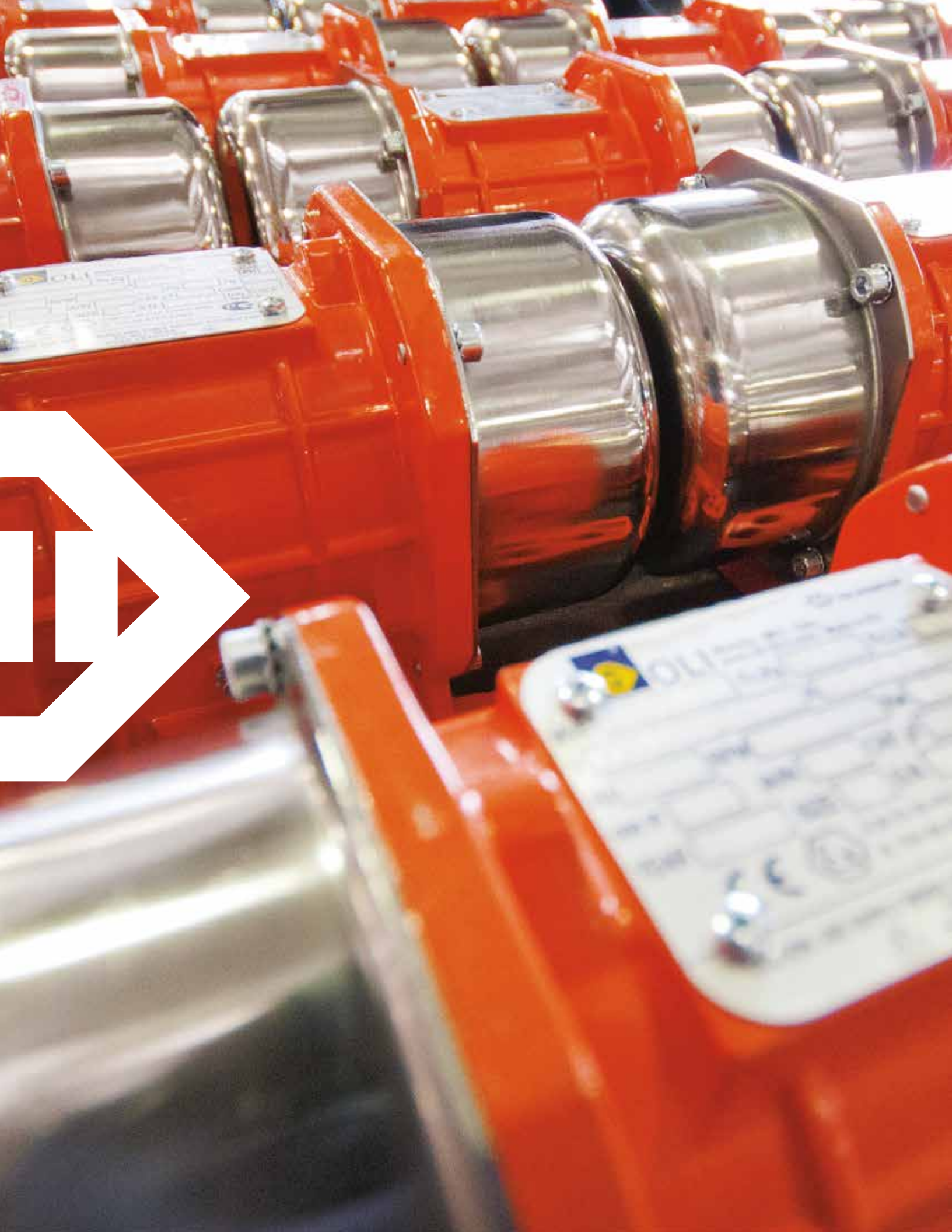





Intro

Company profile	4
Technical features	6
Standard specifications	7
The OLI vibrator range	8
Certifications	9
How to choose a motovibrator	10

MVE Standard Range

2 poles	12
4 poles	14
6 poles	16
8 poles	18
2 poles single phase	20
MICRO	22
MVE DC Direct Current	24

MVE-Exd Explosion-Proof

2 and 4 poles	26
6 and 8 poles	28

MVE-Milling Grain Purifier

8 and 10 poles	30
----------------	----

MVE-SV Screen Vibrator

4 poles	32
---------	----

MVE-SS Stainless Steel

4, 6, 8 poles	34
---------------	----

Installation

Mounting	36
How to change vibration intensity	38

Technical drawings

Drawings	extra page
----------	------------



Worldwide leader in vibration technology

OLI is **the world's top selling manufacturer of Electric and Pneumatic Vibrators**. A high level of customer service is guaranteed through 18 OLI Trading Subsidiaries, 36+ local warehouses and 3 manufacturing plants worldwide.

OUR 3 DIVISIONS

PROVIDE CUSTOMERS WITH OPTIMAL SOLUTIONS FOR ALL REQUIREMENTS

INDUSTRIAL VIBRATORS



Electric motovibrators for vibrating equipment

FLOW AIDS



Comprehensive range of electric and pneumatic vibrators to solve any problem of flowability

CONCRETE CONSOLIDATION



Internal concrete vibrators and converters for reliable and efficient concrete compaction



Originally specializing in immersion vibrators for concrete consolidation, OLI is now the worldwide leader in vibration technology, with a **complete range of electric and pneumatic internal and external vibrators.**

By supplying **competitive, high quality products for wide-ranging applications,** OLI combines **performance** and **reliability** by adapting to the ever-changing market. A strong believer in innovation, OLI is constantly striving to be ahead of the opposition.

As a global player in industrial vibration technology, the key focus of OLI's business strategy is **rapid stock delivery, any time, anywhere in the world.**

Excellent customer service is of pivotal importance: the company guarantees **quick order processing** and customers worldwide can enjoy access to the same high quality product and services.

OLI has access to credible expertise when it comes to finding suitable solutions to customers' requests. A team of engineers specialized in designing efficient, reliable and safe solutions backed by a **globally certified management.**

OLI provide their customers with state-of-the-art equipment and the blueprint for the next generation of products is already in progress.



TECHNICAL FEATURES

QUALITY



- World class materials
- Class F insulation
- Durable sealing
- Premium bearings
- Strong body design - FEM designed
- Vacuum insulation
- FMEA analysis
- 3D quality check

EFFICIENCY

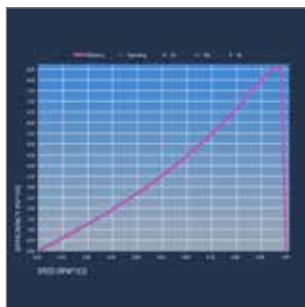

- Optimized power/weight ratio
- S1 continuous duty service
- Optimized electric design

RELIABILITY



- PTC thermistor 130 °C
- Specific grease retaining device
- Tropicalized standard
- IP66 protection
- Class F insulation

FLEXIBILITY

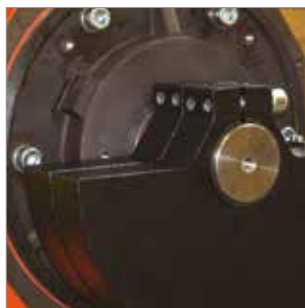

- Easy mass adjustment
- Various voltages and frequencies available
- Easy access to the terminal box
- Multiple eye-bolts



Standard specifications

Specification	RANGE					
	Standard	Increased Safety	Explosion-Proof	Hi-stroke Milling	Screen Vibrator	Stainless Steel
Power supply	Three-phase from 24V to 690V. 50Hz or 60Hz; Single phase 110V 60Hz and 220V 50Hz. Three-phase motors are designed for inverter application.	Three-phase from 230V to 500V. 50Hz or 60Hz. All motors are designed for inverter application from 20Hz to base frequency.	Three-phase from 230V to 690V. 50Hz or 60Hz. All motors are designed for inverter application from 20Hz to base frequency.		Three-phase from 220V to 690V. 50Hz or 60Hz.	
Time rating	Continuous duty (S1)					
Protection structure	Mechanical protection IP66 according to IEC 60529					
Bearings	Ball bearings from size MICRO to 50. Roller bearings from size 60 to 110.	Ball bearings from size 10 to 50. Roller bearings from size 60 to 90.	Roller bearings			Ball bearings from size 10 to 50
Coating colour	Polyester powder coating. Standard colour RAL 2009. Special corrosion resistant painting available on request on Standard range only.					AISI 316 frame not painted
Footprint	Compatibility with the main competitor's footprint on request.					/
Installation and operating environment	For indoor and outdoor use.					
	Ambient temperature: -20 °C to +40 °C Up to +55 °C available on request	Ambient temperature: -20 °C to +40 °C	Ambient temperature: -20 °C to +40 °C Up to +60 °C available on request	Ambient temperature: -20 °C to +40 °C	Ambient temperature: -20 °C to +40 °C.	Ambient temperature: -20 °C to +40 °C
Standards supported	Conformity with European Directive Low voltage 2014/35/UE Machine directive 2006/42/EC ATEX 2014/34/UE					
Mass covers	Aluminium for motors from size 10 to size 50 and size 100, 105, 110. Mild steel for size 60 to size 91. Stainless steel AISI 304 for direct current motovibrators.	Aluminium for motors from size 10 to size 50. Mild Steel for size 60 to size 91.	AISI 304 Stainless Steel	Mild Steel	Aluminium	AISI 304 Stainless Steel
Windings	2, 4, 6 and 8 poles three-phase asynchronous motor from size 10 to 110. 2 poles single phase from size 10 to 30.	2, 4, 6 and 8 poles three-phase asynchronous motor		8 and 10 poles three-phase asynchronous motor	4 poles	4, 6 and 8 poles three-phase asynchronous motor
	Class F insulating materials (155 °C). Vacuum impregnated windings. PTC thermistor 130 °C standard from size 60.					Class F insulating materials (155 °C). Vacuum impregnated windings.
Flanges	Grey cast iron up to size 80. Ductile cast iron from size 100.				Ductile cast iron	AISI 316
Frame	Aluminium up to size 50. Ductile cast iron from size 60.				Aluminium	AISI 316
Shaft	Steel alloy highly resistant.					
Eccentric masses	Completely adjustable.					



The OLI Vibrator Range

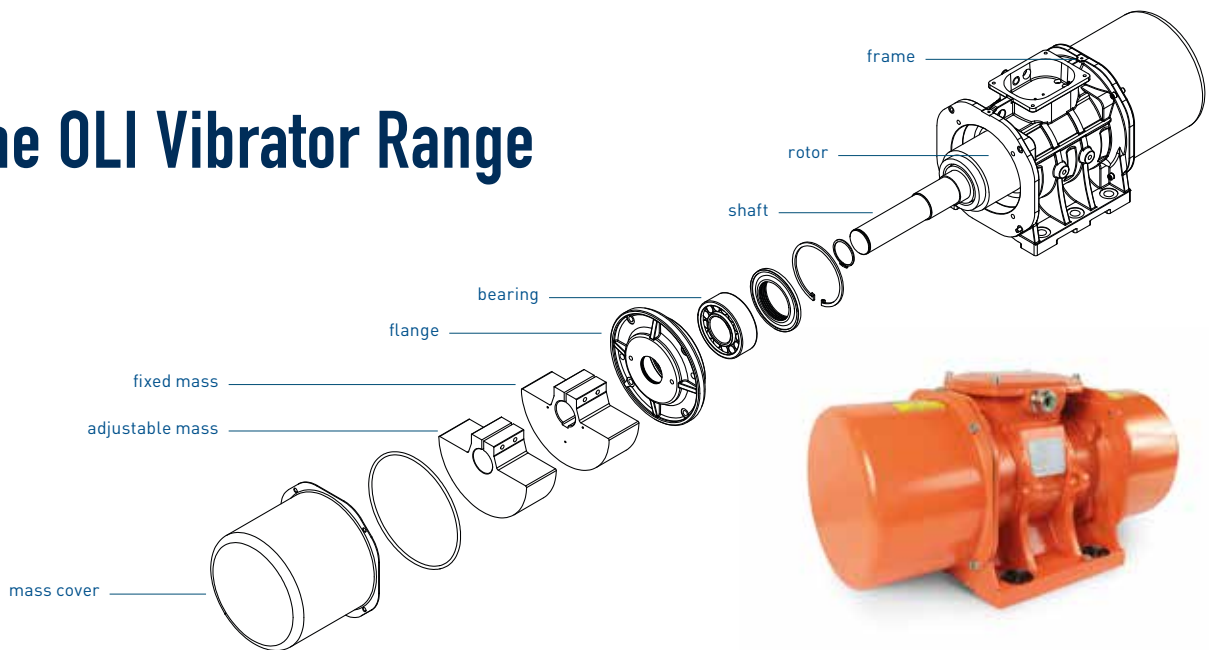

Providing centrifugal force up to 59,000 lbs and with multiple voltage options OLI's range of electric motovibrators covers several fields of application in every country as well as many different industrial sectors: from food to mining, from foundry to recycling and more.

OLI's electric motovibrators are designed and manufactured using the latest technologies and premium quality materials and components.

Motor bodies, bearing flanges and shafts are FMEA designed and manufactured using first grade Aluminium alloy, cast iron and steel alloy to withstand heavy duty applications and

guarantee safe operation in any condition.

Vacuum impregnated windings and class F insulating materials enhance reliability and durability.

Top quality bearings and an efficient grease retaining system assure long lasting performance and low noise generation.

Adjustable eccentric masses allow easy fine tuning of the Max centrifugal force provided by the motor.

Several certifications for use in hazardous environments are available in the OLI range to match the most demanding specification worldwide.

ATEX ZONES

- ACCIDENTAL RISK
- OCCASIONAL RISK
- CONSTANT RISK

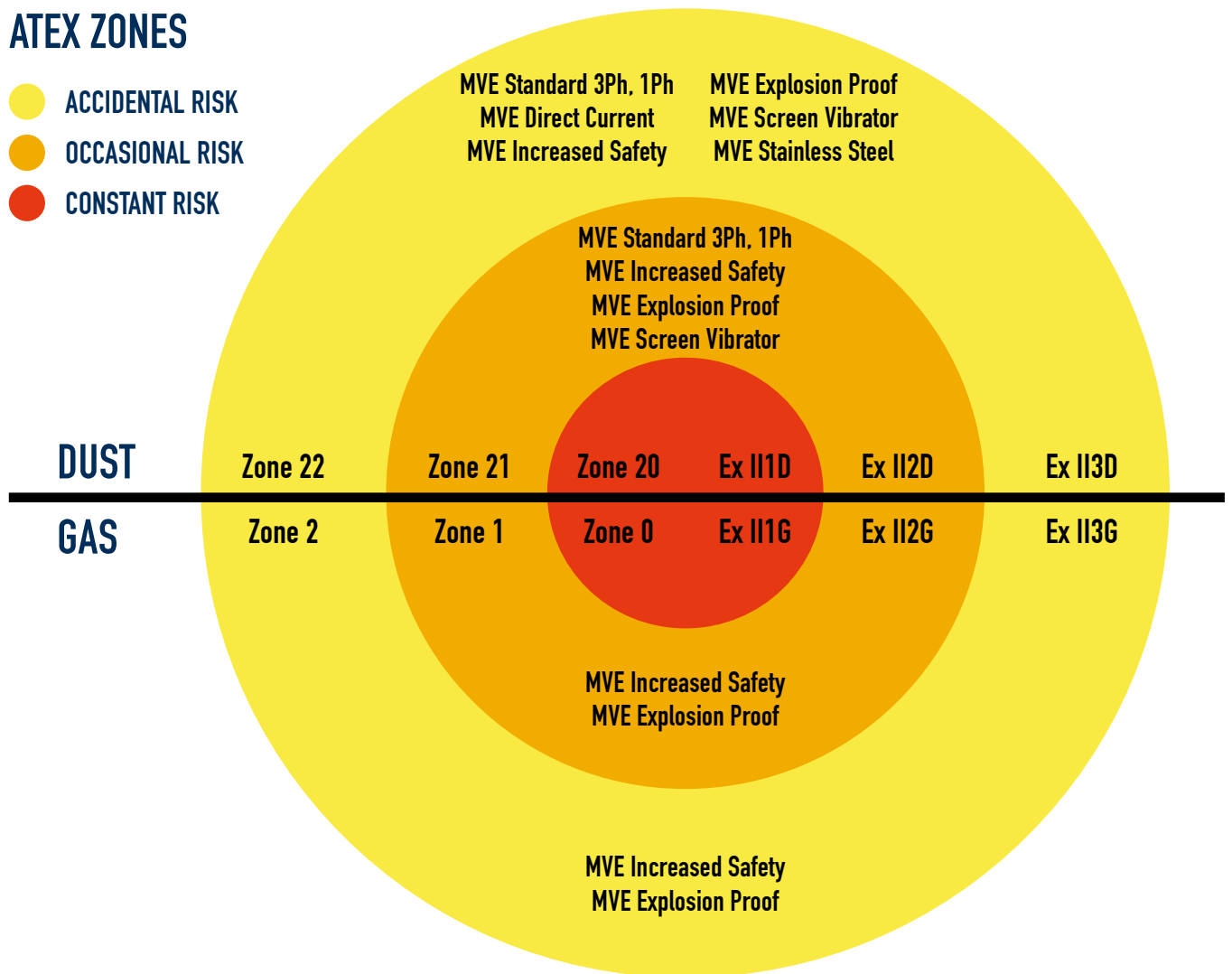



Certifications

Standard range

SIZE 10-91

SIZE 100, 105, 110

MICRO

1-PH



Conformity with European Directive - Low voltage 2014/35/UE; Machine Directive 2006/42/EC; ATEX 2014/34/UE - UL 1836. UL 1004-1 - SAC22.2 NO 25. 100. 145

CATEGORY	CERTIFICATIONS	INTERNATIONAL STANDARD	GAS	DUST
ATEX zone 21 Class II Div.2 Temperature range -20/+40 °C *		EN 60079-0, EN 60079-31	n/a	II2D Ex tb IIIC Tx Db IP66
		IEC 60079-0, IEC 60079-31	n/a	Ex tb IIIC Tx Db IP66
		UL 1004-1, UL 60079-0, UL 60079-31 CSA 22.2 100, CSA 22.2 60079-0, CSA 22.2 60079-31	n/a	Class II Div.2 Groups F, G T4

* Extended temperature range up to 55 °C available on request.

MVE DC Range: II3D Ex tc IIIC T100 IP66

Tx = T100 °C up to size 30 included;
Tx= T135 °C from size 40 up.

Screen vibrator and Stainless Steel range

SIZE 30-60



Conformity with European Directive - Low voltage 2014/35/UE; Machine Directive 2006/42/EC; ATEX 2014/34/UE

CATEGORY	CERTIFICATIONS	INTERNATIONAL STANDARD	GAS	DUST
ATEX zone 22 Temperature range -20/+40 °C *		EN 60079-0, EN 60079-31	n/a	II3D Ex tc IIIC T100 IP66
		UL 1446, CSA C22.2 NO 0-10	n/a	n/a

Explosion proof

SIZE 50-80



Conformity with European Directive - Low voltage 2014/35/UE; Machine Directive 2006/42/EC - ATEX 94/9/EC - UL 1836. UL 1004-1. UL 674 - CSAC22.2 NO 25. 100. 145

CATEGORY	CERTIFICATIONS	INTERNATIONAL STANDARD	GAS	DUST
ATEX zone 1-21 Class II Div.1		EN 60079-0, EN 60079-31, EN 60079-1	ATEX II 2 G Ex db IIB T4	II2 D Ex tb IIIC IP66 Tx
		IEC 60079-0, IEC 60079-31, IEC 60079-1	IECEx II 2 G Ex db IIB T4	II2 D Ex tb IIIC IP66 Tx
		UL 1004-1, UL 674 CSA 22.2 100, CSA 22.2 25, CSA 22.2 145, CSA 22.2 60079-1, CSA 22.2 60079-0, CSA 22.2 60079-31	CLASS I Div.1 Group C, D T4 IP66	n/a



How to choose a motovibrator

1.

Choose rpm and the amplitude "e" (0 - peak) suitable for your application:

Circular vibration

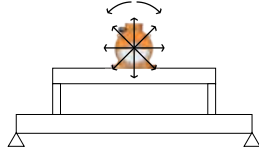

Linear vibration

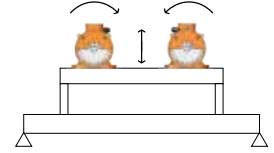

Application processes	Vibration		Revolutions Per Minute						
			50Hz	750	1000	1500	3000	6000	
	Circular	Linear	60Hz	900	1200	1800	3600	-	
Conveying		✓			✓	✓			
Separation / Screening / Sizing		✓		✓	✓	✓			
Positioning / Feeding		✓		✓	✓	✓			
Filter cleaning	✓						✓		
Silo/hopper emptying	✓						✓		
Fluid beds		✓		✓	✓				
Bin activators	✓					✓	✓		
Compacting		✓					✓	✓	
Concrete consolidation	✓						✓	✓	

rpm	e (mm)	
	Min.	Max.
3,600	0.3	0.6
3,000	0.3	0.8
1,800	1.2	2.2
1,500	1.4	2.6
1,200	2.5	4.0
1,000	3.0	5.2
900	3.5	5.5
750	3.5	6.0

2.

Choose an MVE from the tables of the following pages and use its Wm into this formula:

$$e = \frac{n \times UW}{n \times M_{mot} + M_{vm}}$$

e = amplitude of vibration 0-peak (in)

n = number of vibrating motors

UW = Unbalanced (inlbs)

M_{mot} = motor weight (lbs)

M_{vm} = vibrating machine weight (without material and motors)

3.

Check the obtained value “e”:

- If it is similar to the required one (step 1) ➔ the MVE model is correct.
- If it is not similar to the required one (step 1) ➔ repeat the process (step 2) with a different MVE model.

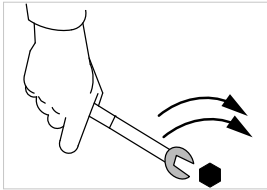

For tips on installation see section page 40



Important

Several voltages are available to match local electric specifications worldwide both at 50Hz and 60Hz.

All OLI motors can be operated with double voltage by simply changing the connections inside the terminal box from Star to Delta or vice-versa.

Three-phase MVEs with double rated voltage:

Λ (Star) High Voltage - Factory preset

Δ (Delta) Low Voltage

MVEs with “(Delta)”:

Δ (Delta) Low Voltage - Factory preset

Λ (Star) High Voltage

For details about “Star” and “Delta” connections see page 41.

VOLTAGE Delta / Star	Frequency (Hz)	Country
200-230 / 345-400	50 / 60	Japan and Saudi Arabia
220-240 / 380-415	50	Europe and most of Asian Countries
230 / 460 *	60	USA
330 / 575 *	60	Canada
220-277 / 380-480	60	Brazil
290-300 / 500-525	50	South Africa
500-525 (Delta)	50	South Africa
380-480 (Delta)	60	Brazil
575 (Delta) *	60	Canada
380-415 / 660-720 (Delta)	50	Europe and most of Asian Countries
460 (Delta) *	60	USA
115 (Single-phase)	60	USA and Canada
115 (Single-phase)	50	Variuous
220 (Single-phase)	60	Brazil
230 (Single-phase)	50	Europe and most of Asian Countries

*** Voltage Tolerance: ± 10%**



MVE STANDARD RANGE

2 POLES – 3000/3600 rpm



Unbalance (inlb)		Model	Centrifugal Force (lb)		Weight (lb)		ELECTRICAL SPECIFICATIONS						CERTIFICATE		
			50Hz	60Hz	50Hz	60Hz	Input Power (Hp)		Nominal Current A max. (Y)		Ia/In		Cable Gland	Class II Div.2	II 2D
50Hz	60Hz	60Hz	50Hz	60Hz	50Hz	60Hz	50Hz	60Hz	50Hz (400V)	60Hz (460V)	50Hz	60Hz	Metric	Temp. Class	Temp. Class
0.57	0.43	MVE 160/2E-10A0	146	157	9		0.12	0.12	0.25	0.23	3.2	3.2	M16	T4	100 °C
0.85	0.57	MVE 220/2E-10A0	216	209	11		0.12	0.12	0.25	0.23	3.2	3.2	M16	T4	100 °C
1.61	1.13	MVE 440/2E-20A0	412	417	15		0.20	0.24	0.35	0.30	3.5	3.5	M20	T4	100 °C
1.61	1.13	MVE 440/2E-23A0	412	417	16		0.20	0.24	0.35	0.30	3.5	3.5	M20	T4	100 °C
2.77	1.94	MVE 690/2E-30A0	708	712	22		0.34	0.38	0.52	0.45	3.8	3.7	M20	T4	100 °C
3.45	2.47	MVE 890/2E-30A0	897	906	23		0.36	0.44	0.58	0.60	3.7	3.7	M20	T4	100 °C
4.46	3.20	MVE 1200/2E-40A0	1,168	1,177	35		0.67	0.78	0.96	0.97	4.2	4.4	M20	T4	135 °C
6.47	4.59	MVE 1700/2E-40A0	1,671	1,687	36		0.79	0.82	1.25	1.24	4.5	5.2	M20	T4	135 °C
6.81	4.80	MVE 1800/2E-50A0	1,750	1,764	45		0.94	1.13	1.45	1.50	4.0	4.0	M20	T4	135 °C
8.79	6.08	MVE 2300/2E-50A0	2,216	2,233	47		1.27	1.54	1.85	1.95	4.6	4.7	M20	T4	135 °C
11.54	8.07	MVE 3100/2E-50A0	2,987	3,009	48		1.74	1.85	2.44	2.25	5.4	5.2	M20	T4	135 °C
11.54	8.07	MVE 3100/2E-51A0	2,987	3,009	48		1.74	1.85	2.44	2.25	5.4	5.2	M20	T4	135 °C
13.57	9.64	MVE 3500/2E-60A0	3,530	3,545	112	109	2.07	2.15	2.94	2.61	6.1	6.4	M25	T4	135 °C
15.96	11.98	MVE 4100/2E-60A0	4,469	4,403	114	111	2.82	2.82	3.75	3.42	6.7	6.6	M25	T4	135 °C
19.95	13.83	MVE 5100/2E-60A0	5,075	5,084	116	112	3.22	3.29	4.44	3.45	6.2	6.5	M25	T4	135 °C
29.56	19.05	MVE 7600/2E-75A1	7,169	7,002	227	224	3.70	3.89	5.30	4.61	8.5	8.4	M32	T4	135 °C
34.46	24.30	MVE 8800/2E-75A1	8,891	8,933	236	229	3.89	3.89	5.30	4.61	8.7	9.9	M32	T4	135 °C
44.81	30.28	MVE 11500/2E-75A1	11,043	11,129	245	233	5.36	5.36	7.22	6.28	8.7	10.0	M32	T4	135 °C
										A max. (Δ)					
56.23	39.30	MVE 14400/2E-85A0	14,352	14,445	504	506	7.01	7.38	9.43	8.20	8.7	9.0	M32	T4	135 °C
77.95	56.23	MVE 20100/2E-85A0	19,897	20,668	530	517	12.74	12.47	17.80	14.40	8.6	8.8	M32	T4	135 °C
56.23	39.30	MVE 14400/2E-86A0	14,352	14,445	504	506	7.38	8.45	9.50	9.50	8.2	7.7	M32	T4	135 °C
77.95	56.23	MVE 20100/2E-86A0	19,897	20,668	530	517	8.85	10.33	11.50	11.50	8.2	8.2	M32	T4	135 °C



UP TO SIZE 60 (NOT INCLUDED)
60Hz masses = 50Hz masses adjusted at 70%



ABOVE SIZE 60 (INCLUDED)
Specific masses for 60Hz



- » II2D Ex tb IIIC Tx Db IP66
- » Equipment and protective system intended for use in potentially explosive atmospheres (Zone 21) - Directive 2014/34/UE
- » Compliance with Essential Health and Safety Requirements
- » IEC 60034-1, IEC EN 60079-0, IEC EN 60079-31



		DIMENSIONAL SPECIFICATIONS (inches)															
Model	Drawing	Size	C		M		A	B	Ø G	Holes	D	E	F	H	I	L	N
			50Hz	60Hz	50Hz	60Hz				n°							
MVE 160/2E-10A0	A1	10A0	8.39		1.77		Multiple Footprint 2.44-2.91 4.17 0.35 1.30 3.27-4.02 0.28			4	5.12	5.31	0.41	1.97	3.78	4.21	3.35
MVE 220/2E-10A0	A1	10A0	8.39		1.77		Multiple Footprint 2.44-2.91 4.17 0.35 1.30 3.27-4.02 0.28			4	5.12	5.31	0.41	1.97	3.78	4.21	3.35
MVE 440/2E-20A0	B1	20A0	9.17		2.13		2.44-2.91	4.17	0.35	4	5.12	6.06	0.59	2.56	4.92	4.72	4.41
MVE 440/2E-23A0	G	23A0	8.74		2.17		Multiple Footprint 2.44-2.91 4.17 0.35 2.56 5.51 0.51 4.53 5.31 0.43 5.31 4.53 0.43			4	6.46	5.51	0.98	3.23	4.57	6.26	4.33
MVE 690/2E-30A0	C1	30A0	10.00		1.65		Multiple Footprint 3.15 4.33 0.43 3.54 4.92 0.51 4.88 4.33 0.43 5.31 4.53 0.43			4	5.91	6.81	0.59	3.11	5.91	6.54	5.28
MVE 890/2E-30A0	C1	30A0	10.79		2.05		Multiple Footprint 3.15 4.33 0.43 3.54 4.92 0.51 4.88 4.33 0.43 5.31 4.53 0.43			4	5.91	6.81	0.59	3.11	5.91	6.54	5.28
MVE 1200/2E-40A0	D1	40A0	12.99		3.07		4.13	5.51	0.51	4	6.69	7.72	0.59	3.62	6.65	6.54	6.22
MVE 1700/2E-40A0	D1	40A0	12.99		3.07		4.13	5.51	0.51	4	6.69	7.72	0.59	3.62	6.65	6.54	6.22
MVE 1800/2E-50A0	D1	50A0	12.64		2.44		4.72	6.69	0.67	4	8.19	8.27	0.87	3.78	7.28	7.56	6.69
MVE 2300/2E-50A0	D1	50A0	12.64		2.44		4.72	6.69	0.67	4	8.19	8.27	0.87	3.78	7.28	7.56	6.69
MVE 3100/2E-50A0	D1	50A0	12.64		2.44		4.72	6.69	0.67	4	8.19	8.27	0.87	3.78	7.28	7.56	6.69
MVE 3100/2E-51A0	D1	51A0	12.80		2.50		4.72	6.69	0.67	4	8.19	8.66	0.98	4.13	7.99	7.56	7.36
MVE 3500/2E-60A0	D1	60A0	15.83		3.54		5.51	7.48	0.67	4	9.06	10.24	1.02	4.88	9.45	8.58	8.74
MVE 4100/2E-60A0	D1	60A0	15.83		3.54		5.51	7.48	0.67	4	9.06	10.24	1.02	4.88	9.45	8.58	8.74
MVE 5100/2E-60A0	D1	60A0	15.83		3.54		5.51	7.48	0.67	4	9.06	10.24	1.02	4.88	9.45	8.58	8.74
MVE 7600/2E-75A1	D1	75A1	20.31		4.61		6.10	10.04	0.98	4	11.97	12.36	1.18	5.79	11.22	10.91	10.43
MVE 8800/2E-75A1	D1	75A1	20.31		4.61		6.10	10.04	0.98	4	11.97	12.36	1.18	5.79	11.22	10.91	10.43
MVE 11500/2E-75A1	D1	75A1	22.20	20.31	5.55	4.61	6.10	10.04	0.93	4	11.97	12.36	1.18	5.79	11.22	10.91	10.43
MVE 14400/2E-85A0	D1	85A0	24.57		5.12		7.87	12.60	1.10	4	15.16	15.83	1.57	7.99	15.51	14.17	14.88
MVE 20100/2E-85A0	D1	85A0	24.57		5.12		7.87	12.60	1.10	4	15.16	15.83	1.57	7.99	15.51	14.17	14.88
MVE 14400/2E-86A0	D1	86A0	24.57		5.12		7.87	12.60	1.10	4	15.16	15.83	1.57	7.99	15.51	14.17	14.88
MVE 20100/2E-86A0	D1	86A0	24.57		5.12		7.87	12.60	1.10	4	15.16	15.83	1.57	7.99	15.51	14.17	14.88

STANDARD

EXPLOSION-PROOF

MILLING

SCREEN VIBRATOR

STAINLESS STEEL

NOTE: Dimensions with coarse degree of accuracy related to UNI 22768/1

This information is provided without warranty, representation, inducement or licence of any kind. It is accurate to the best OLI knowledge or is obtained from sources believed to be accurate. OLI therefore assumes no legal responsibility. The latest and most updated information are available online.



» Class II Div.2 Group F, G T4
 » Conform to UL 1004-1, UL 1004-3, UL60079-31, UL60079-0, CSA 60079-0, CSA 60079- 31, CSA 22.2 N°100, CSA 22.2 N°77



MVE STANDARD RANGE

4 POLES - 1500/1800 rpm



Unbalance (inlb)		Model	Centrifugal Force (lb)		Weight (lb)		ELECTRICAL SPECIFICATIONS						CERTIFICATE		
			50Hz	60Hz	50Hz	60Hz	Input Power (Hp)		Nominal Current A max. (Y)		Ia/In		Cable Gland	Class II Div.2	II 2D
50Hz	60Hz	60 Hz	50Hz	60Hz	50Hz	60Hz	50Hz	60Hz	50Hz (400V)	60Hz (460V)	50Hz	60Hz	Metric	Temp. Class	Temp. Class
0.86	0.86	MVE 70/4E-10A0	55	79	10		0.07	0.05	0.31	0.31	2.2	2.2	M16	T4	100 °C
2.59	1.82	MVE 200/4E-20A0	165	168	16		0.09	1.13	0.31	0.25	2.2	2.2	M20	T4	100 °C
2.59	1.82	MVE 200/4E-23A0	165	168	16		0.09	1.13	0.31	0.25	2.2	2.2	M20	T4	100 °C
6.70	4.70	MVE 400/4E-30A0	428	432	26		0.16	0.19	0.49	0.50	2.2	2.2	M20	T4	100 °C
14.51	10.15	MVE 860/4E-40A0	926	933	43		0.36	0.43	0.84	0.86	2.7	2.7	M20	T4	135 °C
17.41	12.19	MVE 1150/4E-40AX	1,111	1,120	46		0.47	0.54	1.06	1.09	3.0	2.9	M20	T4	135 °C
11.54	8.07	MVE 750/4E-50A0	736	741	49		0.83	0.98	1.32	1.20	3.2	3.4	M20	T4	135 °C
11.54	8.07	MVE 750/4E-51A0	736	741	49		0.83	0.98	1.32	1.20	3.2	3.4	M20	T4	135 °C
24.67	17.08	MVE 1530/4E-50A0	1,574	1,570	60		0.83	0.98	1.32	1.20	3.2	3.4	M20	T4	135 °C
24.67	17.08	MVE 1540/4E-50A0	1,574	1,570	60		0.83	0.98	1.32	1.20	3.2	3.4	M20	T4	135 °C
32.81	22.96	MVE 2100/4E-50A0	2,094	2,110	73		0.86	1.03	1.40	1.35	4.2	4.2	M20	T4	135 °C
38.49	26.92	MVE 2300/4E-50A0	2,456	2,474	79	65	0.86	1.03	1.40	1.35	4.0	4.0	M20	T4	135 °C
38.06	26.64	MVE 2300/4E-51A0	2,429	2,447	77	63	0.86	1.03	1.40	1.35	4.0	4.0	M20	T4	135 °C
47.12	33.30	MVE 3100/4E-60A0	3,007	3,060	140	133	0.94	1.13	1.78	1.78	4.2	4.2	M25	T4	135 °C
59.59	39.92	MVE 3880/4E-60A0	3,803	3,668	149	141	1.52	1.74	2.16	2.09	4.9	4.7	M25	T4	135 °C
81.46	59.62	MVE 5340/4E-60A0	5,198	5,478	150	142	2.11	2.53	3.20	3.20	5.1	5.1	M25	T4	135 °C
88.34	58.87	MVE 5700/4E-70A0	5,637	5,410	184	164	2.36	2.68	3.08	3.00	6.2	6.3	M25	T4	135 °C
107.93	73.68	MVE 6840/4E-70A0	6,887	6,770	207	191	2.55	3.08	3.68	3.30	6.7	6.8	M25	T4	135 °C
133.11	88.86	MVE 8400/4E-75A0	8,494	8,166	276	249	2.95	3.49	4.15	4.15	7.0	7.0	M32	T4	135 °C
148.97	104.58	MVE 9480/4E-75A0	9,506	9,610	299	265	3.35	4.02	4.50	4.60	7.2	7.4	M32	T4	135 °C
189.84	131.83	MVE 12260/4E-80A0	12,114	12,114	399	373	3.86	4.63	6.50	5.50	7.3	7.2	M32	T4	135 °C
A max. (Δ)															
250.33	172.45	MVE 15850/4E-85A0	15,975	15,847	522	509	5.36	6.44	8.50	8.70	7.0	7.1	M32	T4	135 °C
311.62	216.47	MVE 19800/4E-85A0	19,885	19,892	556	531	9.86	11.40	13.40	12.00	7.2	7.2	M32	T4	135 °C
251.71	176.22	MVE 15850/4E-86A0	16,063	16,193	522	509	8.05	8.72	11.00	10.80	4.7	4.5	M32	T4	135 °C
314.59	220.05	MVE 19800/4E-86A0	20,075	20,221	556	531	8.05	8.72	11.00	10.80	4.7	4.5	M32	T4	135 °C
347.27	255.34	MVE 21000/4E-90A0	22,161	23,464	661	631	7.24	9.39	13.00	13.00	6.7	6.6	M32	T4	135 °C
362.71	252.32	MVE 21000/4E-91A0	23,146	23,186	661	631	9.39	11.00	13.10	13.10	7.2	7.7	M32	T4	135 °C
407.65	284.45	MVE 26100/4E-100A0	26,012	26,131	981	930	11.94	14.08	15.50	15.50	7.0	7.0	M32	T4	135 °C
495.85	363.55	MVE 33400/4E-100A0	31,640	33,406	1014	974	15.42	17.43	18.50	18.50	8.0	8.0	M32	T4	135 °C



UP TO SIZE 60 (NOT INCLUDED)
60Hz masses = 50Hz masses adjusted at 70%
Except for model MVE 1100/15 - 1100/18



ABOVE SIZE 60 (INCLUDED)
Specific masses for 60Hz



- » II2D Ex tb IIIC Tx Db IP66
- » Equipment and protective system intended for use in potentially explosive atmospheres (Zone 21) - Directive 2014/34/UE
- » Compliance with Essential Health and Safety Requirements
- » IEC 60034-1, IEC EN 60079-0, IEC EN 60079-31



		DIMENSIONAL SPECIFICATIONS (inches)															
Model	Drawing	Size	C		M		A	B	Ø G	Holes	D	E	F	H	I	L	N
			50Hz	60Hz	50Hz	60Hz				n°							
MVE 70/4E-10A0	A	10A0	8.39		1.77		Multiple Footprint 2.44-2.91 4.17 0.35 1.30 3.27-4.02 0.28			4	5.12	5.31	0.41	1.97	3.78	4.21	3.35
MVE 200/4E-20A0	B	20A0	9.17		2.13		2.44-2.91	4.17	0.35	4	5.12	6.06	0.59	2.56	4.92	4.72	4.41
MVE 200/4E-23A0	G	23A0	8.74		2.17		Multiple Footprint 2.44-2.91 4.17 0.35 2.56 5.51 0.51 4.53 5.31 0.43 5.31 4.53 0.43			4	6.46	5.51	0.98	3.23	4.57	6.26	4.33
MVE 400/4E-30A0	C	30A0	10.79		2.05		Multiple Footprint 3.15 4.33 0.43 3.54 4.92 0.51 4.88 4.33 0.43 5.31 4.53 0.43			4	5.91	6.81	0.59	3.11	5.91	6.54	5.28
MVE 860/4E-40A0	D1	40A0	12.99		3.07		4.13	5.51	0.51	4	6.69	7.72	0.79	3.62	6.85	6.54	6.30
MVE 1150/4E-40AX	D1	40A0	12.99		3.07		4.13	5.51	0.51	4	6.69	7.72	0.79	3.62	6.85	6.54	6.30
MVE 750/4E-50A0	D1	50A0	12.64		2.44		4.72	6.69	0.67	4	8.19	8.27	0.87	3.78	7.28	7.56	6.69
MVE 750/4E-51A0	D1	51A0	12.80		2.50		4.72	6.69	0.67	4	8.19	8.27	0.87	3.78	7.28	7.56	6.69
MVE 1530/4E-50A0	D1	50A0	15.39		3.82		4.72	6.69	0.67	4	8.19	8.27	0.87	3.78	7.28	7.56	6.69
MVE 1540/4E-50A0	D1	50A0	15.39		3.82		4.72	6.69	0.67	4	8.19	8.27	0.87	3.78	7.28	7.56	6.69
MVE 2100/4E-50A0	D1	50A0	17.91		5.08		4.72	6.69	0.67	4	8.19	8.27	0.87	3.78	7.28	7.56	6.69
MVE 2300/4E-50A0	D1	50A0	17.91	15.39	5.08	3.82	4.72	6.69	0.67	4	8.19	8.27	0.87	3.78	7.28	7.56	6.69
MVE 2300/4E-51A0	D1	51A0	16.30		4.17		4.72	6.69	0.67	4	8.19	8.66	0.98	4.13	7.95	7.56	7.36
MVE 3100/4E-60A0	D1	60A0	17.56		4.41		5.51	7.48	0.67	4	9.06	10.24	1.02	4.88	9.45	8.58	8.74
MVE 3880/4E-60A0	D1	60A0	17.56		4.41		5.51	7.48	0.67	4	9.06	10.24	1.02	4.88	9.45	8.58	8.74
MVE 5340/4E-60A0	D1	60A0	19.29	17.56	5.28	4.41	5.51	7.48	0.67	4	9.06	10.24	1.02	4.88	9.45	8.58	8.74
MVE 5700/4E-70A0	D1	70A0	19.72		4.84		6.10	8.86	0.87	4	10.83	11.42	1.18	5.51	10.08	9.84	9.29
MVE 6840/4E-70A0	D1	70A0	21.06	19.72	5.51	4.84	6.10	8.86	0.87	4	10.83	11.42	1.18	5.51	10.08	9.84	9.29
MVE 8400/4E-75A0	D1	75A0	22.20	21.10	5.94	4.61	6.10	10.04	0.93	4	11.97	12.36	1.18	5.79	11.22	10.91	10.43
MVE 9480/4E-75A0	D1	75A0	22.99	22.20	5.94	5.55	6.10	10.04	0.93	4	11.97	12.36	1.18	5.79	11.22	10.91	10.43
MVE 12260/4E-80A0	D1	80A0	23.74		5.63		7.09	11.02	1.02	4	13.07	14.17	1.46	6.57	13.58	11.97	12.20

MVE 15850/4E-85A0	D1	85A0	24.57		5.12		7.87	12.60	1.10	4	15.16	15.83	1.57	7.99	15.51	14.17	14.88
MVE 19800/4E-85A0	D1	85A0	24.57		5.12		7.87	12.60	1.10	4	15.16	15.83	1.57	7.99	15.51	14.17	14.88
MVE 15850/4E-86A0	D1	86A0	24.57		5.12		7.87	12.60	1.10	4	15.16	15.83	1.57	7.99	15.51	14.17	14.88
MVE 19800/4E-86A0	D1	86A0	24.57		5.12		7.87	12.60	1.10	4	15.16	15.83	1.57	7.99	15.51	14.17	14.88
MVE 21000/4E-90A0	E1	90A0	28.66		6.69		4.92	14.96	1.54	6	17.80	16.34	1.57	8.07	15.51	14.96	14.88
MVE 21000/4E-91A0	E1	91A0	28.66		6.69		4.92	14.96	1.54	6	17.80	16.34	1.57	8.07	15.51	14.96	14.88
MVE 26100/4E-100A0	E	100	35.04		8.27		5.51	17.32	1.77	6	20.87	19.06	1.46	9.13	17.56	18.50	16.69
MVE 33400/4E-100A0	E	100	35.04		8.27		5.51	17.32	1.77	6	20.87	19.06	1.46	9.13	17.56	18.50	16.69

NOTE: Dimensions with coarse degree of accuracy related to UNI 22768/1

This information is provided without warranty, representation, inducement or licence of any kind. It is accurate to the best OLI knowledge or is obtained from sources believed to be accurate. OLI therefore assumes no legal responsibility. The latest and most updated information are available online.



» Class II Div.2 Group F, G T4
 » Conform to UL 1004-1, UL 1004-3, UL60079-31, UL60079-0, CSA 60079-0, CSA 60079- 31, CSA 22.2 N°100, CSA 22.2 N°77

STANDARD

EXPLOSION-PROOF

MILLING

SCREEN VIBRATOR

STAINLESS STEEL



MVE STANDARD RANGE

6 POLES - 1000/1200 rpm



Unbalance (inlb)		Model	Centrifugal Force (lb)		Weight (lb)		ELECTRICAL SPECIFICATIONS						CERTIFICATE		
			50Hz	60Hz	50Hz	60Hz	Input Power (Hp)		Nominal Current A max. (Y)		Ia/In		Cable Gland	Class II Div.2	II 2D
50Hz	60Hz	60Hz	50Hz	60Hz	50Hz	60Hz	50Hz	60Hz	50Hz (400V)	60Hz (460V)	50Hz	60Hz	Metric	Temp. Class	Temp. Class
4.12	2.86	MVE 90/6E-30A0	117	117	23		0.16	0.19	0.30	0.40	2.2	2.2	M20	T4	100 °C
8.16	5.72	MVE 220/6E-30A0	231	234	24		0.16	0.19	0.30	0.40	2.2	2.2	M20	T4	100 °C
14.54	10.15	MVE 410/6E-40A0	412	414	41		0.20	0.24	0.65	0.63	2.2	2.2	M20	T4	135 °C
24.71	17.30	MVE 680/6E-50A0	701	705	58		0.34	0.40	0.67	0.64	2.7	2.7	M20	T4	135 °C
39.88	27.92	MVE 1100/6E-50A0	1,131	1,140	74		0.74	0.54	1.22	1.15	3.0	2.9	M20	T4	135 °C
39.88	39.88	MVE 1600/6E-50A0	1,131	1,629	75		0.74	0.54	1.20	1.15	3.0	2.9	M20	T4	135 °C
59.62	47.13	MVE 1730/6E-60A0	1,691	1,925	133	128	1.01	1.07	1.42	1.32	3.4	3.3	M25	T4	135 °C
81.46	59.59	MVE 2350/6E-60A0	2,310	2,434	172	158	1.01	1.07	1.42	1.32	3.4	3.3	M25	T4	135 °C
123.59	85.29	MVE 3090/6E-60A0	3,505	3,483	185	161	1.21	1.45	1.80	2.00	3.5	3.5	M25	T4	135 °C
130.05	88.31	MVE 3580/6E-70A0	3,688	3,607	199	175	1.21	1.45	2.40	2.30	3.9	3.8	M25	T4	135 °C
161.92	107.96	MVE 4740/6E-70A0	4,592	4,409	231	200	2.01	2.41	3.00	3.20	4.5	4.6	M25	T4	135 °C
174.04	119.46	MVE 4850/6E-70A0	4,936	4,879	235	205	2.01	2.41	3.00	3.20	4.5	4.6	M25	T4	135 °C
202.88	133.12	MVE 5690/6E-75A0	5,754	5,437	328	290	2.63	2.82	4.10	4.00	5.0	5.0	M32	T4	135 °C
234.52	164.80	MVE 6620/6E-75A0	6,651	6,731	343	304	2.95	3.22	4.50	4.30	5.2	5.2	M32	T4	135 °C
295.14	202.10	MVE 8160/6E-75A0	8,371	8,254	342	313	2.95	3.22	4.50	4.30	5.2	5.2	M32	T4	135 °C
295.30	189.85	MVE 8450/6E-80A0	8,375	7,754	475	429	3.35	4.02	5.50	5.30	6.1	6.2	M32	T4	135 °C
363.86	253.55	MVE 10370/6E-80A0	10,320	10,355	485	444	4.29	5.23	6.50	6.95	5.7	5.9	M32	T4	135 °C
403.58	284.10	MVE 11500/6E-85A0	11,446	11,603	582	547	5.10	5.36	6.92	6.36	5.7	5.7	M32	T4	135 °C
505.72	357.62	MVE 14360/6E-85A0	14,343	14,605	636	584	5.77	6.71	7.76	7.81	6.4	6.2	M32	T4	135 °C
A max. (Δ)															
623.26	403.56	MVE 17750/6E-85A0	17,676	16,482	682	604	7.38	8.85	12.60	11.60	6.2	6.4	M32	T4	135 °C
694.61	505.74	MVE 19120/6E-85A0	19,700	20,655	709	642	8.31	9.99	13.20	12.60	6.5	6.4	M32	T4	135 °C
622.40	403.56	MVE 17750/6E-86A0	17,652	16,482	682	604	6.17	7.38	9.00	10.00	6.0	6.2	M32	T4	135 °C
693.58	505.74	MVE 19120/6E-86A0	19,672	20,655	709	642	6.17	7.38	9.00	10.00	6.0	6.2	M32	T4	135 °C
776.23	538.19	MVE 21400/6E-90A0	22,015	21,980	825	766	8.18	8.58	14.00	12.70	6.6	6.6	M32	T4	135 °C
1,011.22	715.03	MVE 28660/6E-90A0	28,680	29,202	905	802	10.06	11.13	16.40	16.00	6.4	6.5	M32	T4	135 °C
782.53	538.19	MVE 21400/6E-91A0	22,194	21,980	823	766	8.58	10.33	13.00	14.50	6.0	6.0	M32	T4	135 °C
892.75	621.96	MVE 25100/6E-91A0	25,320	25,401	891	797	8.58	10.33	13.00	14.50	6.0	6.0	M32	T4	135 °C
1,003.04	715.03	MVE 28660/6E-91A0	28,448	29,202	905	802	10.73	11.94	17.20	18.10	5.6	6.3	M32	T4	135 °C
977.80	672.9	MVE 27400/6E-100A0	27,734	27,482	1,151	1049	10.72	12.74	15.0	15.0	5.0	5.5	M32	T4	135 °C
1,143.05	805.55	MVE 32800/6E-105A0	32,421	32,899	1,482	1389	13.53	16.09	18.0	18.0	5.8	5.8	M32	T4	135 °C
1,397.55	931.95	MVE 38000/6E-105A0	39,639	38,060	1,640	1508	15.98	19.04	21.0	21.0	5.6	5.9	M32	T4	135 °C
1,576.40	1,095.90	MVE 44750/6E-105A0	44,720	44,751	1,693	1605	16.04	19.44	24.0	24.0	5.4	5.6	M32	T4	135 °C
1,765.20	1,138	MVE 46400/6E-110A0	50,069	46,471	2,019	1914	18.71	22.80	28.0	28.0	4.8	5.3	M32	T4	135 °C
1,984.40	1,372.85	MVE 56000/6E-110A0	56,288	56,067	2,191	2066	18.71	22.80	28.0	28.0	4.8	5.3	M32	T4	135 °C



UP TO SIZE 60 (NOT INCLUDED)
60Hz masses = 50Hz masses adjusted at 70%



ABOVE SIZE 60 (INCLUDED)
Specific masses for 60Hz



- » II2D Ex tb IIIC Tx Db IP66
- » Equipment and protective system intended for use in potentially explosive atmospheres (Zone 21) - Directive 2014/34/UE
- » Compliance with Essential Health and Safety Requirements
- » IEC 60034-1, IEC EN 60079-0, IEC EN 60079-31



		DIMENSIONAL SPECIFICATIONS (inches)															
Model	Drawing	Size	C		M		A	B	Ø G	Holes	D	E	F	H	I	L	N
			50Hz	60Hz	50Hz	60Hz				n°							
MVE 90/6E-30A0	C	30A0	10.79		2.05		Multiple Footprint			4	5.91	6.81	0.59	3.11	5.91	6.54	5.28
							3.15	4.33	0.43								
							3.54	4.92	0.51								
							4.88	4.33	0.43								
MVE 220/6E-30A0	C	30A0	11.97		2.64		Multiple Footprint			4	5.91	6.81	0.59	3.11	5.91	6.54	5.28
							3.15	4.33	0.43								
							3.54	4.92	0.51								
							4.88	4.33	0.43								
MVE 410/6E-40A0	D1	40A0	12.99		3.07		4.13	5.51	0.51	4	6.69	7.72	0.79	3.62	6.85	6.54	6.30
MVE 680/6E-50A0	D1	50A0	15.39		3.82		4.72	6.69	0.67	4	8.19	8.27	0.87	3.78	7.28	7.56	6.69
MVE 1100/6E-50A0	D1	50A0	17.91		5.08		4.72	6.69	0.67	4	8.19	8.27	0.87	3.78	7.28	7.56	6.69
MVE 1600/6E-50A0	D1	50A0	17.91		5.08		4.72	6.69	0.67	4	8.19	8.27	0.87	3.78	7.28	7.56	6.69
MVE 1730/6E-60A0	D1	60A0	17.56		4.41		5.51	7.48	0.67	4	9.06	10.24	1.02	4.88	9.45	8.58	8.74
MVE 2350/6E-60A0	D1	60A0	19.29	17.56	5.28	4.41	5.51	7.48	0.67	4	9.06	10.24	1.02	4.88	9.45	8.58	8.74
MVE 3090/6E-60A0	D1	60A0	22.28	19.29	6.77	5.28	5.51	7.48	0.67	4	9.06	10.24	1.02	4.88	9.45	8.58	8.74
MVE 3580/6E-70A0	D1	70A0	22.17	19.72	6.06	4.84	6.10	8.86	0.87	4	10.83	11.42	1.18	5.51	10.08	9.84	9.29
MVE 4740/6E-70A0	D1	70A0	24.53	22.17	7.24	6.06	6.10	8.86	0.87	4	10.83	11.42	1.18	5.51	10.08	9.84	9.29
MVE 4850/6E-70A0	D1	70A0	24.53		7.24		6.10	8.86	0.87	4	10.83	11.42	1.18	5.51	10.08	9.84	9.29
MVE 5690/6E-75A0	D1	75A0	27.24	22.99	8.07	5.94	6.10	10.04	0.93	4	11.97	12.36	1.18	5.79	11.22	10.91	10.43
MVE 6620/6E-75A0	D1	75A0	27.24		8.07		6.10	10.04	0.93	4	11.97	12.36	1.18	5.79	11.22	10.91	10.43
MVE 8160/6E-75A0	D1	75A0	28.90	27.24	8.90	8.07	6.10	10.04	0.93	4	11.97	12.36	1.18	5.79	11.22	10.91	10.43
MVE 8450/6E-80A0	D1	80A0	26.89	23.74	7.20	5.63	7.09	11.02	1.02	4	13.07	13.94	1.26	6.69	12.99	12.28	12.24
MVE 10370/6E-80A0	D1	80A0	28.86	26.89	8.19	7.20	7.09	11.02	1.02	4	13.07	13.94	1.26	6.69	12.99	12.28	12.24
MVE 11500/6E-85A0	D1	85A0	27.72	24.57	6.69	5.12	7.87	12.60	1.10	4	15.16	15.83	1.57	7.99	15.51	14.17	14.88
MVE 14360/6E-85A0	D1	85A0	27.72		6.69		7.87	12.60	1.10	4	15.16	15.83	1.57	7.99	15.51	14.17	14.88
MVE 17750/6E-85A0	D1	85A0	30.47	27.72	8.07	6.69	7.87	12.60	1.10	4	15.16	15.83	1.57	7.99	15.51	14.17	14.88
MVE 19120/6E-85A0	D1	85A0	30.47	27.72	8.07	6.69	7.87	12.60	1.10	4	15.16	15.83	1.57	7.99	15.51	14.17	14.88
MVE 17750/6E-86A0	D1	86A0	30.47		8.07		7.87	12.60	1.10	4	15.16	15.83	1.57	7.99	15.51	14.17	14.88
MVE 19120/6E-86A0	D1	86A0	30.47		8.07		7.87	12.60	1.10	4	15.16	15.83	1.57	7.99	15.51	14.17	14.88
MVE 21400/6E-90A0	E1	90A0	35.75	31.42	10.24	8.07	4.92	14.96	1.54	6	17.80	16.34	1.57	8.07	15.51	14.96	14.88
MVE 28660/6E-90A0	E1	90A0	37.32	31.42	11.02	8.07	4.92	14.96	1.54	6	17.80	16.34	1.57	8.07	15.51	14.96	14.88
MVE 21400/6E-91A0	E1	91A0	35.75		10.24		4.92	14.96	1.54	6	17.80	16.34	1.57	8.07	15.51	14.96	14.88
MVE 25100/6E-91A0	E1	91A0	35.75		10.24		4.92	14.96	1.54	6	17.80	16.34	1.57	8.07	15.51	14.96	14.88
MVE 28660/6E-91A0	E1	91A0	37.32		11.02		4.92	14.96	1.54	6	17.80	16.34	1.57	8.07	15.51	14.96	14.88
MVE 27400/6E-100A0	E	100	40.16		10.83		5.51	17.32	1.77	6	20.87	19.06	1.46	9.13	17.56	18.50	16.69
MVE 32800/6E-105A0	H	105	38.58		8.27		5.51	18.90	1.77	8	22.44	21.34	1.89	10.55	20.08	22.05	19.29
MVE 38000/6E-105A0	H	105	41.73		9.84		5.51	18.90	1.77	8	22.44	21.34	1.89	10.55	20.08	22.05	19.29
MVE 44750/6E-105A0	H	105	41.73		9.84		5.51	18.90	1.77	8	22.44	21.34	1.89	10.55	20.08	22.05	19.29
MVE 46400/6E-110A0	H	110	44.49		11.22		5.51	19.47	1.77	8	24.02	23.39	1.65	11.69	22.05	22.05	20.87
MVE 56000/6E-110A0	H	110	44.49		11.22		5.51	19.47	1.77	8	24.02	23.39	1.65	11.69	22.05	22.05	20.87

STANDARD

EXPLOSION-PROOF

MILLING

SCREEN VIBRATOR

STAINLESS STEEL

NOTE: Dimensions with coarse degree of accuracy related to UNI 22768/1

This information is provided without warranty, representation, inducement or licence of any kind. It is accurate to the best OLI knowledge or is obtained from sources believed to be accurate. OLI therefore assumes no legal responsibility. The latest and most updated information are available online.



» Class II Div.2 Group F, G T4
 » Conform to UL 1004-1, UL 1004-3, UL60079-31, UL60079-0, CSA 60079-0, CSA 60079- 31, CSA 22.2 N°100, CSA 22.2 N°77



MVE STANDARD RANGE

8 POLES – 750/900 rpm



Unbalance (inlb)		Model	Centrifugal Force (lb)		Weight (lb)		ELECTRICAL SPECIFICATIONS						CERTIFICATE		
			50Hz	60Hz	50Hz	60Hz	Input Power (Hp)		Nominal Current A max. (Y)		Ia/In		Cable Gland	Class II Div.2	II 2D
50Hz	60Hz	60Hz	50Hz	60Hz	50Hz	60Hz	50Hz	60Hz	50Hz (400V)	60Hz (460V)	50Hz	60Hz	Metric	Temp. Class	Temp. Class
14.49		MVE 330/8E-40A	231	333		45	0.31	0.34	1.14	1.14	1.7	1.7	M20	T4	135 °C
24.71		MVE 550/8E-50A	395	567		63	0.34	0.40	0.90	0.89	1.9	1.9	M20	T4	135 °C
36.47		MVE 880/8E-50A0	582	838		75	0.34	0.40	0.90	0.89	2.1	2.1	M20	T4	135 °C
59.59		MVE 1430/8E-60A0	950	1,369		140	0.50	0.60	1.20	1.20	2.4	2.4	M25	T4	135 °C
81.47		MVE 2000/8E-60A0	1,299	1,872		153	0.74	0.72	1.23	1.29	2.7	2.7	M25	T4	135 °C
130.03		MVE 2900/8E-70A0	2,075	2,987		199	1.01	1.21	2.20	2.20	3.2	3.2	M25	T4	135 °C
202.87		MVE 4620/8E-75A0	3,236	4,661		332	1.34	1.61	2.81	2.89	4.4	4.3	M32	T4	135 °C
295.29		MVE 6820/8E-80A0	4,711	6,784		443	2.68	3.08	4.50	4.40	4.2	4.2	M32	T4	135 °C
363.90		MVE 8360/8E-80A0	5,805	8,360		483	3.35	4.02	6.00	6.00	4.1	4.2	M32	T4	135 °C
403.53		MVE 9240/8E-85A0	6,437	9,270		591	3.89	4.56	6.50	6.50	4.0	3.9	M32	T4	135 °C
505.74		MVE 11660/8E-85A0	8,069	11,618		637	4.96	5.77	8.00	8.20	4.0	4.4	M32	T4	135 °C
623.20		MVE 14300/8E-85A0	9,943	14,317		679	5.10	5.63	8.78	8.30	3.8	4.2	M32	T4	135 °C
									A max. (Δ)						
955.05		MVE 22000/8E-90A0	15,236	21,940		931	9.12	10.06	13.50	12.50	3.7	4.4	M32	T4	135 °C
1,003.04		MVE 22000/8E-91A0	16,001	23,042		931	8.05	9.39	14.40	14.00	4.7	4.7	M32	T4	135 °C
1,230.05	1,107.98	MVE 25400/8E-100A0	19,630	25,454	1,259	1,219	10.06	10.73	13.5	13.5	3.8	4.0	M32	T4	135 °C
1,611.50	1,397.55	MVE 32100/8E-105A0	25,708	32,106	1,656	1,598	12.07	14.21	19.0	19.0	4.5	5.0	M32	T4	135 °C
1,910.07	1,701.55	MVE 39000/8E-105A0	30,472	39,085	1,790	1,746	12.20	14.75	20.0	20.0	5.3	5.8	M32	T4	135 °C
2,542.10	2,169.55	MVE 49800/8E-110A0	40,554	49,846	2,165	2,066	18.51	22.13	28.0	28.0	5.6	5.2	M32	T4	135 °C
-	2,542.10	MVE 58300/8E-110A0	-	58,398	-	2,165	-	22.13	-	28.0	-	5.2	M32	T4	135 °C

SIZE 40A0



SIZE 50A0



SIZE 60A0



UP TO SIZE 90 (INCLUDED)
60Hz masses = 50Hz masses adjusted at 100%



ABOVE SIZE 90 (NOT INCLUDED)
Specific masses for 60Hz



- » IIE2 Ex tb IIIC Tx Db IP66
- » Equipment and protective system intended for use in potentially explosive atmospheres (Zone 21) - Directive 2014/34/UE
- » Compliance with Essential Health and Safety Requirements
- » IEC 60034-1, IEC EN 60079-0, IEC EN 60079-31



DIMENSIONAL SPECIFICATIONS (inches)

Model	Drawing	Size	C	M	A	B	ØG	Holes	D	E	F	H	I	L	N
			50Hz-60Hz	50Hz-60Hz				n°							
MVE 330/8E-40A	D1	40A0	12.99	3.07	4.13	5.51	0.51	4	6.69	7.72	0.79	3.62	6.85	6.54	6.30
MVE 550/8E-50A	D1	50A0	15.39	3.82	4.72	6.69	0.67	4	8.19	8.27	0.87	3.78	7.28	7.56	6.69
MVE 880/8E-50A0	D1	50A0	17.91	5.08	4.72	6.69	0.67	4	8.19	8.27	0.87	3.78	7.28	7.56	6.69
MVE 1430/8E-60A0	D1	60A0	17.56	4.41	5.51	7.48	0.67	4	9.06	10.24	1.02	4.88	9.45	8.58	8.74
MVE 2000/8E-60A0	D1	60A0	19.29	5.28	5.51	7.48	0.67	4	9.06	10.24	1.02	4.88	9.45	8.58	8.74
MVE 2900/8E-70A0	D1	70A0	22.17	6.06	6.10	8.86	0.87	4	10.83	11.42	1.18	5.51	10.08	9.84	9.29
MVE 4620/8E-75A0	D1	75A0	27.24	8.07	6.10	10.04	0.93	4	11.97	12.36	1.18	5.79	11.22	10.91	10.43
MVE 6820/8E-80A0	D1	80A0	26.89	7.20	7.09	11.02	1.02	4	13.07	13.94	1.26	6.69	12.99	12.28	12.24
MVE 8360/8E-80A0	D1	80A0	28.86	8.19	7.09	11.02	1.02	4	13.07	13.94	1.26	6.69	12.99	12.28	12.24
MVE 9240/8E-85A0	D1	85A0	27.72	6.69	7.87	12.60	1.10	4	15.16	15.83	1.57	7.99	15.51	14.17	14.88
MVE 11660/8E-85A0	D1	85A0	27.72	6.69	7.87	12.60	1.10	4	15.16	15.83	1.57	7.99	15.51	14.17	14.88
MVE 14300/8E-85A0	D1	85A0	30.47	8.07	7.87	12.60	1.10	4	15.16	15.83	1.57	7.99	15.51	14.17	14.88
MVE 22000/8E-90A0	E1	90A0	37.32	11.02	4.92	14.96	1.54	6	17.80	16.34	1.57	8.07	15.51	14.96	14.88
MVE 22000/8E-91A0	E1	91A0	37.32	11.02	4.92	14.96	1.54	6	17.80	16.34	1.57	8.07	15.51	14.96	14.88
MVE 25400/8E-100A0	E	100	40.16	10.83	5.51	17.32	1.77	6	20.87	19.06	1.46	9.13	17.56	18.50	16.69
MVE 32100/8E-105A0	H	105	41.73	9.84	5.51	18.90	1.77	8	22.44	21.34	1.89	10.55	20.08	22.05	19.29
MVE 39000/8E-105A0	H	105	44.09	11.02	5.51	18.90	1.77	8	22.44	21.34	1.89	10.55	20.08	22.05	19.29
MVE 49800/8E-110A0	H	110	44.49	11.22	5.51	20.47	1.77	8	24.02	23.39	1.65	11.69	22.05	22.05	20.87
MVE 58300/8E-110A0	H	110	44.49	11.22	5.51	20.47	1.77	8	24.02	23.39	1.65	11.69	22.05	22.05	20.87

Notes:

NOTE: Dimensions with coarse degree of accuracy related to UNI 22768/1

This information is provided without warranty, representation, inducement or licence of any kind. It is accurate to the best OLI knowledge or is obtained from sources believed to be accurate. OLI therefore assumes no legal responsibility. The latest and most updated information are available online.



» Class II Div.2 Group F, G T4
 » Conform to UL 1004-1, UL 1004-3, UL60079-31, UL60079-0, CSA 60079-0, CSA 60079- 31, CSA 22.2 N°100, CSA 22.2 N°77

STANDARD

EXPLOSION-PROOF

MILLING

SCREEN VIBRATOR

STAINLESS STEEL



MVE STANDARD RANGE

2 POLES SINGLE-PHASE – 3000/3600 rpm



Unbalance (inlb)		Model	Centrifugal Force (lb)		Weight (lb)		ELECTRICAL SPECIFICATIONS						CERTIFICATE		
			50Hz	60Hz	50Hz	60Hz	Input Power (Hp)		Nominal Current A max		Cable Gland	Capacitor *		Class II Div.2	II 2D
50Hz	60Hz	60Hz	50Hz	60Hz	50Hz	60Hz	50Hz	60Hz	50Hz (230V)	60Hz (115V)	Metric	50Hz (230V)	60Hz (115V)	Temp. Class	Temp. Class
0.57	0.43	MVE 160/2E-10A0-M	146	157	9		0.11	0.12	0.43	1.03	M16	3.0	6.3	T4	100 °C
0.85	0.57	MVE 220/2E-10A0-M	216	209	11		0.13	0.15	0.54	1.30	M16	4.0	8.0	T4	100 °C
1.61	1.13	MVE 440/2E-20A0-M	412	417	15		0.24	0.28	1.14	2.62	M20	8.0	16.0	T4	100 °C
1.61	1.13	MVE 440/2E-23A0-M	412	417	16		0.24	0.28	1.14	2.62	M20	8.0	16.0	T4	100 °C
2.77	1.94	MVE 690/2E-30A0-M	708	712	22		0.36	0.38	1.58	3.43	M20	12.5	25.0	T4	100 °C

* NOTE: Capacitor not supplied with vibrator (to be ordered separately)

SIZE 10A0



SIZE20A0



SIZE 30A0





Model	Drawing	Size	DIMENSIONAL SPECIFICATIONS (inches)														
			C		M		A	B	Ø G	Holes	D	E	F	H	I	L	N
			50Hz	60Hz	50Hz	60Hz				n°							
MVE 160/2E-10A0-M	A1	10A0	8.39	1.77	Multiple Footprint 2.44-2.91 4.17 0.35 1.30 3.27-4.02 0.28			4	5.12	5.31	0.41	1.97	3.78	4.21	3.35		
MVE 220/2E-10A0-M	A1	10A0	8.39	1.77	Multiple Footprint 2.44-2.91 4.17 0.35 1.30 3.27-4.02 0.28			4	5.12	5.31	0.41	1.97	3.78	4.21	3.35		
MVE 440/2E-20A0-M	B1	20A0	9.17	2.13	2.44-2.91	4.17	0.35	4	5.12	6.06	0.59	2.56	4.92	4.72	4.41		
MVE 440/2E-23A0-M	G	23A0	8.74	2.17	Multiple Footprint 2.44-2.91 4.17 0.35 2.56 5.51 0.51 4.53 5.31 0.43 5.31 4.53 0.43			4	6.46	5.51	0.98	3.23	4.57	6.26	4.33		
MVE 690/2E-30A0-M	C1	30A0	10.00	1.65	Multiple Footprint 3.15 4.33 0.43 3.54 4.92 0.51 4.88 4.33 0.43 5.31 4.53 0.43			4	6.06	6.81	0.59	3.11	5.91	6.54	5.28		

STANDARD

EXPLOSION-PROOF

MILLING

SCREEN VIBRATOR

STAINLESS STEEL

Notes:

.....

.....

.....

.....

NOTE: Dimensions with coarse degree of accuracy related to UNI 22768/1

This information is provided without warranty, representation, inducement or licence of any kind. It is accurate to the best OLI knowledge or is obtained from sources believed to be accurate. OLI therefore assumes no legal responsibility. The latest and most updated information are available online.



» Class II Div.2 Group F, G T4
 » Conform to UL 1004-1, UL 1004-3, UL60079-31, UL60079-0, CSA 60079-0, CSA 60079- 31, CSA 22.2 N°100, CSA 22.2 N°77



MVE STANDARD RANGE

MVE-MICRO - 3000/3600 rpm



THREE-PHASE

Unbalance (inlb)		Model	Centrifugal Force (lb)		Weight (lb)		ELECTRICAL SPECIFICATIONS					CERTIFICATE		
			50Hz	60Hz	50Hz	60Hz	Input Power (Hp)		Nominal Current A max			Cable Gland	For 60Hz	For 50Hz
50Hz	60Hz	60Hz	50Hz	60Hz	50Hz	60Hz	50Hz	60Hz	50Hz (230V)	50Hz (400V)	60Hz (460V)	Metric	Class II Div.2	II3D
0.17		MVE 21/36E-MICRO	44	64	4		0.05	0.05	0.21	0.12	0.12	M16	Class II Div.2	II3D
0.39		MVE41/36E-MICRO	99	143	5		0.08	0.08	0.30	0.18	0.18	M16	Temp. Class	Temp. Class
													T4	100 °C
													T4	100 °C

SINGLE-PHASE

Unbalance (inlb)		Model	Centrifugal Force (lb)		Weight (lb)		ELECTRICAL SPECIFICATIONS					CERTIFICATE	
			50Hz	60Hz	50Hz	60Hz	Input Power (Hp)		Nominal Current A max		Cable Gland *	For 60Hz	For 50Hz
50Hz	60Hz	60Hz	50Hz	60Hz	50Hz	60Hz	50Hz	60Hz	50Hz (230V)	60Hz (115V)	Metric	Class II Div.2	II3D
0.03		MVE 3/36E-MICRO-M	9	13	3		0.04	0.05	0.30	0.80	M16	Class II Div.2	II3D
0.05		MVE 6/36E-MICRO-M	13	20	3		0.04	0.05	0.30	0.80	M16	Temp. Class	Temp. Class
0.17		MVE 21/36E-MICRO-M	44	64	4		0.05	0.09	0.20	0.80	M16	T4	100 °C
0.39		MVE 41/36E-MICRO-M	99	143	5		0.07	0.09	0.25	0.80	M16	T4	100 °C

MICRO



NOTE: Capacitor integrated in the cable



F

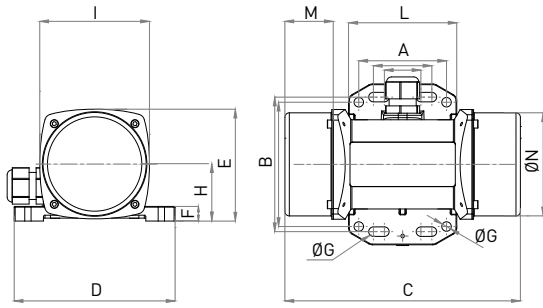

I

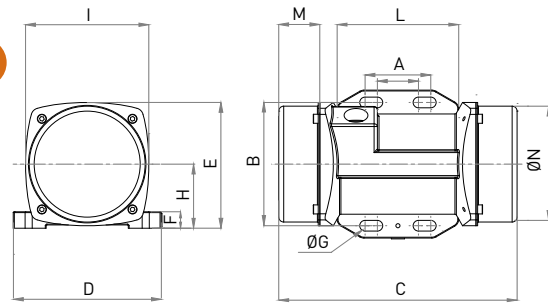

DIMENSIONAL SPECIFICATIONS (inches)

Model	Drawing	C	M	Multiple Footprint			Holes	D	E	F	H	I	L	N
		60Hz	60Hz	0.98-1.57	3.62	0.26								
MVE 21/36E-MICRO	F	5.71	0.98	0.98-1.57	3.62	0.26	4	4.33	3.01	0.39	1.54	2.95	2.91	2.78
MVE41/36E-MICRO	F	6.34	1.30	0.98-1.60	3.62	0.26	4	4.33	3.01	0.39	1.54	2.95	2.91	2.78

DIMENSIONAL SPECIFICATIONS (inches)

Model	Drawing	C	M	Multiple Footprint			Holes	D	E	F	H	I	L	N
		60Hz	60Hz	0.98-1.57	3.62	0.26								
MVE 3/36E-MICRO-M	F	5.71	0.98	0.98-1.57	3.62	0.26	4	4.33	3.01	0.39	1.54	2.95	2.91	2.78
MVE 6/36E-MICRO-M	F	5.71	0.98	0.98-1.57	2.95	0.26	4	3.54	3.01	0.39	1.54	2.95	2.91	2.78
MVE 21/36E-MICRO-M	F	5.71	0.98	0.98-1.57	3.62	0.26	4	4.33	3.01	0.39	1.54	2.95	2.91	2.78
MVE 41/36E-MICRO-M	F	6.34	1.30	0.98-1.57	3.62	0.26	4	4.33	3.01	0.39	1.54	2.95	2.91	2.78

Notes:

.....

.....

.....

.....

NOTE: Dimensions with coarse degree of accuracy related to UNI 22768/1

This information is provided without warranty, representation, inducement or licence of any kind. It is accurate to the best OLI knowledge or is obtained from sources believed to be accurate. OLI therefore assumes no legal responsibility. The latest and most updated information are available online.



» Class II Div.2 Group F, G T4
 » Conform to UL 1004-1, UL 1004-3, UL60079-31, UL60079-0, CSA 60079-0, CSA 60079- 31, CSA 22.2 N°100, CSA 22.2 N°77

STANDARD
 EXPLOSION-PROOF
 MILLING
 SCREEN VIBRATOR
 STAINLESS STEEL



MVE STANDARD RANGE



MVE-DC DIRECT CURRENT - 3000 rpm

Unbalance (inlb)	Model	rpm	Centrifugal Force (lb)	Weight (lb)	ELECTRICAL SPECIFICATIONS			CERTIFICATE
					Input Power (Hp)	Nominal Current A max	Cable Gland	I13D
0.44	MVE 50/3N-10A0-12V	3,000	110	10	0.11	6.60	M16	100 °C
0.44	MVE 50/3N-10A0-24V	3,000	110	10	0.11	3.30	M16	100 °C
0.93	MVE 120/3N-23A0-12V	3,000	258	16	0.15	9.60	M20	100 °C
0.93	MVE 120/3N-23A0-24V	3,000	258	16	0.15	4.80	M20	100 °C
1.81	MVE 202/3N-23A0-12V	3,000	441	16	0.21	13.30	M20	100 °C
1.81	MVE 202/3N-23A0-24V	3,000	441	16	0.21	6.70	M20	100 °C
4.51	MVE 500/3N-40A0-24V	3,000	1,168	35	0.35	11.00	M20	100 °C
9.72	MVE 1500/3N-50A0-24V	3,000	3,563	51	0.70	21.50	M20	100 °C

SIZE 23A0



SIZE 40A0



SIZE 50A0



- » I13D Ex tc IIIC Tx IP66
- » Equipment and protective system intended for use in potentially explosive atmospheres [Zone 22] - Directive 2014/34/UE
- » Compliance with Essential Health and Safety Requirements
- » IEC EN 60079-0, IEC EN 60079-31



Model	Drawing	Size	DIMENSIONAL SPECIFICATIONS (inches)												
			C	M	A	B	Ø G	Holes	D	E	F	H	I	L	N
								N°							
MVE 50/3N-10A0-12V	A	10A0	8.31	1.77	Multiple Footprint			4	5.12	5.35	0.47	1.89	3.70	4.76	3.35
MVE 50/3N-10A0-24V	A	10A0	8.31	1.77	2.44-2.91	4.17	0.35								
MVE 120/3N-23A0-12V	G	23A0	8.58	2.09	Multiple Footprint			4	6.46	5.51	0.98	3.23	4.57	6.26	4.33
MVE 120/3N-23A0-24V	G	23A0	8.58	2.09	2.44-2.91	4.17	0.35								
MVE 202/3N-23A0-12V	G	23A0	8.58	2.09	Multiple Footprint			4	6.46	5.51	0.98	3.23	4.57	6.26	4.33
MVE 202/3N-23A0-24V	G	23A0	8.58	2.09	4.53	5.31	0.43								
MVE 500/3N-40A0-24V	D1	40A0	12.99	3.07	4.13	5.51	0.51	4	6.69	7.70	0.59	3.62	6.85	6.50	6.30
MVE 1500/3N-50A0-24V	D1	50A0	12.75	2.48	4.72	6.69	0.71	4	8.19	8.26	0.71	3.78	7.28	7.55	6.49

STANDARD

EXPLOSION-PROOF

MILLING

SCREEN VIBRATOR

STAINLESS STEEL

Notes:

.....

.....

.....

.....

NOTE: Dimensions with coarse degree of accuracy related to UNI 22768/1

This information is provided without warranty, representation, inducement or licence of any kind. It is accurate to the best OLI knowledge or is obtained from sources believed to be accurate. OLI therefore assumes no legal responsibility. The latest and most updated information are available online.



MVE-Exd EXPLOSION-PROOF



2 POLES - 3000/3600 rpm

Unbalance (inlb)		Model	Centrifugal Force (lb)		Weight (lb)	
50Hz	60Hz		50Hz	60Hz	50Hz	60Hz
6.81	4.80	MVE 1800/2D-50A0	1,750	1,764	88	
11.54	8.07	MVE 3100/2D-50A0	2,987	3,009	91	
13.57	9.64	MVE 3500/2D-60A0	3,530	3,545	138	137
15.96	11.98	MVE 4100/2D-60A0	4,469	4,403	141	139
19.95	13.83	MVE 5100/2D-60A0	5,075	5,084	144	140
29.56	19.05	MVE 7600/2D-75A0	7,169	7,002	231	227
34.46	24.30	MVE 8800/2D-75A0	8,891	8,933	238	229

ELECTRICAL SPECIFICATIONS									
Input Power (Hp)		Nominal Current A max. (Y)		Ia / In		Cable Gland			
50Hz	60Hz	50Hz (400V)	60Hz (460V)	50Hz	60Hz	Metric			
1.01	1.21	1.45	1.50	3.8	3.8	3/4" NPT 110 °C			
1.48	1.48	2.00	2.75	5.2	5.0	3/4" NPT 110 °C			
2.11	2.15	2.94	2.61	5.9	6.2	3/4" NPT 110 °C			
1.68	1.88	3.20	2.80	6.5	6.4	3/4" NPT 110 °C			
1.68	1.88	3.20	2.80	6.0	6.3	3/4" NPT 110 °C			
4.02	4.02	5.20	4.60	8.3	8.2	3/4" NPT 110 °C			
4.02	4.02	5.20	4.60	8.5	9.7	3/4" NPT 110 °C			

4 POLES - 1500/1800 rpm

Unbalance (inlb)		Model	Centrifugal Force (lb)		Weight (lb)	
50Hz	60Hz		50Hz	60Hz	50Hz	60Hz
24.67	17.08	MVE 1530/4D-50A0	1,574	1,570	99	
38.49	24.67	MVE 2300/4D-50A0	2,456	2,266	115	99
47.12	33.30	MVE 3100/4D-60A0	3,007	3,060	161	155
59.59	39.92	MVE 3880/4D-60A0	3,803	3,668	168	134
81.46	59.62	MVE 5340/4D-60A0	5,198	5,478	172	159
88.34	58.87	MVE 5700/4D-70A0	5,637	5,410	218	204
107.93	73.68	MVE 6840/4D-70A0	6,887	6,770	231	214
133.11	88.86	MVE 8400/4D-75A0	8,494	8,166	300	276
83.77	83.77	MVE 8411/4D-75A0	5,346	7,698	300	276
148.97	104.58	MVE 9480/4D-75A0	9,506	9,610	310	286
189.84	131.83	MVE 12260/4D-80A0	12,114	12,114	427	403

ELECTRICAL SPECIFICATIONS									
Input Power (Hp)		Nominal Current A max. (Y)		Ia/In		Cable Gland			
50Hz	60Hz	50Hz (400V)	60Hz (460V)	50Hz	60Hz	Metric			
0.74	0.89	1.00	1.00	3.0	3.2	3/4" NPT 110 °C			
0.80	0.91	1.27	1.50	3.8	3.8	3/4" NPT 110 °C			
1.01	1.34	1.67	1.80	4.0	4.0	3/4" NPT 110 °C			
1.34	1.61	1.95	2.00	4.7	4.5	3/4" NPT 110 °C			
1.68	1.88	2.80	2.70	4.9	4.9	3/4" NPT 110 °C			
2.01	2.15	2.70	2.60	6.0	6.1	3/4" NPT 110 °C			
2.21	2.55	2.80	2.70	6.5	6.6	3/4" NPT 110 °C			
3.08	3.02	4.10	3.96	6.8	6.8	3/4" NPT 110 °C			
3.08	3.02	4.10	3.96	6.8	6.8	3/4" NPT 110 °C			
3.22	3.49	4.30	4.10	7.0	7.2	3/4" NPT 110 °C			
4.16	4.16	5.70	5.30	7.1	7.0	3/4" NPT 110 °C			

SIZE 50A0



UP TO SIZE 50 (INCLUDED)
60Hz masses = 50Hz masses adjusted at 70%
Except for model MVE 1100/15D - 1100/18D



ABOVE SIZE 50 (NOT INCLUDED)
Specific masses for 60Hz



- » II 2 GD
- » Ex db IIB T4
- » Ex tb IIIC IP66 Tx
- » Compliance with Essential Health and Safety Requirements
- » IEC EN 60079-0, IEC EN 60079-31, IEC EN 60079-1

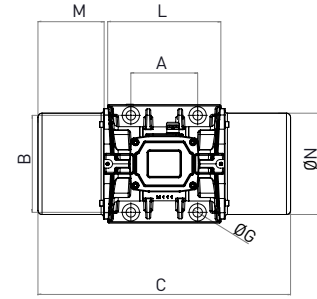
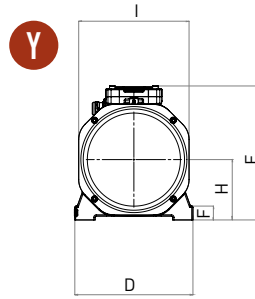
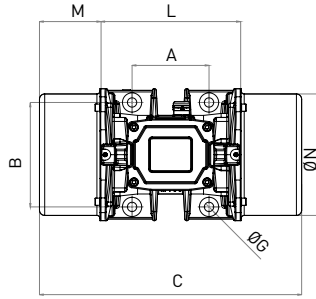
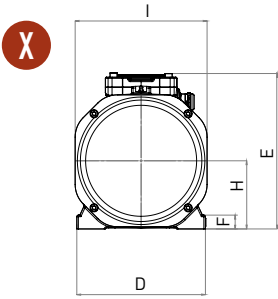

DIMENSIONAL SPECIFICATIONS (inches)

Model	Drawing	Size	C		M		A	B	Ø G	Holes	D	E	F	H	I	L	N
			50Hz	60Hz	50Hz	60Hz				n°							
MVE 1800/2D-50A0	X	50A0	13.07		2.50		4.72	6.69	0.67	4	8.23	9.88	1.06	4.06	7.28	8.07	6.52
MVE 3100/2D-50A0	X	50A0	13.07		2.50		4.72	6.69	0.67	4	8.23	9.88	1.06	4.06	7.28	8.07	6.52
MVE 3500/2D-60A0	X	60A0	18.78		4.39		5.51	7.48	0.67	4	9.21	11.14	0.98	4.88	9.45	10.00	8.70
MVE 4100/2D-60A0	X	60A0	18.78		4.39		5.51	7.48	0.67	4	9.21	11.14	0.98	4.88	9.45	10.00	8.70
MVE 5100/2D-60A0	X	60A0	18.78		4.39		5.51	7.48	0.67	4	9.21	11.14	0.98	4.88	9.45	10.00	8.70
MVE 7600/2D-75A0	Y	75A0	21.26		4.65		6.10	10.04	0.93	4	11.89	12.99	1.18	5.91	11.02	11.97	10.43
MVE 8800/2D-75A0	Y	75A0	21.81		4.92		6.10	10.04	0.93	4	11.89	12.99	1.18	5.91	11.02	11.97	10.43

DIMENSIONAL SPECIFICATIONS (inches)

Model	Drawing	Size	C		M		A	B	Ø G	Holes	D	E	F	H	I	L	N
			50Hz	60Hz	50Hz	60Hz				n°							
MVE 1530/4D-50A0	X	50A0	15.59		3.76		4.72	6.69	0.67	4	8.23	9.88	1.06	4.06	7.28	8.07	6.52
MVE 2300/4D-50A0	X	50A0	18.35	15.59	5.14	3.76	4.72	6.69	0.67	4	8.23	9.88	1.06	4.06	7.28	8.07	6.52
MVE 3100/4D-60A0	X	60A0	18.78		4.39		5.51	7.48	0.67	4	9.21	11.14	0.98	4.88	9.45	10.00	8.70
MVE 3880/4D-60A0	X	60A0	18.78		4.39		5.51	7.48	0.67	4	9.21	11.14	0.98	4.88	9.45	10.00	8.70
MVE 5340/4D-60A0	X	60A0	20.51		5.26		5.51	7.48	0.67	4	9.21	11.14	0.98	4.88	9.45	10.00	8.70
MVE 5700/4D-70A0	Y	70A0	20.67		4.84		6.10	8.86	0.87	4	10.79	12.24	1.26	5.51	10.08	10.98	9.25
MVE 6840/4D-70A0	Y	70A0	23.07		6.04		6.10	8.86	0.87	4	10.79	12.24	1.26	5.51	10.08	10.98	9.25
MVE 8400/4D-75A0	Y	75A0	23.46		5.75		6.10	10.04	0.93	4	11.89	12.99	1.18	5.91	11.02	11.97	10.43
MVE 8411/4D-75A0	Y	75A0	23.46		5.75		6.10	10.04	0.93	4	11.89	12.99	1.18	5.91	11.02	11.97	10.43
MVE 9480/4D-75A0	Y	75A0	24.25		6.14		6.10	10.04	0.93	4	11.89	12.99	1.18	5.91	11.02	11.97	10.43
MVE 12260/4D-80A0	Y	80A0	24.09		5.00		7.09	11.02	1.02	4	12.99	14.92	1.30	6.93	12.99	14.09	12.20

Notes:

.....

.....

.....

.....

NOTE: Dimensions with coarse degree of accuracy related to UNI 22768/1

This information is provided without warranty, representation, inducement or licence of any kind. It is accurate to the best OLI knowledge or is obtained from sources believed to be accurate. OLI therefore assumes no legal responsibility. The latest and most updated information are available online.



» Class I, Div.1 Group C, D T4 IP66
 » Conform to UL 1004-1, UL 674, CSA 22.2 60079-0, CSA 22.2 60079-31, CSA 22.2 100, CSA 22.2 25, CSA 22.2 145, CSA 22.2 60079-1

STANDARD
 EXPLOSION-PROOF
 MILLING
 SCREEN VIBRATOR
 STAINLESS STEEL



MVE-Exd EXPLOSION-PROOF



6 POLES - 1000/1200 rpm

Unbalance (inlb)		Model	Centrifugal Force (lb)		Weight (lb)	
50Hz	60Hz		50Hz	60Hz	50Hz	60Hz
39.88		MVE 1100/6D-50A	1,131	1,629	119	
59.62	47.13	MVE 1730/6D-60A0	1,691	1,925	161	156
81.46	59.59	MVE 2350/6D-60A0	2,310	2,434	176	162
123.59	85.29	MVE 3090/6D-60A0	3,505	3,483	207	184
130.05	88.31	MVE 3580/6D-70A0	3,688	3,607	240	218
161.92	107.96	MVE 4740/6D-70A0	4,592	4,409	266	237
202.88	133.12	MVE 5690/6D-75A0	5,754	5,437	336	299
234.52	164.80	MVE 6620/6D-75A0	6,651	6,731	355	297
295.30	189.85	MVE 8450/6D-80A0	8,375	7,754	475	432
363.86	253.55	MVE 10370/6D-80A0	10,320	10,355	509	467

ELECTRICAL SPECIFICATIONS							
Input Power (Hp)		Nominal Current A max. (Y)		Ia/In		Cable Gland	
50Hz	60Hz	50Hz (400V)	60Hz (460V)	50Hz	60Hz	Metric	
0.40	0.43	1.10	1.05	2.8	2.7	3/4" NPT 110 °C	
0.76	0.91	1.14	1.21	3.2	3.1	3/4" NPT 110 °C	
0.75	0.78	1.40	1.30	3.2	3.1	3/4" NPT 110 °C	
1.07	1.21	1.60	1.70	3.3	3.3	3/4" NPT 110 °C	
1.34	1.52	2.50	2.72	3.7	3.6	3/4" NPT110 °C	
1.61	1.81	2.80	3.00	4.3	4.4	3/4" NPT 110 °C	
2.01	2.15	3.50	3.30	4.8	4.8	3/4" NPT 110 °C	
2.35	2.55	4.30	4.00	5.0	5.0	3/4" NPT 110 °C	
2.82	3.08	5.00	4.80	5.9	6.0	3/4" NPT110 °C	
3.35	3.75	6.20	6.00	5.5	5.7	3/4" NPT 110 °C	

8 POLES - 750/900 rpm

Unbalance (inlb)		Model	Centrifugal Force (lb)		Weight (lb)
50Hz	60Hz		50Hz	60Hz	50Hz-60Hz
24.71		MVE 550/8D-50A0	395	567	103
36.47		MVE 880/8D-50A0	582	838	119
59.59		MVE 1430/8D-60A0	950	1,369	161
81.47		MVE 2000/8D-60A0	1,299	1,872	181
130.03		MVE 2900/8D-70A0	2,075	2,987	240
202.87		MVE 4620/8D-75A0	3,236	4,661	337
295.29		MVE 6820/8D-80A0	4,711	6,784	472
363.90		MVE 8360/8D-80A0	5,805	8,360	507

ELECTRICAL SPECIFICATIONS							
Input Power (Hp)		Nominal Current A max. (Y)		Ia/In		Cable Gland	
50Hz	60Hz	50Hz (400V)	60Hz (460V)	50Hz	60Hz	Metric	
0.47	0.51	1.15	1.15	1.7	1.7	3/4" NPT 110 °C	
0.47	0.51	1.15	1.15	1.9	1.9	3/4" NPT 110 °C	
0.58	0.67	1.12	1.10	2.2	2.2	3/4" NPT 110 °C	
0.74	0.80	1.40	1.20	2.5	2.5	3/4" NPT 110 °C	
1.07	1.07	2.20	2.10	3.0	3.0	3/4" NPT 110 °C	
1.68	1.74	3.20	2.80	4.2	4.1	3/4" NPT 110 °C	
2.01	2.41	3.80	3.80	4.0	4.0	3/4" NPT110 °C	
3.35	4.29	5.50	5.70	3.9	4.0	3/4" NPT 110 °C	

SIZE 60A0



- » II 2 GD
- » Ex db IIB T4
- » Ex tb IIIC IP66 Tx
- » Compliance with Essential Health and Safety Requirements
- » IEC EN 60079-0, IEC EN 60079-31, IEC EN 60079-1

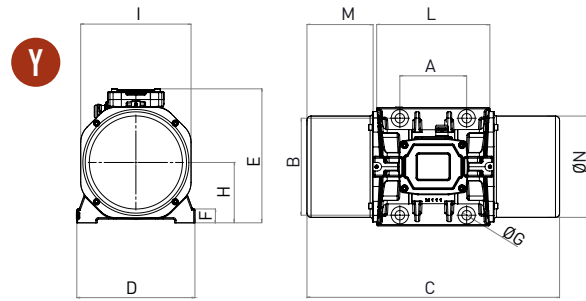
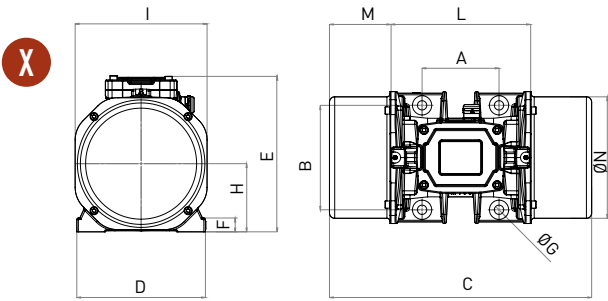

DIMENSIONAL SPECIFICATIONS (inches)

Model	Drawing	Size	C		M		A	B	Ø G	Holes	D	E	F	H	I	L	N
			50Hz	60Hz	50Hz	60Hz											
			n°														
MVE 1100/6D-50A	X	50A0	18.35	5.14	4.72	6.69	0.67	4	8.23	9.88	1.06	4.06	7.28	8.07	6.52		
MVE 1730/6D-60A0	X	60A0	18.78	4.39	5.51	7.48	0.67	4	9.21	11.14	0.98	4.88	9.45	10.00	8.70		
MVE 2350/6D-60A0	X	60A0	20.51	5.26	5.51	7.48	0.67	4	9.21	11.14	0.98	4.88	9.45	10.00	8.70		
MVE 3090/6D-60A0	X	60A0	23.50	6.75	5.51	7.48	0.67	4	9.21	11.14	0.98	4.88	9.45	10.00	8.70		
MVE 3580/6D-70A0	Y	70A0	23.07	6.04	6.10	8.86	0.87	4	10.79	12.24	1.26	5.51	10.08	10.98	9.25		
MVE 4740/6D-70A0	Y	70A0	25.43	7.22	6.10	8.86	0.87	4	10.79	12.24	1.26	5.51	10.08	10.98	9.25		
MVE 5690/6D-75A0	Y	75A0	28.50	8.27	6.10	10.04	0.93	4	11.89	12.99	1.18	5.91	11.02	11.97	10.39		
MVE 6620/6D-75A0	Y	75A0	28.50	8.27	6.10	10.04	0.93	4	11.89	12.99	1.18	5.91	11.02	11.97	10.39		
MVE 8450/6D-80A0	Y	80A0	27.24	6.57	7.09	11.02	1.02	4	12.99	14.92	1.30	6.93	12.99	14.09	12.20		
MVE 10370/6D-80A0	Y	80A0	29.29	7.60	7.09	11.02	1.02	4	12.99	14.92	1.30	6.93	12.99	14.09	12.20		

DIMENSIONAL SPECIFICATIONS (inches)

Model	Drawing	Size	C	M	A	B	Ø G	Holes	D	E	F	H	I	L	N
			50Hz-60Hz	50Hz-60Hz											
			n°												
MVE 550/8D-50A0	X	50A0	15.59	3.76	4.72	6.69	0.67	4	8.23	9.88	1.06	4.06	7.28	8.07	6.52
MVE 880/8D-50A0	X	50A0	18.35	5.14	4.72	6.69	0.67	4	8.23	9.88	1.06	4.06	7.28	8.07	6.52
MVE 1430/8D-60A0	X	60A0	18.78	4.39	5.51	7.48	0.67	4	9.21	11.14	0.98	4.88	9.45	10.00	8.70
MVE 2000/8D-60A0	X	60A0	20.51	5.26	5.51	7.48	0.67	4	9.21	11.14	0.98	4.88	9.45	10.00	8.70
MVE 2900/8D-70A0	Y	70A0	23.07	6.04	6.10	8.86	0.87	4	10.79	12.24	1.26	5.51	10.08	10.98	9.25
MVE 4620/8D-75A0	Y	75A0	28.50	8.27	6.10	10.04	0.93	4	11.89	12.99	1.18	5.91	11.02	11.97	10.39
MVE 6820/8D-80A0	Y	80A0	27.24	6.57	7.09	11.02	1.02	4	12.99	14.92	1.30	6.93	12.99	14.09	12.20
MVE 8360/8D-80A0	Y	80A0	29.29	7.60	7.09	11.02	1.02	4	12.99	14.92	1.30	6.93	12.99	14.09	12.20

Notes:

.....

.....

.....

.....

NOTE: Dimensions with coarse degree of accuracy related to UNI 22768/1

This information is provided without warranty, representation, inducement or licence of any kind. It is accurate to the best OLI knowledge or is obtained from sources believed to be accurate. OLI therefore assumes no legal responsibility. The latest and most updated information are available online.



» Class I, Div.1 Group C, D T4 IP66
 » Conform to UL 1004-1, UL 674, CSA 22.2 60079-0, CSA 22.2 60079-31, CSA 22.2 100, CSA 22.2 25, CSA 22.2 145, CSA 22.2 60079-1

STANDARD

EXPLOSION-PROOF

MILLING

SCREEN VIBRATOR

STAINLESS STEEL



MVE-MILLING GRAIN PURIFIER



8 POLES - 750 rpm

Unbalance (inlb)		Model		Centrifugal Force (lb)		Weight (lb)		ELECTRICAL SPECIFICATIONS						CERTIFICATE	
								Input Power (Hp)		Nominal Current A max. (Y)		Ia / In		Cable Gland	Ex II3D
50Hz	60Hz	50Hz	60Hz	50Hz	60Hz	50Hz	60Hz	50Hz (400V)	60Hz (460V)	50Hz	60Hz	Metric	Temp. Class		
166.32	-	MVE 1200/075N-60A0	NA	2,652	-	207		0.87	-	1.30	-	2.5	-	M25	135 °C
204.51	-	MVE 1400/075N-60A0	NA	3,263	-	207		0.87	-	1.50	-	2.5	-	M25	135 °C

10 POLES - 600/720 rpm

Unbalance (inlb)		Model		Centrifugal Force (lb)		Weight (lb)		ELECTRICAL SPECIFICATIONS						CERTIFICATE	
								Input Power (Hp)		Nominal Current A max. (Δ)		Ia / In		Cable Gland	Ex II3D
50Hz	60Hz	60Hz		50Hz	60Hz	50Hz	60Hz	50Hz (400V)	60Hz (460V)	50Hz	60Hz	Metric	Temp. Class		
166.32		MVE 2500/10N-60A0		1,698	2,447	207		1.05	1.05	1.40	1.30	1.5	1.5	M25	100 °C
204.51		MVE 3000/10N-60A0		2,088	3,007	229		1.05	1.05	1.40	1.30	1.5	1.5	M25	100 °C

SIZE 60 - MILLING



60Hz masses = 50Hz masses adjusted at 100%



- » II3D Ex tc IIIC Tx IP66
- » Equipment and protective system intended for use in potentially explosive atmospheres (Zone 22) - Directive 2014/34/UE
- » Compliance with Essential Health and Safety Requirements
- » IEC 60079-10-2

L

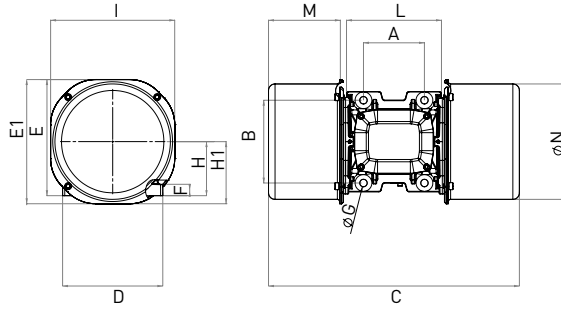

DIMENSIONAL SPECIFICATIONS (inches)

Model		Drawing	Size	C		M	A	B	ØG	Holes	D	E	E1	F	H	H1	I	L	N
50Hz	60Hz			50Hz 60Hz		N°													
				50Hz	60Hz														
MVE 1200/075N-60A0	NA	L	60	22.68	6.50	5.51	7.48	0.67	4	9.06	10.49	11.22	1.02	4.88	5.61	11.22	8.58	10.43	
MVE 1400/075N-60A0	NA	L	60	22.68	6.50	5.51	7.48	0.67	4	9.06	10.49	11.22	1.02	4.88	5.61	11.22	8.58	10.43	

DIMENSIONAL SPECIFICATIONS (inches)

Model		Drawing	Size	C		M	A	B	ØG	Holes	D	E	E1	F	H	H1	I	L	N
60Hz				50Hz 60Hz		N°													
				50Hz	60Hz														
MVE 2500/10N-60A0	L	60	22.68	6.50	5.51	7.48	0.67	4	9.06	10.49	11.22	1.02	4.88	5.61	11.22	8.58	10.43		
MVE 3000/10N-60A0	L	60	22.68	6.50	5.51	7.48	0.67	4	9.06	10.49	11.22	1.02	4.88	5.61	11.22	8.58	10.43		

Notes:

.....

.....

.....

.....

NOTE: Dimensions with coarse degree of accuracy related to UNI 22768/1

This information is provided without warranty, representation, inducement or licence of any kind. It is accurate to the best OLI knowledge or is obtained from sources believed to be accurate. OLI therefore assumes no legal responsibility. The latest and most updated information are available online.



» Declaration of conformity "type B" according to:
2014/35/UE - 2006/42/EC - EN 60034-1

STANDARD

EXPLOSION-PROOF

MILLING

SCREEN VIBRATOR

STAINLESS STEEL



0

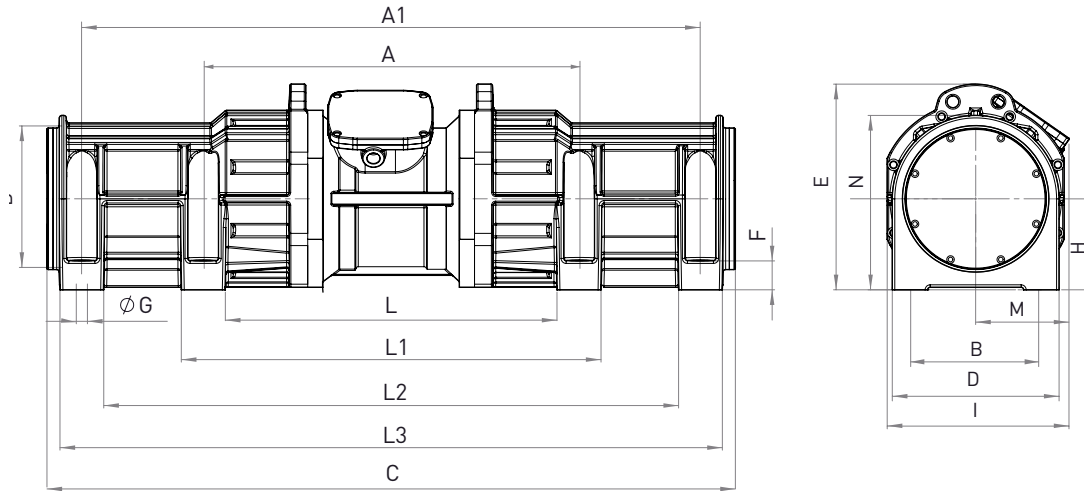

4 POLES - 1500/1800 rpm

Unbalance (inlb)		Model For U.S. Market	Centrifugal Force (lb)		Weight (lb)		ELECTRICAL SPECIFICATIONS						CERTIFICATE			
			50Hz	60Hz	50Hz	60Hz	Input Power (Hp)		Nominal Current A max. (Y)		Ia / In (Ampere)		Cable Gland	Class II Div.2	II 2D	
50Hz	60Hz	60Hz	50Hz	60Hz	50Hz	60Hz	50Hz	60Hz	50Hz	60Hz	50Hz	60Hz		50Hz	60Hz	Temp. Class
121	84	MVE 7700/4N-SV-75A0	7,716	7,721	396.8	374.8	2.9	3.5	4.3	4.3	6.5	6.5	3/4" NPT 110°C	T4	135 °C	
121	84	MVE 7700/4N-SV-75D0	7,716	7,721	396.8	374.8	2.9	3.5	4.3	4.3	6.5	6.5	3/4" NPT 110°C	T4	135 °C	
181	127	MVE 11500/4N-SV-80A0	11,552	11,647	465.2	440.9	3.3	4.0	5.5	5.2	7.1	7.0	3/4" NPT 110°C	T4	135 °C	
269	188	MVE 17100/4N-SV-85A0	17,174	17,308	/	/	4.3	5.1	6.3	6.3	7.1	7.0	3/4" NPT 110°C	T4	135 °C	
269	188	MVE 17100/4N-SV-85A1	17,174	17,308	/	/	4.3	5.1	6.3	6.3	7.1	7.0	3/4" NPT 110°C	T4	135 °C	

SV SIZE 75A0



SV SIZE 85A0



To convert kg into Newton: $N = 9.81 \cdot kg$



M

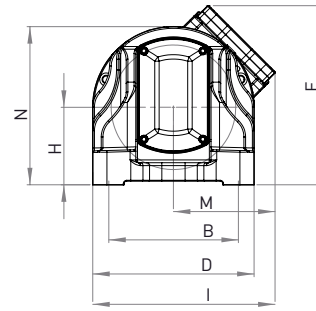
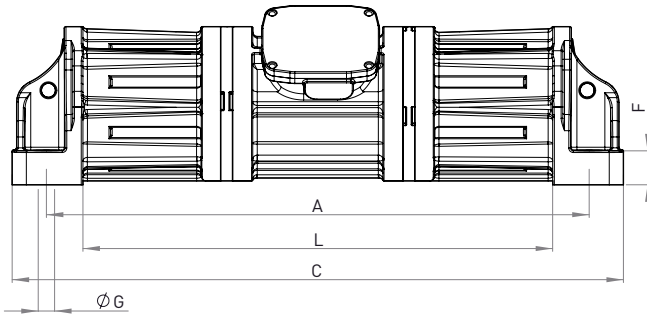

N

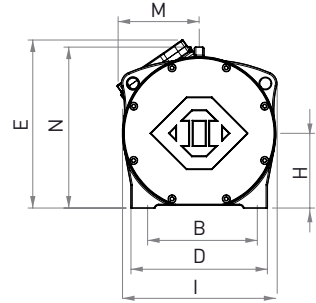
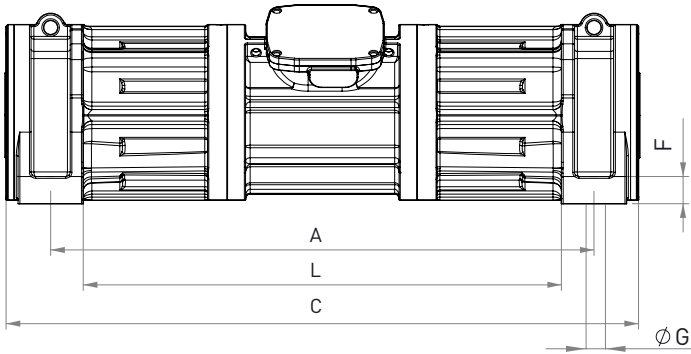

		DIMENSIONAL SPECIFICATIONS (inches)																	
Model For U.S. Market	Drawing	Size	C	M	A	A1	B	ØG	Holes	D	E	F	H	I	L	L1	L2	L3	N
60Hz																			
MVE 7700/4N-SV-75A0	A	75A0	42.52	7.07	37.76	-	9.02	1.14	4	11.22	12.46	2.36	5.39	12.68	32.68	-	-	-	11.00
MVE 7700/4N-SV-75D0	A	75D0	42.52	7.07	37.76	-	9.50	0.79	4	11.22	12.46	2.36	5.39	12.68	32.68	-	-	-	11.00
MVE 11500/4N-SV-80A0	B	80A0	43.94	6.69	37.76	-	9.02	1.14	4	11.22	13.82	1.89	6.14	13.11	33.23	-	-	-	12.44
MVE 17100/4N-SV-85A0	C	85A0	53.62	7.28	31.49	48.19	11.02	0.87	8	12.99	16.02	2.24	7.09	14.17	25.83	32.72	44.76	51.61	13.58
MVE 17100/4N-SV-85A1	C	85A1	53.62	7.28	31.49	48.19	11.41	0.87	8	12.99	16.02	2.24	7.09	14.17	25.83	32.72	44.76	51.61	13.58

Notes:

.....

.....

.....

.....

NOTE: Dimensions with coarse degree of accuracy related to UNI 22768/1

This information is provided without warranty, representation, inducement or licence of any kind. It is accurate to the best OLI knowledge or is obtained from sources believed to be accurate. OLI therefore assumes no legal responsibility. The latest and most updated information are available online.



» Conform to UL1446 and CSA 22.2 No 0-10

STANDARD

EXPLOSION-PROOF

MILLING

SCREEN VIBRATOR

STAINLESS STEEL



4 POLES - 1500/1800 rpm

Unbalance (inlb)		Model	Centrifugal Force (lb)		Weight (lb)		ELECTRICAL SPECIFICATIONS						CERTIFICATE	
			50Hz	60Hz	50Hz	60Hz	Input Power (Hp)		Nominal Current A max. (Y)		Ia / In		Cable Gland	II3D
50Hz	60Hz	60Hz	50Hz	60Hz	50Hz	60Hz	50Hz	60Hz	50Hz (400V)	60Hz (460V)	50Hz	60Hz	Metric	Temp. Class
7.72	5.42	MVE 400/4N-SS-30A0	428	432	40.8		0.16	0.19	0.49	0.50	2.2	2.2	M20	100 °C
20.06	14.04	MVE 1150/4N-SS-40A0	1,111	1,120	65.3		0.47	0.54	1.06	1.09	3.0	2.9	M20	135 °C
28.42	19.68	MVE 1530/4N-SS-50A0	1,574	1,570	59.5		0.83	0.98	1.32	1.20	3.2	3.4	M20	135 °C
28.42	19.68	MVE 1540/4N-SS-50A0	1,574	1,570	59.5		0.83	0.98	1.32	1.20	3.2	3.4	M20	135 °C
44.34	31.01	MVE 2300/4N-SS-50A0	2,456	2,110	104.1		0.86	1.03	1.40	1.35	4.0	4.0	M20	135 °C

6 POLES - 1000/1200 rpm

Unbalance (inlb)		Model	Centrifugal Force (lb)		Weight (lb)		ELECTRICAL SPECIFICATIONS						CERTIFICATE	
			50Hz	60Hz	50Hz	60Hz	Input Power (Hp)		Nominal Current A max. (Y)		Ia / In		Cable Gland	II3D
50Hz	60Hz	60Hz	50Hz	60Hz	50Hz	60Hz	50Hz	60Hz	50Hz (400V)	60Hz (460V)	50Hz	60Hz	Metric	Temp. Class
16.75	11.69	MVE 410/6N-SS-40A0	412	414	61.5		0.20	0.24	0.65	0.62	2.2	2.2	M20	135 °C
45.94	45.94	MVE 1600/6N-SS-50A0	1,131	1,629	101.0		0.74	0.54	0.67	1.15	3.0	2.9	M20	135 °C

8 POLES - 750/900 rpm

Unbalance (inlb)		Model	Centrifugal Force (lb)		Weight (lb)		ELECTRICAL SPECIFICATIONS						CERTIFICATE	
			50Hz	60Hz	50Hz	60Hz	Input Power (Hp)		Nominal Current A max. (Y)		Ia / In		Cable Gland	II3D
50Hz	60Hz	60Hz	50Hz	60Hz	50Hz	60Hz	50Hz	60Hz	50Hz (400V)	60Hz (460V)	50Hz	60Hz	Metric	Temp. Class
16.70		MVE 330/8N-SS-40A0	231	333	65.5		0.31	0.34	1.14	1.14	1.7	1.7	M20	135 °C
42.01		MVE 880/8N-SS-50A0	582	838	101.0		0.34	0.40	0.90	0.89	2.1	2.1	M20	135 °C

SIZE 30A0



SIZE 50A0



4, 6 POLES

60Hz masses = 50Hz masses adjusted at 70%



8 POLES

60Hz masses = 50Hz masses adjusted at 100%

To convert kg into Newton: $N = 9.81 \cdot kg$



- » II3D Ex tc IIIC Tx IP66
- » Equipment and protective system intended for use in potentially explosive atmospheres (Zone 22) - Directive 2014/34/UE
- » Compliance with Essential Health and Safety Requirements
- » IEC 60079-10-2

P

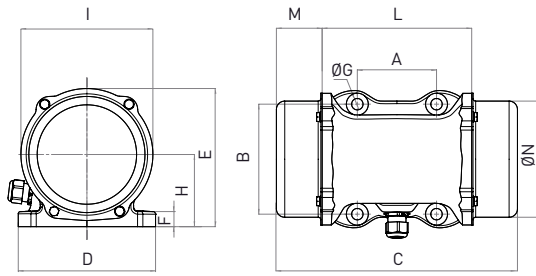

Q

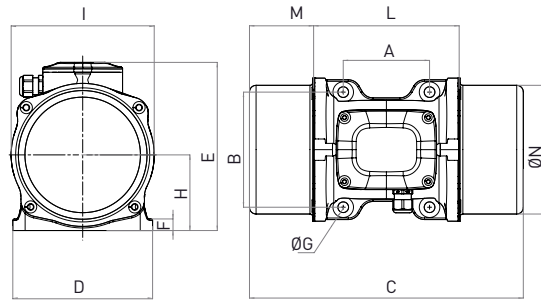

		DIMENSIONAL SPECIFICATIONS (inch)															
Model	Drawing	Size	C		M		A	B	ØG	Holes	D	E	F	H	I	L	N
			50Hz	60Hz	50Hz	60Hz				N°							
MVE 400/4N-SS-30A0	P	30A0	11.73	2.52	3.54	4.92	0.51	4	6.14	6.18	0.67	3.23	5.91	6.46	2.52		
MVE 1150/4N-SS-40A0	Q	40A0	13.11	3.07	4.13	5.51	0.51	4	6.69	8.03	0.55	3.62	6.85	6.85	6.14		
MVE 1530/4N-SS-50A0	Q	50A0	15.28	3.74	4.72	6.69	0.67	4	8.19	8.78	0.71	3.78	7.28	7.76	6.50		
MVE 1540/4N-SS-50A0	Q	50A0	15.28	3.74	4.72	6.69	0.67	4	8.19	8.78	0.71	3.78	7.28	7.76	6.50		
MVE 2300/4N-SS-50A0	Q	50A0	18.03	5.08	4.72	6.69	0.67	4	8.19	8.78	0.71	3.78	7.28	7.56	6.69		

		DIMENSIONAL SPECIFICATIONS (inch)															
Model	Drawing	Size	C		M		A	B	ØG	Holes	D	E	F	H	I	L	N
			50Hz	60Hz	50Hz	60Hz				N°							
MVE 410/6N-SS-40A0	Q	40A0	13.11	3.07	4.13	5.51	0.51	4	6.69	8.03	0.55	3.62	6.85	6.85	6.14		
MVE 1600/6N-SS-50A0	Q	50A0	18.03	5.08	4.72	6.69	0.67	4	8.19	8.78	0.71	3.78	7.28	7.56	6.69		

		DIMENSIONAL SPECIFICATIONS (inch)															
Model	Drawing	Size	C		M		A	B	ØG	Holes	D	E	F	H	I	L	N
			50Hz	60Hz	50Hz	60Hz				N°							
MVE 330/8N-SS-40A0	Q	40A0	13.11	3.07	4.13	5.51	0.51	4	6.69	8.03	0.55	3.62	6.85	6.85	6.14		
MVE 880/8N-SS-50A0	Q	50A0	18.03	5.08	4.72	6.69	0.67	4	8.19	8.78	0.71	3.78	7.28	7.56	6.69		

Notes:

.....

.....

.....

.....

NOTE: Dimensions with coarse degree of accuracy related to UNI 22768/1

This information is provided without warranty, representation, inducement or licence of any kind. It is accurate to the best OLI knowledge or is obtained from sources believed to be accurate. OLI therefore assumes no legal responsibility. The latest and most updated information are available online.

STANDARD

EXPLOSION-PROOF

MILLING

SCREEN VIBRATOR

STAINLESS STEEL



» Conform to UL1446 and CSA 22.2 No 0-10



INSTALLATION

Mounting

The base plate surface where the vibrator motor is mounted has an allowable tolerance of 0.25mm (0.01in), so that the surfaces rest uniformly against each other to avoid internal tension that may cause breakage of the foot of the vibrating motor.

Use 8.8 (grade 5) type bolts, 8.0 type nuts and flat washers belonging to category A EN ISO 7089 / 7092.

The graph below shows the correct torque settings for the different bolt sizes used on the motor vibrators.

Motor / Machine interface

Screw		Washer		Clamping torque	
Metric	Imperial	Metric UNI 6592	Imperial Flat washer	(Nm)	(ftlb)
M6	1/4"	6.4 x 12	1/4"	9	6.5
M8	5/16"	8.4 x 16	5/16"	23	16.5
M10	3/8"	10.5 x 20	3/8"	45	33
M12	1/2"	13 x 24	1/2"	80	58
M16	5/8"	17 x 30	5/8"	185	137
M20	3/4"	21 x 37	3/4"	373	275
M22	7/8"	23 x 39	7/8"	550	411
M24	7/8"	25 x 44	7/8"	696	513
M27	1"	28 x 50	1"	873	645
M36	1-3/8"	37 x 66	1-3/8"	1,864	1,370
M42	1 5/8"	37 x 66	1 5/8"	2,850	2,102

FIXING

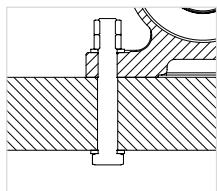

Smooth through borehole
+ screw
+ flat washer
+ nut and counter nut

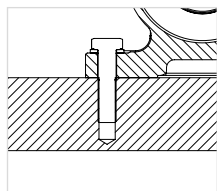

Tapped threaded borehole
+ screw
+ flat washer

SURFACE FLATNESS TOLERANCE

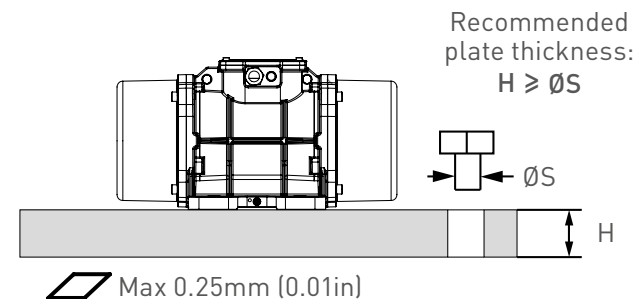

**MACHINED & NOT PAINTED
SUPPORT PLATE**



Electrical connection

Verify that the voltage and frequency supply match the ones indicated on the rating plate of the electric vibrator.

If the motor is operated via a variable frequency drive do not run it under 20 Hz and not over the rated frequency.

Insert the power cable through the cable gland. The lead-in wires have to be of the eyelet-type, pre-insulated, with a bore that suits the terminals of the junction box in order to prevent overheating of the wire. Use only conductors that have a suitable cross-section.

Connect the lead wires to the pins (as shown in the diagram below) and tighten them with the specified torque.

Do not forget to fix the earthing cable to the provided studs → Compulsory connection!

Before closing the junction box make sure that the cover gasket is properly fitted in order to keep the specified IP protection.

For more details on motor installation refer to product manuals.

Junction box nuts tightening torque		
Screw	Nm	ftlb
M4	2.5	1.84
M5	4	2.95
M6	5	3.69
M8	6	4.43
M10	8	5.90

TERMINAL CONNECTIONS

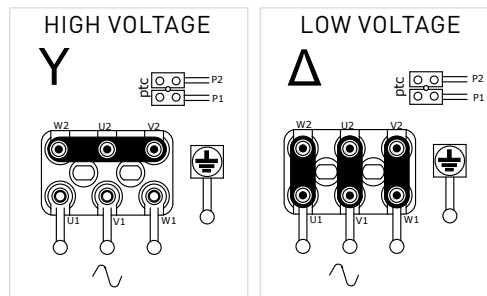

Check "Nominal Current" column label to know the factory preset connection of each motor.

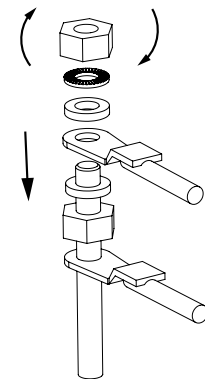

Overload protection

All electric vibrators **MUST** be connected to a suitable external overload protection.

When using two electric vibrators in sync, each of them has to be connected to an external overload protection that must be interlocked to make sure both motors are stopped if one fails.

Always use a thermal-magnetic type motor protection, with delayed cut-off, to avoid stopping

the motor during start-up when the current draw is higher than the rated running current for a few seconds.

Cut-off of the overload protection should be set at a maximum of +10% of the rated current.



HOW TO CHANGE THE VIBRATION INTENSITY

Adjustable masses – Type A

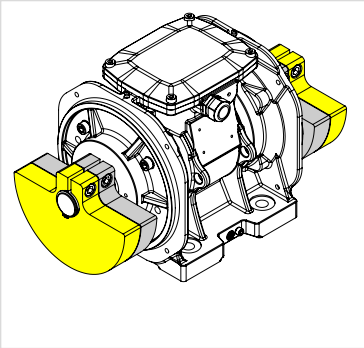

MASSES AT 100%

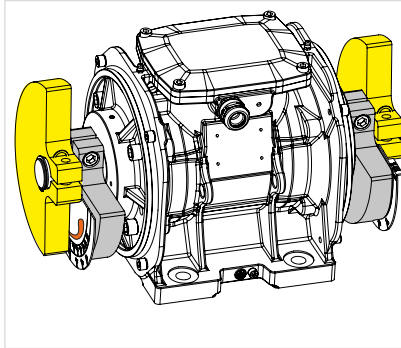

ADJUSTED MASSES

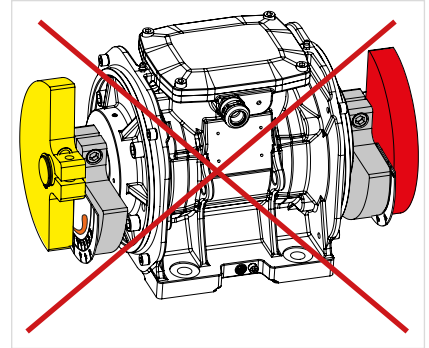

INCORRECTLY ADJUSTED MASSES

2 TIPS TO CORRECTLY ADJUST MASSES:

Rotate the mass following the design on the plate: from the thicker tip towards the thin tip.

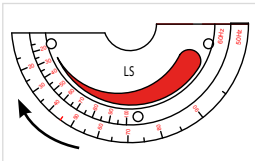

*left side of the motor.
for sizes up to 60*

Rotate the masses in the opposite direction to the cable gland.

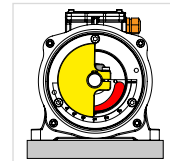

left side

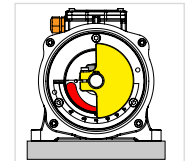

right side

Adjustable masses – Type B

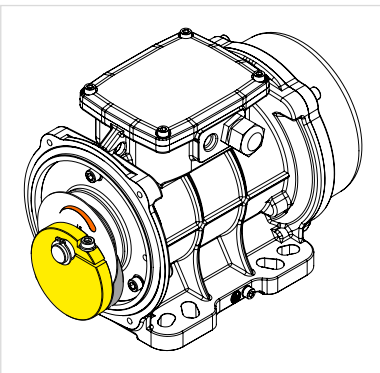

MASSES AT 100%

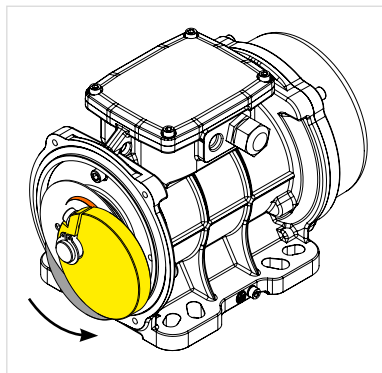

ADJUSTED MASSES

The fissure in the mass indicates the degree of adjustment.

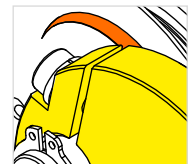

Rotate the mass following the design on the plate: from the thicker tip towards the thin tip.

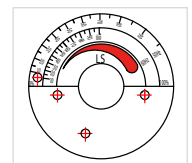

Adjustable masses – Type C (blade masses)

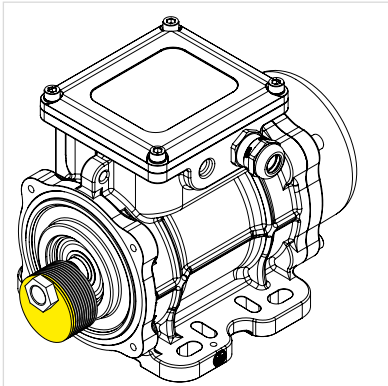

MASSSES AT 100%

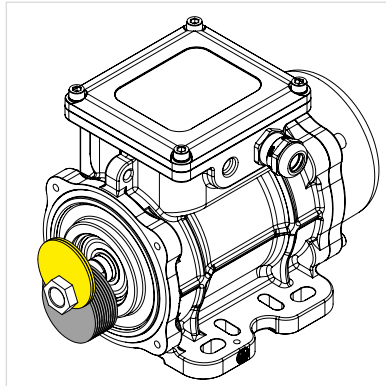

ADJUSTED MASSES

For technical information on the regulation of blade masses refer to the Use and Maintenance Manual.



Warning:
DO NOT grease new motors before installation.

OLI motors with roller bearings leave the factory filled with the right quantity of grease while those with ball bearing do not need any lubrication.

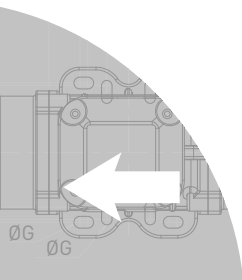

TECHNICAL DRAWINGS

A

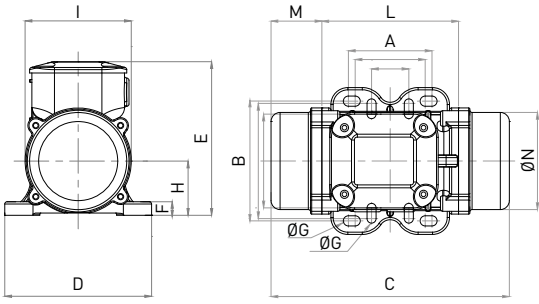

A1

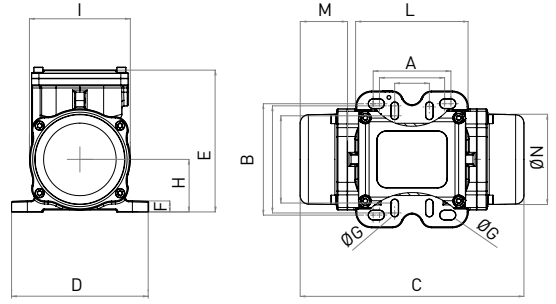

B

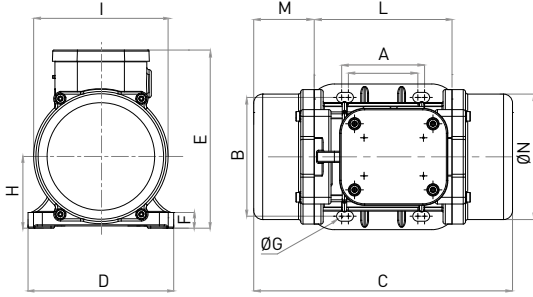

B1

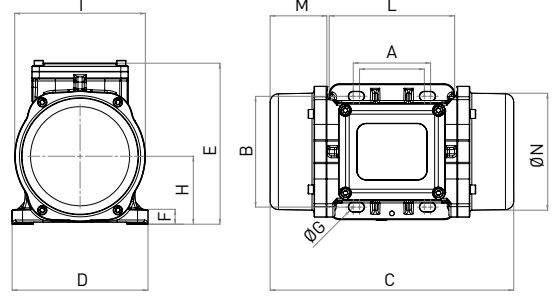

C

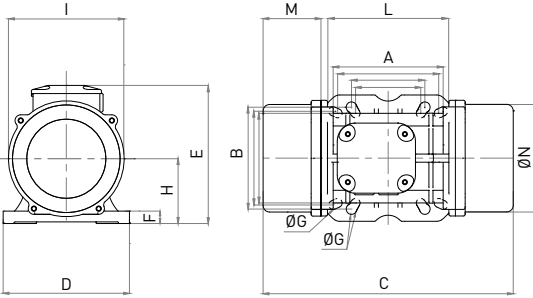

C1

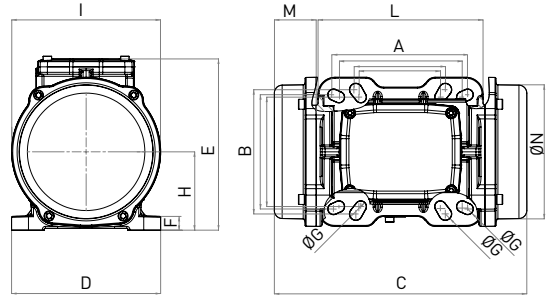

D1

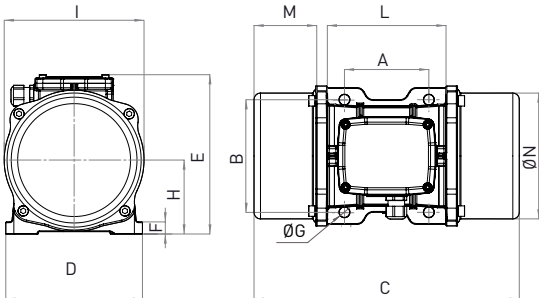

E1

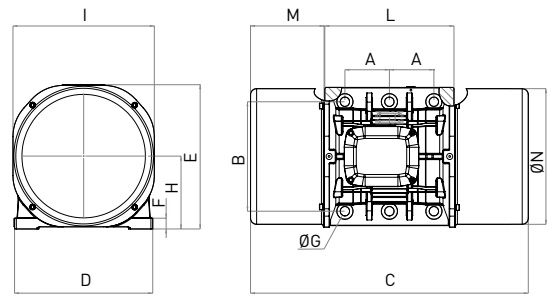

E

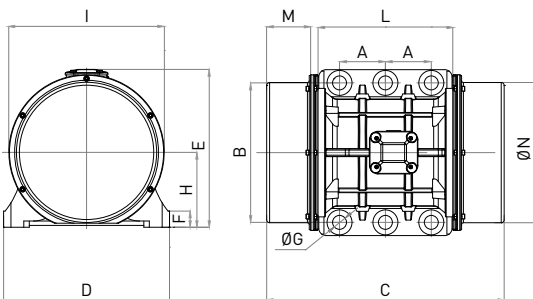

G

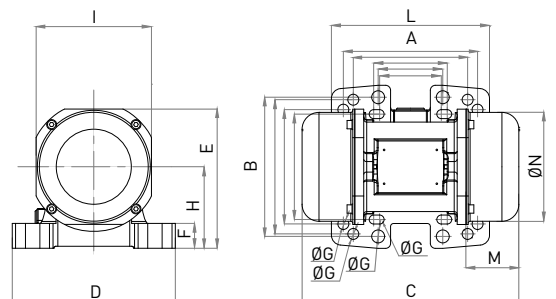

H

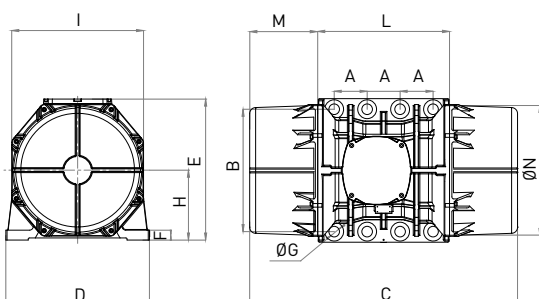

WHEN YOU NEED IT, WHERE YOU NEED IT.

THE WORLDWIDE LEADER IN VIBRATION TECHNOLOGY

WWW.OLIVIBRA.COM



OLI Headquarters

VIA CANALAZZO, 35
41036 MEDOLLA (MO) - ITALY

+39 0535 41 06 11

INFO@OLIVIBRA.COM

OLI U.S.A.

4070 BUFORD HWY STE. 5
DULUTH, GA 30096

770.622.1494

SALES@OLIVIBRA.COM

OLI worldwide

OLI Australia

OLI Benelux

OLI Brazil

OLI China

OLI France

OLI Germany

OLI India

OLI Italy

OLI Malta

OLI Middle East

OLI Nordic

OLI Russia

OLI South Africa

OLI Spain

OLI Thailand

OLI Turkey

OLI UK

OLI USA