

**INNOMOTICS**

A Siemens Business

**Trend-setting Innovation**

# IE5 Permanent Magnet Motors

PM motors with efficiency class IE5 – the pinnacle of internationally recognized efficiency levels and even higher.

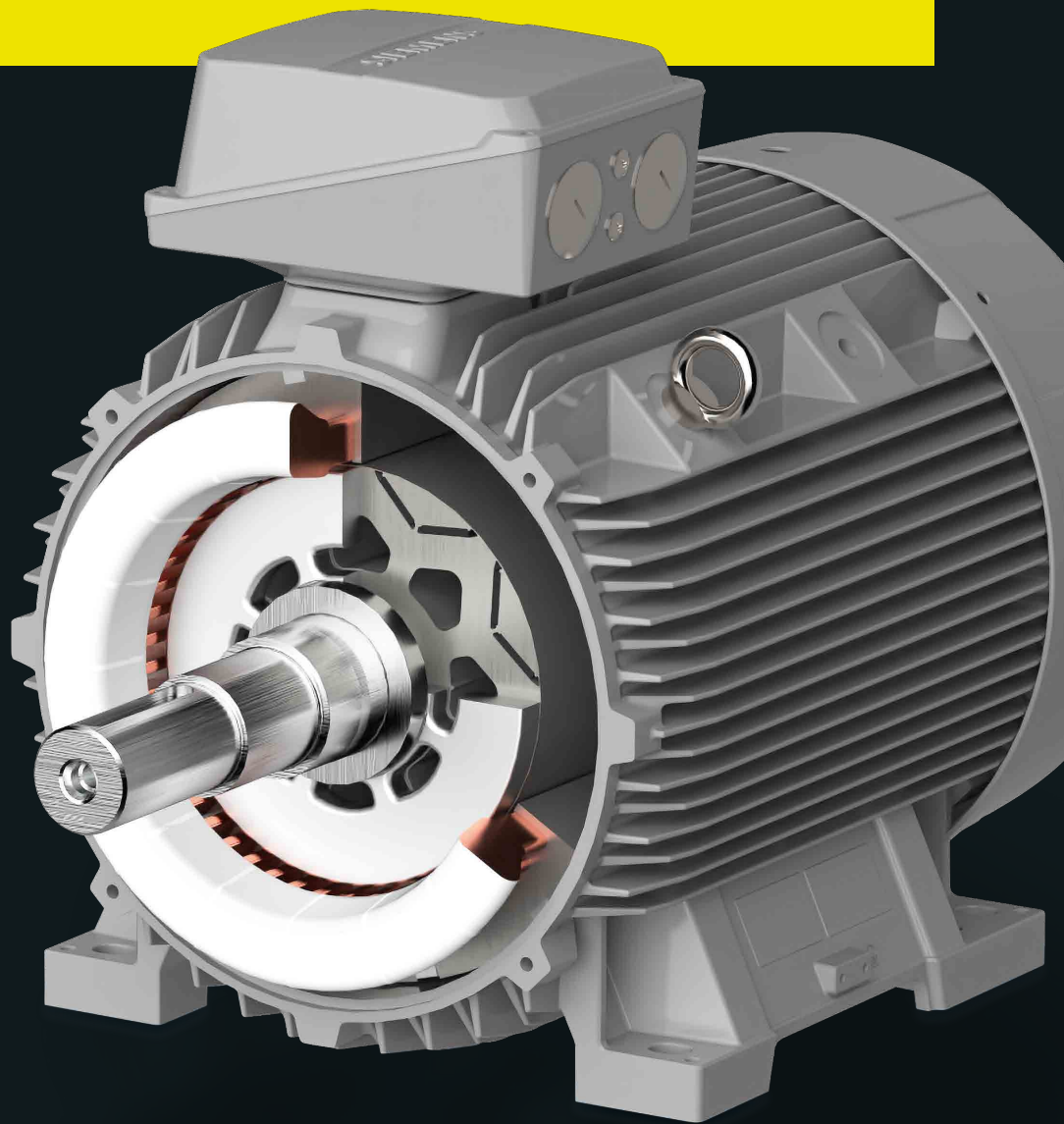

[innomotics.com](http://innomotics.com)

# Permanent Magnet Motors

As global industries strive to achieve sustainable and energy-efficient processes, **Innomotics permanent magnet (PM) motors**, conforming to the **IE5 efficiency class**, represent future-proof and leading-edge drives for motion applications.

The brochure provides an insight into Innomotics' cutting-edge technology. It shows the advantages and customer benefits in a wide range of applications.

## The principle of permanent magnet motors

As the name suggests, permanent magnets represent the core of the motors. These are predominantly fabricated from rare-earth materials which produce a consistent magnetic field. With their integrated magnets, PM motors do not require an electrical current to generate a magnetic field in the rotor, which sets them apart from conventional induction motors. This principle results in the higher efficiency of these types of motors.

## The advantages of permanent magnets

Rare-earth magnets are the driving force behind the high efficiency levels of Innomotics PM motors. These rare-earth magnets have magnetic properties that far surpass those of conventional ferrite magnets. They provide a higher power density, allowing for smaller, lighter and more efficient motors than those using ferrite magnets.

## IE5 efficiency and beyond

Innomotics, a pioneer in motor technology, showcases its commitment to groundbreaking innovation through its PM motors. These motors comply with the IE5 efficiency class – the pinnacle of internationally recognized efficiency levels and even higher.

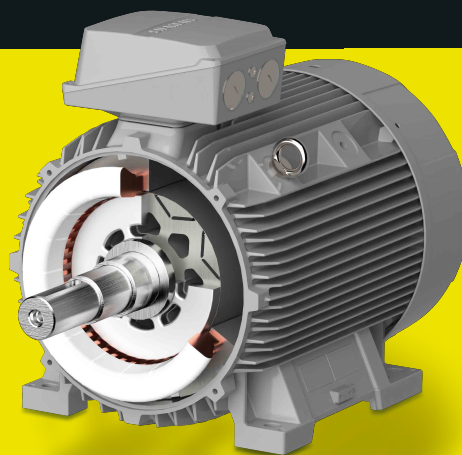

## Key features of our PM motors include:

**High torque and power density:** Based on the innovative design, this motor can deliver the same torque from a smaller frame size when compared to induction motor technology.

### **Unparalleled efficiency:**

Complying with the IE5 efficiency class, these motors set themselves apart as a result of their high energy efficiency. This has a positive impact on operational expenses and the carbon footprint.

**High efficiency in the partial load range:** PM motors are able to deliver significantly higher energy efficiency values in the partial load range and at lower speeds.

### **Reduced weight:**

As a result of the motor design and higher torque density, PM motors tend to weigh less than conventional induction motors with a comparable power rating. This lower weight makes them ideal for applications where the overall weight is a critical factor.

### **Design flexibility:**

The inherent properties of PM motors, such as their compactness and reduced weight, provide machine OEMs with a higher degree of flexibility. This is especially advantageous in applications where space is at a premium and compact motors are required.

### **Wide operating range:**

PM motors are well known for their wide speed range without compromising efficiency and ensuring a high degree of flexibility in addressing various applications.

### **High torque density:**

PM motors offer a higher torque per unit volume compared to many conventional motor designs, facilitating a high performance and compact drive.

### **Enhanced dynamic performance:**

PM motors accelerate and decelerate quickly, making them the obvious choice for applications where speed and direction change rapidly.

### **Cooler operation:**

With no rotor current losses, PM motors frequently operate at cooler temperatures, extending component lifetimes and reducing thermal stress.

# Applications

From individual applications up to large-scale infrastructure projects in industry, the unparalleled efficiency, compactness and superior performance of PM motors make them the obvious choice. Innomotics has PM motors suitable for applications such as material handling, HVAC, water and wastewater, automotive, food processing, textiles – to name just a few. PM motors are not limited to conventional applications, but excel in other demanding use cases, especially where constant torque is required or high power density is a decisive factor.

**The wide field of applications that can be addressed includes the following, for example:**

- Pumps
- Fans
- Blowers
- Compressors
- Cranes
- Conveyor belts
- Extruders
- Mixers

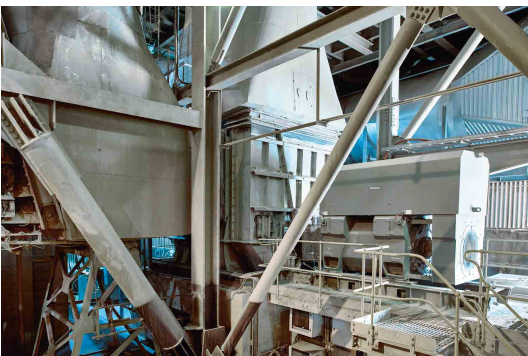

## Design

Innomotics PM motors utilize the 1LE1 induction motor platform, ensuring interchangeability due to the uniformity of mechanical components. One of the outstanding benefits of the 1LE1 platform is its comprehensive range of options, allowing them to be customized to address specific applications.

### Characteristics of Innomotics PM motors:

- Designed for variable speed applications, with a focus on highly efficient operation and rugged torque characteristics.
- Low operating costs prioritized.
- Optimized for operation with Siemens SINAMICS inverters (preferably G120, G220).
- Compatible with all converters supporting PM motor technology.

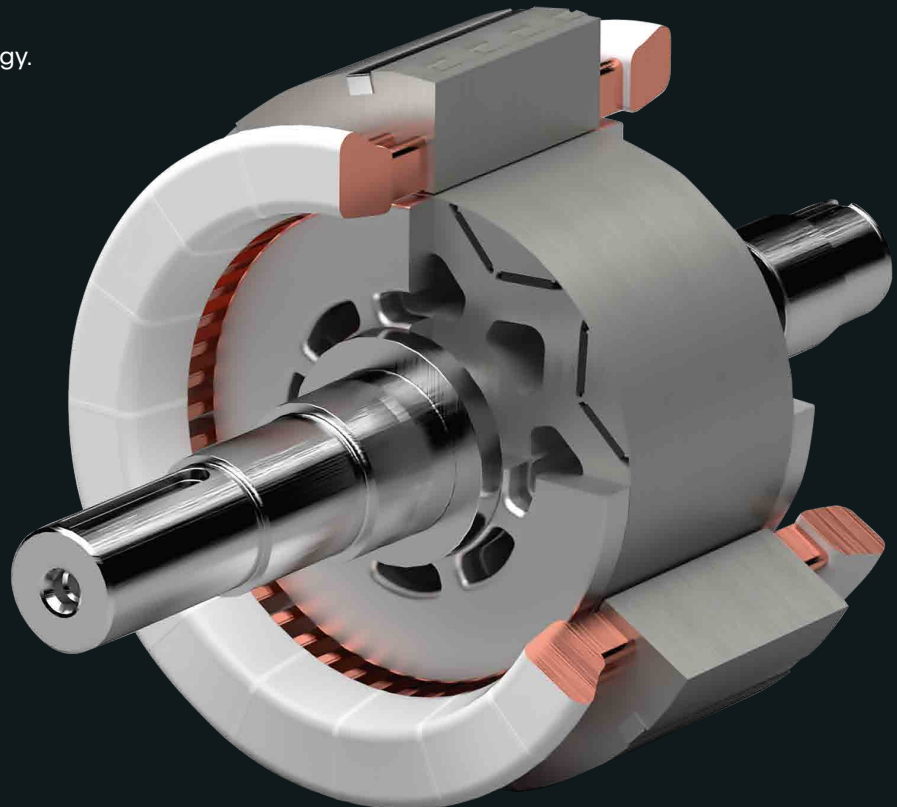

# Technical specifications

- Motor type: 1FZ1
- Operation: converter operation
- Power range: 90 - 250 kW
- Shaft height: 280
- Rated speed: 1500 and 3000 rpm
- Cooling method:  
IC411 (self-ventilation), optionally  
IC416 (forced ventilation)
- Degree of protection: IP55
- Connection type: star
- Vibration level: grade A

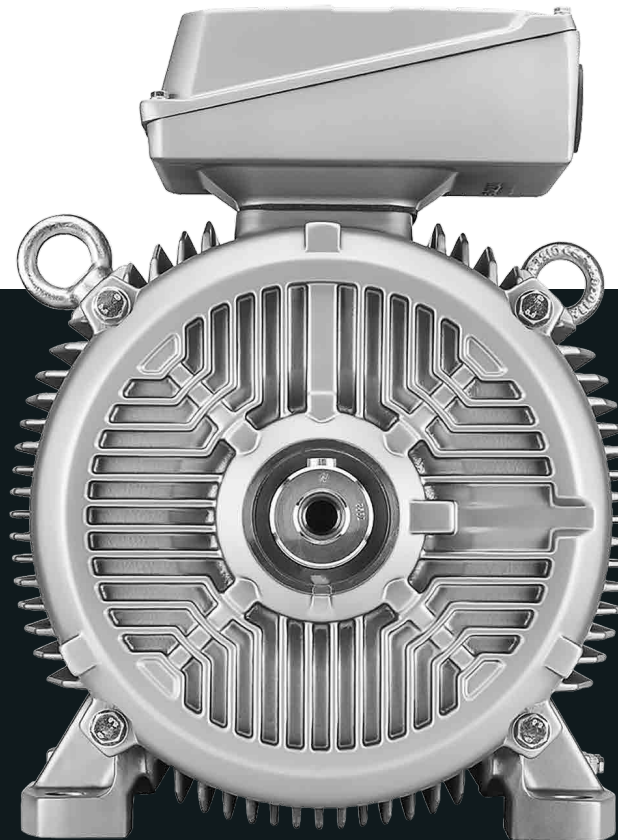

SIEMENS		IE5		CE					
Innomotics GmbH, DE-90441 Nürnberg									
3-MOT 1UV5285K 1FZ15052DK521AB4-Z UD 2022/2345678 001 001									
IEC/EN 60034 280M IMB3 Th.Cl.155(F) -20°C ≤ Tamb ≤ 40°C									
684 kg IP55									
IC411	30 g	6317-C3	CONVERTER DUTY ONLY VPWM						
	30 g	6317-C3	INPUT 380-480V						
	8000 h	UNIREX-N3	Ld 0.42mH						
Nmax 2250 1/min			FREQ 20-150 Hz		Lq 0.96mH				
V	Hz	A	kW	cosφ	Nm	1/min	EFF/%	IE-CL	EMF/V
380 Y	100	270	160	0.93	1019	1500	97.2	IE5 S9	287
Made in Czech Rep.									

## Rating plate

The PM motor rating plate has all the information required to quickly and easily commission a variable speed drive. As is standard for Innomotics motors, the rating plate also provides all the information that is required to identify the motor.

## Torque characteristics

Permanent magnet motors from Innomotics provide a constant torque over a wide speed range extending from 20% up to 100% of the rated speed without requiring forced ventilation. This allows them to be deployed in more applications than were previously possible for comparable induction motors.

Innomotics PM motors have a 180% short overload capability over the complete speed range. For exact speed control when using a SINAMICS inverter, Innomotics PM motors can also operate in sensorless speed range 1:5.

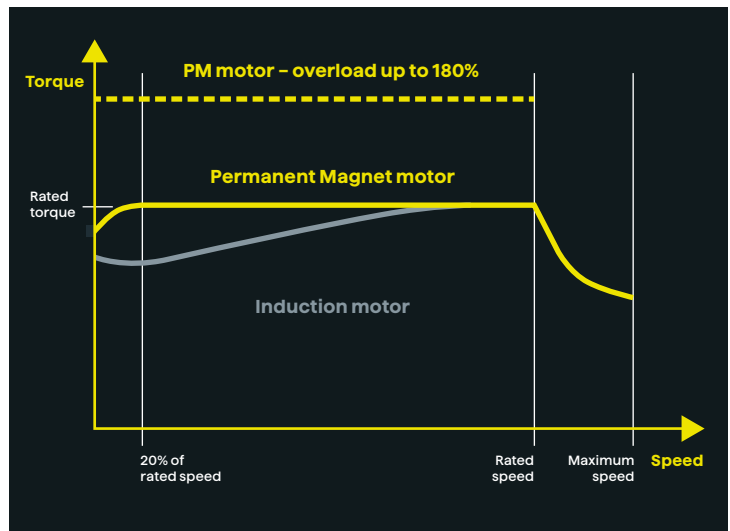

## Efficiency characteristics

Innomotics PM motors comply with IE5 efficiency class standards. When compared to an equivalent induction motor, PM motors consistently have high efficiency values across the entire speed range.

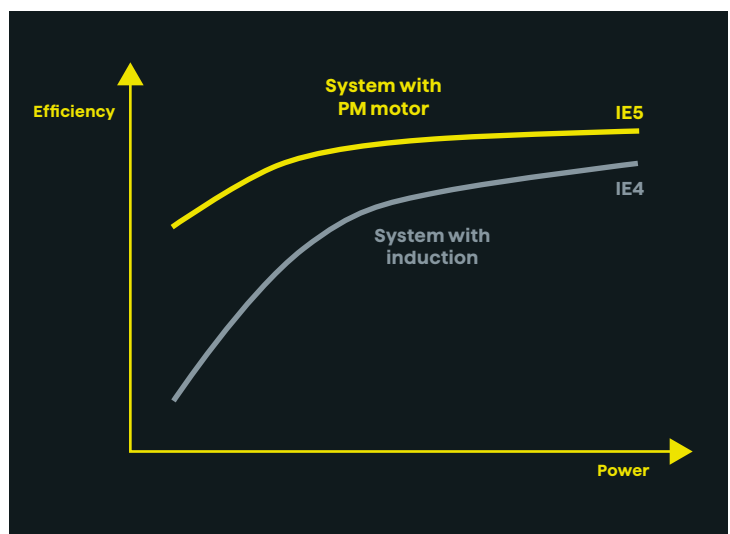

# Motor Features

## Insulation system

PM motors have an advanced insulation system designed for converter operation, ensuring a long winding lifetime without any associated risks.

Admissible voltage peaks:

$$U_{\text{phase-to-phase}} \leq 1600 \text{ V,}$$

$$U_{\text{phase-to-ground}} \leq 1400 \text{ V,}$$

$$t_s > 0.1 \mu\text{s}$$

## Thermal protection

As standard thermal protection of Innomotics PM motors, customers have the option of either selecting 3 PTC or Pt1000 at no additional price.

- 3 PTC – order number at position 15 (letter B)
- 1 Pt1000 – order number at position 15 (letter K)

Innomotics offers several other thermal protection options, safeguarding the motor winding against overheating due to phase loss, overload or voltage fluctuations, including undervoltage and overvoltage conditions.

## Bearing current protection

All PM motors in the SH280 series from Innomotics have insulated NDE bearings as standard. This ensures a longer motor bearing system service life, while also allowing standard bearings to be used instead of hybrid bearings. This design reduces maintenance costs over the motor's lifetime.

## Control methods

The introduction of permanent magnet motors, characterized by their higher efficiency and power density, has led to new possibilities regarding motor control. When teamed up with variable speed drives (VSD), these motors offer unparalleled precision and versatility.

### **Vector control (field-oriented control):**

Vector control, also known as field-oriented control (FOC), provides more precise motor torque and speed control. By decoupling the motor's torque-producing current from the magnetizing current, FOC allows the torque and flux to be independently controlled, thereby providing more precise control dynamics.

Smooth operation without an encoder is inherently possible.

**Applications:** Ideally suited for applications demanding fast torque changes and high precision.



## Values valid for a rated motor voltage of 380V (voltage code 2-1)

Order number	Rated power [kW]	Rated torque [Nm]	Rated current [A]	Rated power factor	Efficiency [%]	Maximum speed [rpm]	Maximum torque/ rated torque	bEMF at rated speed (20°C) [V]	Moment of inertia [kg/m²]	Weight [kg]	Efficiency class
<b>3000 rpm</b>											
1FZ1505-2DL32-1...	110	350	174	0.99	96.8	3600	1.8	370	0.84	443	IE5
1FZ1505-2DL42-1...	132	420	210	0.98	96.9	3600	1.8	361	1.01	486	IE5
1FZ1505-2DL52-1...	160	509	252	0.99	97.0	3600	1.8	389	1.29	529	IE5
1FZ1505-2DL62-1...	200	637	315	0.99	97.2	3600	1.7	371	1.57	617	IE5
1FZ1505-2DL72-1...	250	796	410	0.95	97.2	3600	1.7	369	2.02	709	IE5
<b>1500 rpm</b>											
1FZ1505-2DK22-1...	90	573	155	0.91	96.9	2250	1.8	308	1.31	536	IE5
1FZ1505-2DK32-1...	110	700	189	0.91	97.0	2250	1.7	307	1.49	579	IE5
1FZ1505-2DK42-1...	132	840	225	0.92	97.1	2250	1.7	317	1.67	643	IE5
1FZ1505-2DK52-1...	160	1019	270	0.93	97.2	2250	1.6	287	1.85	684	IE5
1FZ1505-2DK62-1...	200	1273	340	0.92	97.4	2250	1.5	312	2.03	719	IE5

# Dimensions

## IM B3 type of construction

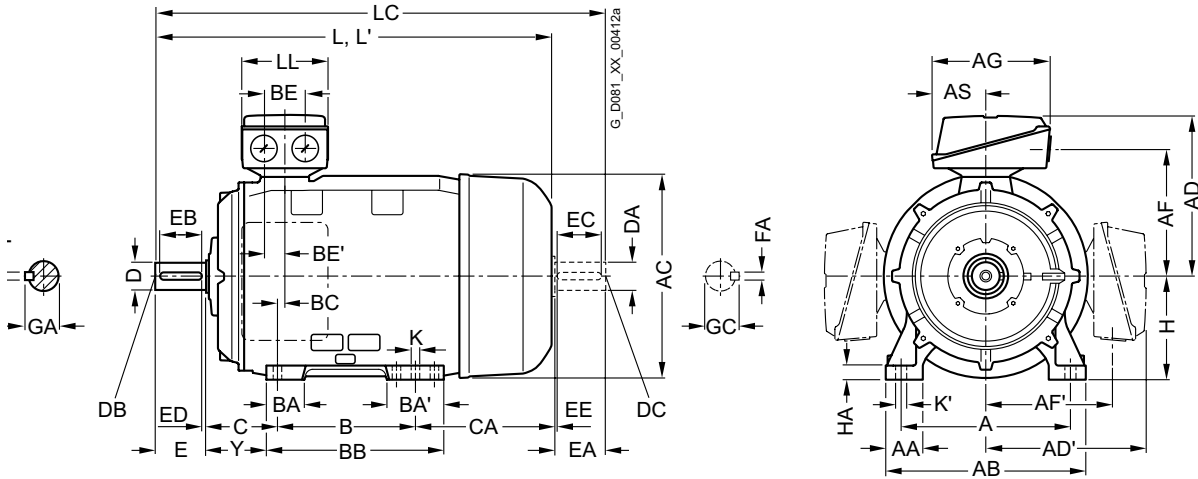

## IM B5 and IM V1 types of construction

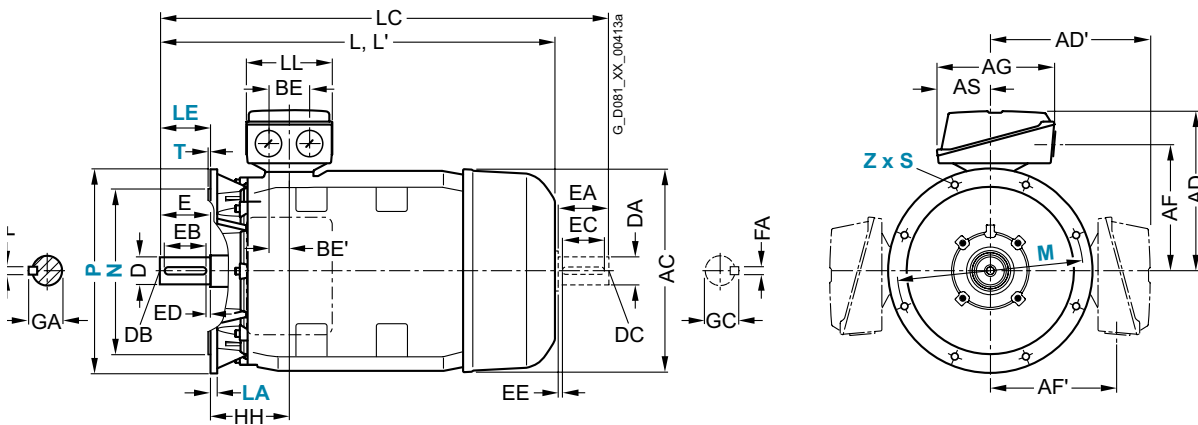

## IM B35 type of construction

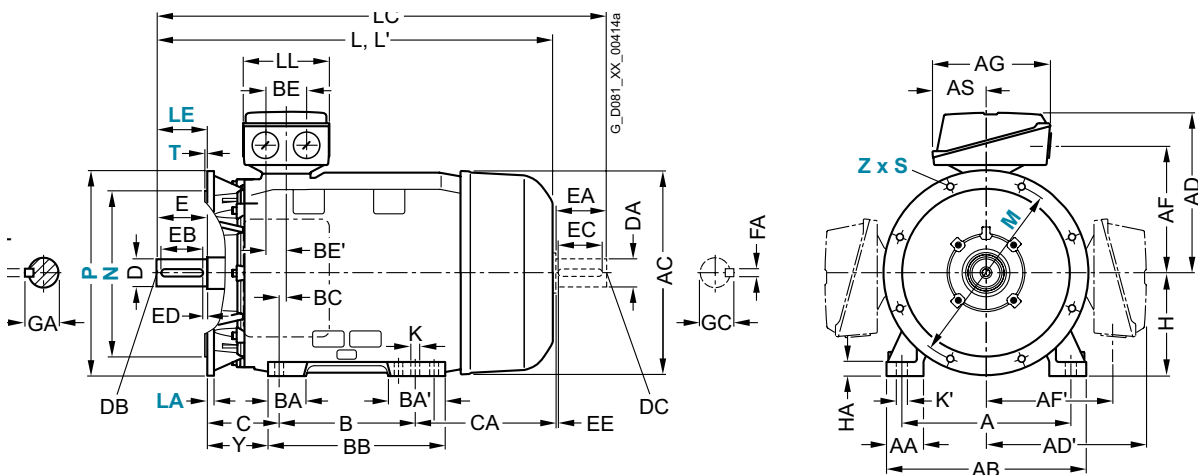

## Dimension designation acc. to IEC

Rated speed [rpm]	Rated power [kW]	Motor type	[mm]																								
			A	AA	AB	AC	AD	AD'	AF	AF'	AG	AS	B	BA	BA'	BB	BC	BE	BE'	C	CA	H	HA	Y	HH	K	K'
3000	110	1FZ1505-2DL3	457	100	540	551	433	433	345	345	319	145	368	101	152	479	20	110	55	190	267	280	40	160	210	24	30
3000	132	1FZ1505-2DL4	457	100	540	551	527	527	417	417	374	164	368	101	152	479	20	110	55	190	267	280	40	160	210	24	30
3000	160	1FZ1505-2DL5	457	100	540	551	527	527	417	417	374	164	368	101	152	479	20	110	55	190	267	280	40	160	210	24	30
3000	200	1FZ1505-2DL6	457	100	540	551	527	527	417	417	374	164	368	101	152	479	20	110	55	190	267	280	40	160	210	24	30
3000	250	1FZ1505-2DL7	457	100	540	551	527	527	417	417	374	164	368	101	152	479	20	110	55	190	267	280	40	160	210	24	30
1500	90	1FZ1505-2DK2	457	100	540	551	433	433	345	345	319	145	368	101	152	479	20	110	55	190	267	280	40	160	210	24	30
1500	110	1FZ1505-2DK3	457	100	540	551	433	433	345	345	319	145	368	101	152	479	20	110	55	190	267	280	40	160	210	24	30
1500	132	1FZ1505-2DK4	457	100	540	551	527	527	417	417	374	164	368	101	152	479	20	110	55	190	267	280	40	160	210	24	30
1500	160	1FZ1505-2DK5	457	100	540	551	527	527	417	417	374	164	368	101	152	479	20	110	55	190	267	280	40	160	210	24	30
1500	200	1FZ1505-2DK6	457	100	540	551	527	527	417	417	374	164	368	101	152	479	20	110	55	190	267	280	40	160	210	24	30
Rated speed [rpm]	Rated power [kW]	Motor type	[mm]																								
			L	LA	LC	LE	LL	D	DB	E	EB	ED	F	GA	DA	DC	EA	EC	EE	FA	GC	M	N	P	S	T	Z
3000	110	1FZ1505-2DL3	960	18	1105	140	233	65	M20	140	125	10	18	69	60	M20	140	125	10	18	64	500	450	550	15,8	5	8
3000	132	1FZ1505-2DL4	960	18	1105	140	299	65	M20	140	125	10	18	69	60	M20	140	125	10	18	64	500	450	550	15,8	5	8
3000	160	1FZ1505-2DL5	960	18	1105	140	299	65	M20	140	125	10	18	69	60	M20	140	125	10	18	64	500	450	550	15,8	5	8
3000	200	1FZ1505-2DL6	1070	18	1215	140	299	65	M20	140	125	10	18	69	60	M20	140	125	10	18	64	500	450	550	15,8	5	8
3000	250	1FZ1505-2DL7	1070	18	1215	140	299	65	M20	140	125	10	18	69	60	M20	140	125	10	18	64	500	450	550	15,8	5	8
1500	90	1FZ1505-2DK2	960	18	1105	140	233	75	M20	140	125	10	20	79,5	65	M20	140	125	10	18	69	500	450	550	15,8	5	8
1500	110	1FZ1505-2DK3	960	18	1105	140	233	75	M20	140	125	10	20	79,5	65	M20	140	125	10	18	69	500	450	550	15,8	5	8
1500	132	1FZ1505-2DK4	1070	18	1215	140	299	75	M20	140	125	10	20	79,5	65	M20	140	125	10	18	69	500	450	550	15,8	5	8
1500	160	1FZ1505-2DK5	1070	18	1215	140	299	75	M20	140	125	10	20	79,5	65	M20	140	125	10	18	69	500	450	550	15,8	5	8
1500	200	1FZ1505-2DK6	1070	18	1215	140	299	75	M20	140	125	10	20	79,5	65	M20	140	125	10	18	69	500	450	550	15,8	5	8

# reliable motion for a better tomorrow

Looking for more information?  
Check out these web sites:

[innomotics.com](https://innomotics.com)

[portal.innomotics.com](https://portal.innomotics.com)

[siemens.com/spc](https://siemens.com/spc)



**Publisher information:**

Innomotics GmbH, Vogelweiherstr. 1 – 15, 90441 Nuremberg,  
Germany

Printed in Germany

© Innomotics 2023

This brochure contains the Siemens logo and the Siemens legal information. Please note that since July, 1<sup>st</sup>, 2023, the Siemens business units Large Drives Applications and Low Voltage Motors are part of Innomotics GmbH, Germany.

All rights to the product information in this brochure have been transferred from Siemens to Innomotics. The document will be rebranded in due course.