



# MAGNET TECHNOLOGY

EN





### KEB AUTOMATION KG

All our efforts are directed towards the development, production and application of electromagnetic technology throughout our extensive range of brakes and clutches.

The functions, **starting, stopping, positioning and safe holding** of moving axes in machines and plant call for reliably designed and safely functioning components.

With our advanced manufacturing techniques we are able to produce high quality, high-grade products, and through our continued investment we now have manufacturing plants worldwide. We have the ability to produce high volume stock parts or ones that are tailored specifically to your requirements.



## SAFE BRAKING AND HOLDING

**COMBISTOP H**



**COMBISTOP D**



**COMBISTOP T**



**COMBISTOP**

... starting from page 4

Electromagnetically actuated dual-surface spring applied DC brakes for dry operation.

**COMBISTOP N**

**COMBIPERM P1**

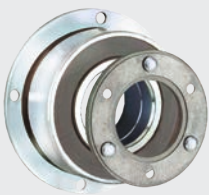

**COMBIPERM PC**



**COMBIPERM P1**



**COMBIPERM**

... starting from page 16

Permanent magnet brakes and clutches for dry operation.

## SWITCHING, STOPPING, POSITIONING

**COMBINORM C**



**COMBINORM B**



**COMBINORM K**



**COMBINORM**

... starting from page 22

electromagnetic-actuated open-circuit operated clutches and brakes without slip rings.

**COMBIBOX**

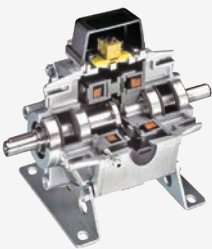

**COMBIBOX**

... starting from page 36

a ready to be installed electromagnetic-actuated clutch-brake-module

## POWER SUPPLY / SWITCHGEAR

**COMBITRON 91**



**COMBITRON 98**



**COMBITRON 94**



**COMBITRON**

... starting from page 44

DC-supply from the alternating voltage supply system and electronic switches for electromagnetic clutches and brakes.

# COMBISTOP PROGRAM SCHEDULE

COMBISTOP are electromagnetically actuated dual surface spring-applied DC brakes for dry application. The braking force is applied by the springs and released through the electromagnetic force. These brakes are successfully working in the most demanding applications and are used wherever rotating masses must be stopped or shafts need to held in a precise position.

High quality materials together with high precision manufacturing, process inspections and functional testing guarantee reliable, safe operation.

On request we can design the COMBISTOP brake to your requirements, for example the brake can be supplied with pre-mounted armature and increased torque.

Please bear in mind that the rated torques are achieved after a required running-in process.

- certified to 

## PROGRAM SCHEDULE

### COMBISTOP ELECTROMAGNETICALLY ACTUATED DUAL-SURFACE SPRING APPLIED DC BRAKES

Mini brake	0.3 ... 2 Nm	Page 5	<b>COMBISTOP M</b>
Holding brake for dynamic demands	2 ... 1,000 Nm	Page 6	<b>COMBISTOP N</b>
Holding brake for static application	5 ... 1,500 Nm	Page 6	<b>COMBISTOP H</b>
Holding brake for protection class IP 65	5 ... 250 Nm	Page 8	<b>COMBISTOP T</b>
Double-brake for theatre, lift and elevators	2 x 5 ... 2 x 1,000 Nm	Page 10	<b>COMBISTOP D</b>
Hoisting brakes, elevator brakes D8	2 x 25 ... 2 x 125 Nm	Page 10	<b>COMBISTOP L</b>
Accessories		Page 12	

## TECHNICAL DATA

Switching times	Page 15
Dimensions / Calculation	Page 50
Legend	Page 51

## ACCESSORIES

COMBISTOP	M	N	H	T	D	L
Friction disk		x	x		x	X
Flange	x	x	x	x	x	X
Friction disk with collar		X	X			
Dust protection ring		x	x		x	
Micro switch		x	x		x	X
Hand release	x	x	x	x		x
TERMINAL BOX		X	X	X	X	X

stands for MINI Brake, the small compact solution with torques up to 2 Nm. The brake is characterized by a particular compact construction, it is designed for small loads and holding functions without torque adjustment and adjustability and available with or without hand release.

**Range of application:**

e.g. general machine building, small-power motors, automation technique, apparatus engineering.

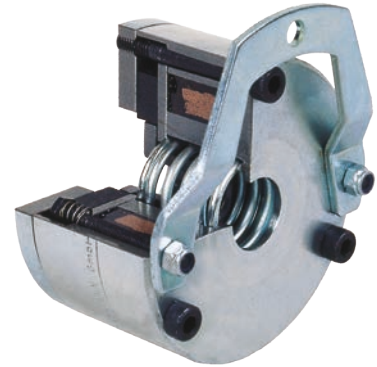

SIZE	$T_{2N}^{1)}$ [Nm]	$P_{20}$ [W]	A	B	D	F	G	H	K	N	O	P	T	U	V	W	X	$a_1$	$b_1$	c	e	g	$m^{3)}$	$\alpha^\circ$	weight [kg]
0B08	0.3	6		34	5	8.3	23	5.5		9.8	14.7	3.5		30	40	0.1						4.7			0.15
0008	0.5-2	11-15	59.5	52	10 <sup>2)</sup>	14	29.5	0.5-1	4.5	16	18	4.3	5	43.5	26	59.5	0.15	41	36.5	2	7	5.5	0.8	7	0.4

All dimensions in mm keyway according to DIN 6885/1 according to VDE 0580, isolation class „B“ <sup>1)</sup> rated torque after running in process

<sup>2)</sup> bore tolerance max  $\varnothing$  10 mm H7, otherwise H8 <sup>3)</sup> Mounting dimension „m“ with attracted armature

**COMBISTOP M**

**0B08110 ... without hand release**

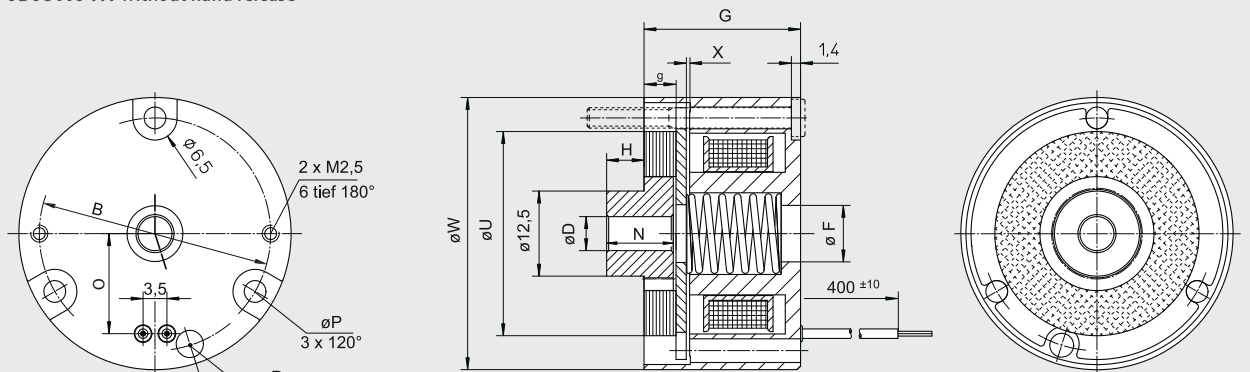

**COMBISTOP M**

**0008110 ... without hand release**

**0008110 ... with hand release**

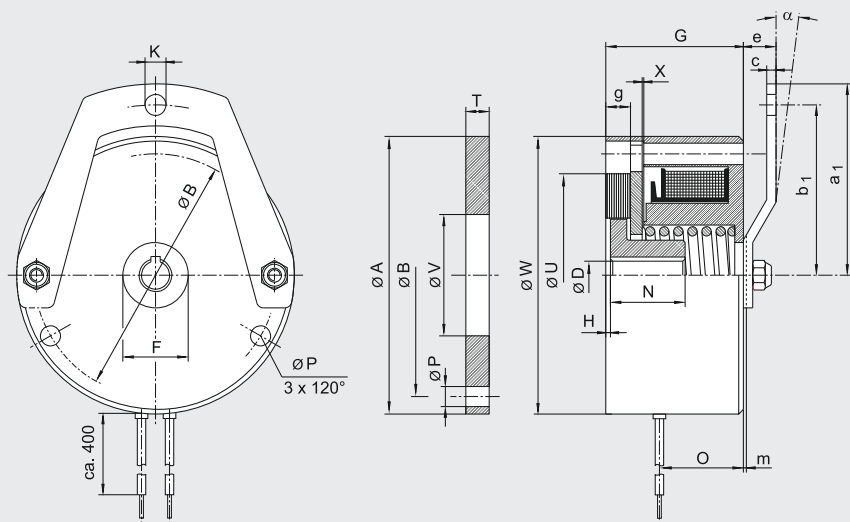

Accessories **COMBISTOP M**

- flange

# COMBISTOP N AND H

COMBISTOP **N** and **H** are the standard series of dual-surface spring-applied brakes in two designs:

- dynamic applications with continuous stress
  - static applications with short-term stress
- COMBISTOP N**  
**COMBISTOP H**

## COMBISTOP N:

- Rated torque in the range 5 ... 1000 Nm
- designed for dynamic applications with regular brake applications at high speed!

## Range of application:

e.g. brake motors, geared brake motors, wind energy plants, refrigerated warehouses

## Option:

- Cold Climate Version CCV (-40 ... +60 °C)
- ISO-class F + H

## Accessories COMBISTOP N

- Friction disc
- Flange
- Friction disc with collar (up to size 06)
- Duats protection ring
- Micro switch

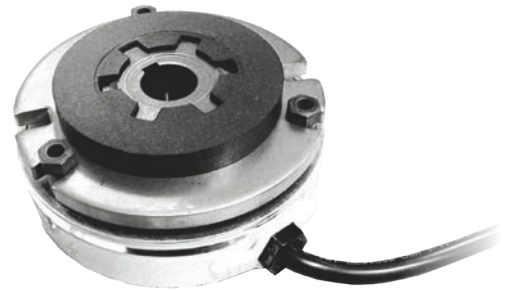

**COMBISTOP N** - dynamic operation

**COMBISTOP H** - static operation

.. 3811**X**.. without hand release

.. 3813**X**.. with hand release

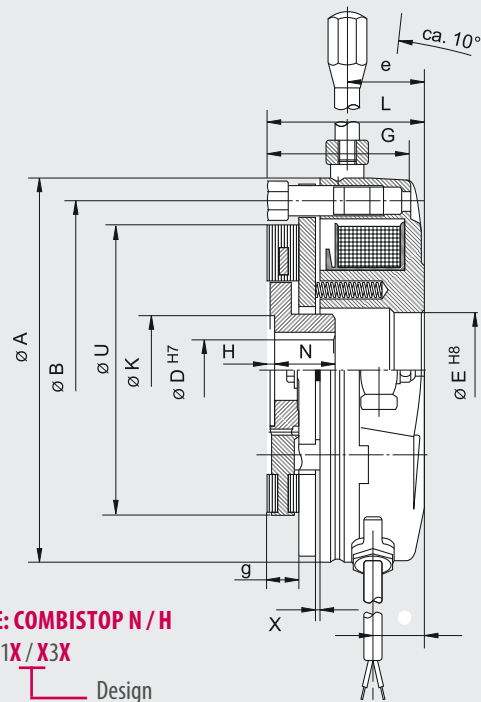
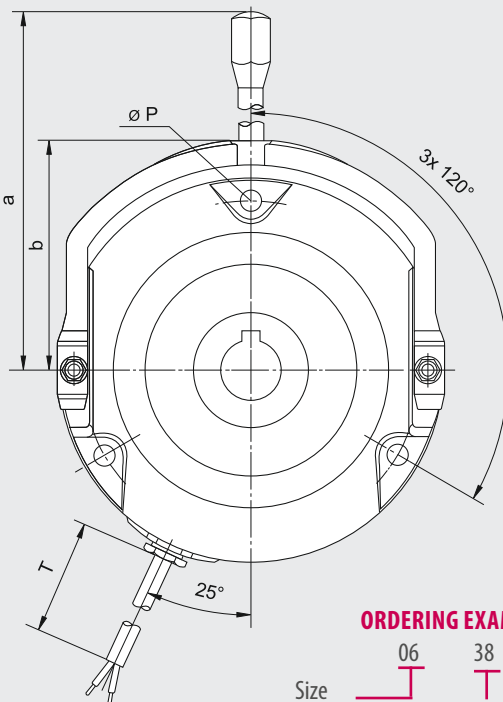

## ORDERING EXAMPLE: COMBISTOP N / H

Size 06 38 11X/X3X Design  
Type  
VDC, Ø D ?

SIZE	Version „N“		Version „H“		A	B	H7 Ø D max.	E	G	H	K	L	N	O	P	T	U	X	a	b	e	g	weight kg
	T <sub>2N</sub> <sup>1)</sup>	P <sub>20</sub>	T <sub>2N</sub> <sup>1)</sup>	P <sub>20</sub>																			
	Nm	W	Nm	W																			
02	5	25	7,5	25	85	72	15**	22	34,2	1-1,5	22	37,7	18	11,5	3x4,5	500	60	0,2	105,5	53,5	23	7,5	1
03	10	30	15	30	102	90	20	32	37,2	2-2,5	31	41,7	20	13	3x5,5	500	77	0,2	113	62	25,5	8	1,5
04	20	30	30	30	127	112	25	38	47,2	2-2,5	37	51,7	20	16,5	3x6,5	500	96	0,2	128	76	26,2	10,5	3
05	36	48	50	48	147	132	30	42	52,7	2,5-3	42	57,7	25	18,5	3x6,5	500	115	0,2	168	86	30,5	12	4,5
06	70	62	90	75	164	145	35**	47	59,8	2,5-3	42	68,8	30	20	3x9	500	115	0,3	176	96	39,5	12	7
07	100	65	150	90	190	170	45	62	68	3	57	75,5	30	21,5	3x9	750	149	0,3	225	115	41	14	10
08	150	75	225	90	218	196	60	78	80	4,5	57/76*	*87,4	35	27	3x9	750	175	0,4	235	125	46,5	16	16
09	250	80	375	115	253	230	60	97	88,2	5	76	101,7	40	28	3x11	750	206	0,4	256	146	56	18	26
10	500	130	750	180	307	278	75	120	98,8	9,5	92	110,8	50	25	6x11	750	252	0,5	335	175	59	22	39
11	1000	180	1500	280	363	325	90	140	122,1	-	-	134,5	100	30,5	6x13	1000	300	0,6	***	***	***	30	80

All dimensions in mm keyway according to DIN 6885/1 Standard voltage 24 / 105 / 180 / 205 V DC according to VDE 0580, isolation class „B“, 100% on time, Type of protection IP40, with dust protection ring IP44

<sup>1)</sup> rated torque after running in process \* hub bore > ø 45 \*\* keyway according to DIN 6885/3 \*\*\* mech. release with hexagon screw

**COMBISTOP H:** Rated torque in the range 7.5... 1500 Nm - designed for static applications, i.e. braking from low speeds and secure holding of loads!

### Range of application

e.g. electronically controlled or regulated drives, wind energy plants, refrigerated warehouses

### Accessories **COMBISTOP H**

- Friction disk
- Flange
- Friction disc (up to size 06)
- Dust protection ring
- micro switch



# COMBISTOP T

A brake design which are always used whenever the application puts higher demands on the protection class.

## COMBISTOP T:

the IP 65-brake with identical hole circle such as COMBISTOP N and H, optionally completely closed on the backside or prepared for the attachment of tacho-generators or shaft sealing ring.

### Range of application:

e.g. general machine building, crane construction, ship gear, wind energy plants, refrigerated warehouses

## COMBISTOP T

- ..28G10** standard version without hand release
- ..28G20** standard version with hand release
- ..28G1T** for tacho-generators without hand release
- ..28G2T** for tacho-generators with hand release
- ..28G1W** for shaft sealing ring without hand release
- ..28G2W** for shaft sealing ring with hand release

SIZE	T <sub>2N</sub> <sup>1)</sup> [Nm]	P <sub>20</sub> [W]	øA <sub>1</sub>	øA h8 H8	øB	C	øD max.	øE	øE <sub>1</sub>	øF	øG	H	øK	L	M	M <sub>1</sub>	N	O
02	5	25	102	98	72	34	15**	50	85	94.5	88	1-1.5	22	39	2.4	88 x 3	18	11
03	10	30	123	118	90	37	20	64	102	116	109.5	2-2.5	31	42.8	2.4	110 x 3	20	12.5
04	20	30	148	143	112	47	25	80	127	138.5	132	2-2.5	37	52.8	2.4	132 x 3	20	16
05	36	48	170	165	132	51.5	30	102	147	158.5	152	2.5-3	42	58.3	2.4	152 x 3	25	17
06	70	62	186	180	145	60	35**	115	164	176.5	170	2.5-3	42	68.8	2.4	170 x 3	30	20
07	100	65	216	210	170	68	45	144	193	200.5	196	2.0	57	74.2	3.5	196 x 4	30	20
08	150	75	246	240	196	77	60	160	217	235.5	225	4.5	57 76*	88	3.2	225 x 4	35	25
09	250	80	280	276	230	86	60	180	254	272	260	5.0	76	102	3.5	260 x 5	40	33

SIZE	øP	øP <sub>1</sub>	øP <sub>2</sub>	R	T	øV	X	a <sub>1</sub>	b <sub>1</sub>	ød	e	sw	øf	øg	s	k	L <sub>1</sub>	I
02	4.5	8	M4	0.5	6	37	0.2	105.5	53.5	8	22.5	11	22	34	4 x M4	10	36.5	44
03	5.6	10	M5	1.5	7	48	0.2	114	62	8	24	11	32	40	4 x M5	12	40.1	52
04	6.5	11	M6	1.5	9	60	0.2	128	76	8	25.7	11	38	54	4 x M5	12	50.1	66
05	6.5	11	M6	2	9	70	0.2	166	86	10	28	14	42	64	4 x M5	12	56.1	76
06	9	15	M8	2	11	70	0.3	176	96	10	40	14	47	75	4 x M5	12	65.5	88
07	9	15	M8	3.0	12	75	0.3	225	115	14	40	17	62	85	4 x M6	15	73	100
08	9	15	M8	3.5	14	95	0.4	235	125	14	45	17	78	100	4 x M6	15	86	120
09	11	18	M10	4.0	15	95	0.5	256	145	14	40	17	78	110	4 x M6	15	101	130

see dimensions diagram 28.M01-3-0031

All dimensions in mm keyway according to DIN 6885/1 standard voltage 24/105/180/205 V DC according to VDE 0580, ISO-class „B“, 100% on time,  
<sup>1)</sup> rated torque after running in process \* hub bore > ø 45 \*\*keyway according to DIN 6885/3, Attention: under the fixing screws are sealing washer (DIN7603) have to be used



**Option**

- Cold Climate Version CCV (-40 ... +60 °C)
- ISO class F + H

**Accessories COMBISTOP T**

- Flange
- Hand release
- Shaft sealing ring

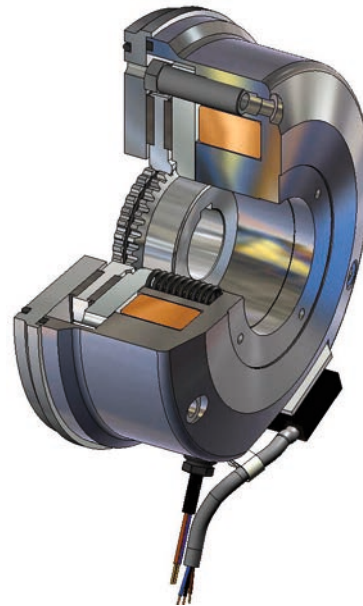

**ORDERING EXAMPLE: COMBISTOP T**

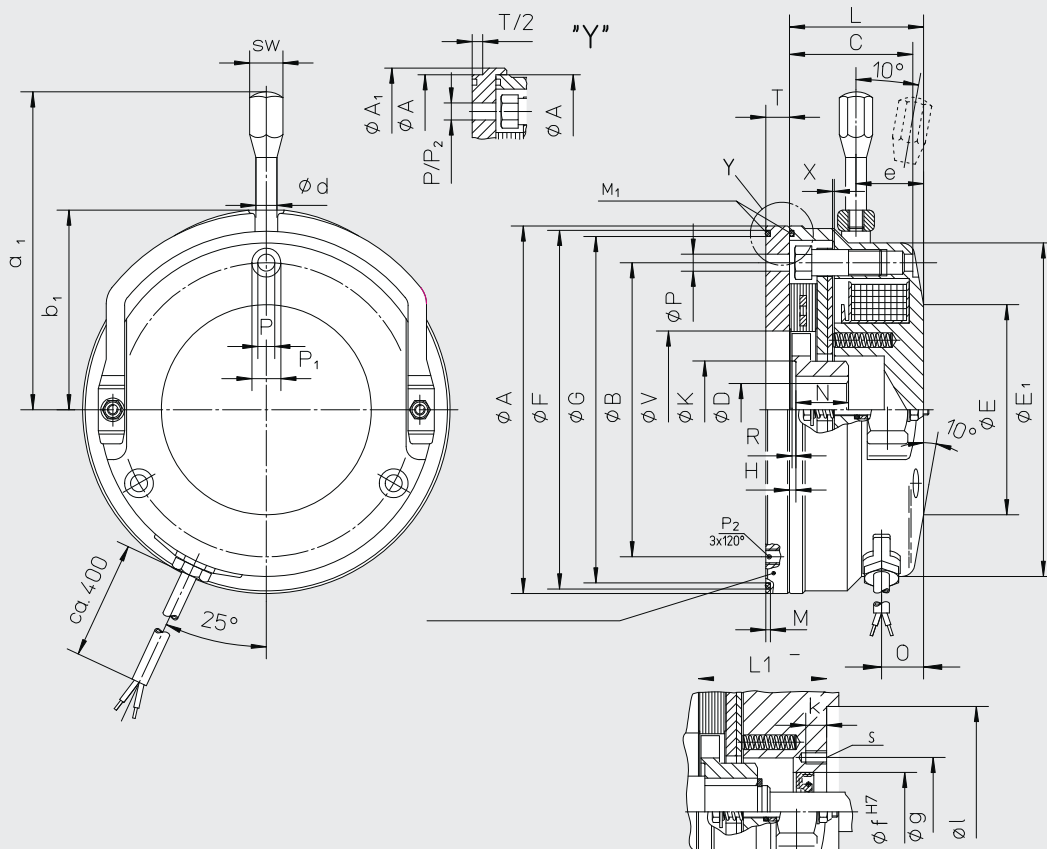
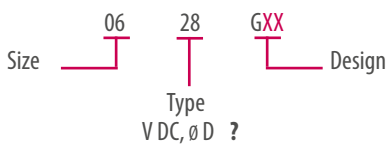

# COMBISTOP D AND L

**COMBISTOP D** stands for double safety and covers a series of double brakes, which is prepared for tasks with redundant brake circuits.

The mechanical construction with two completely independent fail-safe spring-applied brakes meets the requirements according to DIN 56950 (BGV C1).

The brakes are supplied ex factory, ready for attachment with preadjusted air gaps.

Extensive constructional measures reduce the switching and running noises to a minimum.

**Range of application:** e. g. theatre equipment, passenger and freight elevators

**Option:** ISO class F

SIZE	$T_{2N}^{1)}$ (Nm stat)	$P_{20}$ (W)	A	B	C	1 & 2 D (max)	E	F	H	$L_1$	$L_2$	M	$N_1$	$N_2$	$R_1$	T	X	a	b	$e_1$
02	2x5	2x25	85	72	22	15**	22	36	91.2	9.5	1.5	18	27.5	13	8	500	0.2	105.5	53.5	45.5
03	2x10	2x30	102	90	32	20	31	48	106	12.5	2.5	20	34	17	10	500	0.2	114	62	54
04	2x20	2x30	127	112	38	25	37	60	121	12.5	2.5	20	39	23	10	500	0.2	128	76	65
05	2x36	2x48	147	132	42	30	42	70	135	14	3	25	41	21	11	500	0.2	168	86	72
06	2x70	2x62	164	145	47	35**	42	70	157	16	3	30	45	20	13	500	0.3	176	96	81
07	2x100	2x65	190	170	62	45	57	75	180	18.5	3	30	59	37	15	750	0.3	225	115	94
08	2x150	2x75	218	196	78	60	57/76*	100	193	19.5	5	35	55	33	14.5	750	0.3	235	125	97
09	2x250	2x80	254	230	97	60	76	100	224	22	5.5	40	65	45	16.5	750	0.3	256	146	107
10	2x500	2x130	306	278	120	75	92	120	241	27	10	50	63	36	17	750	0.4	335	175	121
11	2x1000	2x180	on request																	

All dimensions in mm keyway according to DIN 6885/1 standard voltage 24 / 105 / 180 / 205 V DC according to VDE 0580, ISO-class „B“, 100% on time,  
1) rated torque after running in process \* hub bore > ø 45 \*\* keyway according to DIN 6885/3

**COMBISTOP L** as special development for the elevator industry the dual-circuit spring-applied fail-safe brake fulfills the valid requirements of EN 81 respectively TRA 227.

The brake series, tested by the technical inspection authority, contains two mechanical braking circuits and offers compact dimensions and easy mounting

**Range of application:** e. g. theatre equipment, passenger and freight elevators

**Option:** ISO class F \* H

Accessories **COMBISTOP L**

- Friction disc
- Flange
- Micro switch

SIZE	$2 \times T_{2N}^{1)}$ (Nm stat.)	$P_{20}$ (W)	A	B	C	$D^{H7}$	E	F	G	H		L		N	O	$X_n$
										D8230	D8630	D8230	D8630			
05	25	60	154	146	132	30	42	65	147	3	3	53.8	54.3	25	19.5	0.3
07	50	65	203	188	170	40	57	65	190	3	3	74.3	74.3	30	20	0.4
09	125	75	268	230	230	60	76	101	254	5	5	98.7	98.7	40	20	0.5

SIZE	a	b	d	e		l	m	$P_1^*$	$P_2^*$	$P_3^*$	$2 \times X_v$ D8630	SW	$\alpha^\circ$	$\delta^\circ$
				D8230	D8630			ISO 4762	ISO 4762	ISO 4762				
05	169	89	10	34.8	35.3	2.5	1.2	M6x65	M6x10	M5x40	0.15	14	10	28
07	225	115	14	33.5	33.5	2.5	1.3	M8x80	M8x12	M6x50	0.20	17	10	25
09	255	145	14	65.7	65.7	3.0	1.4	M10x100	M10x16	M8x75	0.25	17	10	25

All dimensions in mm keyway according to DIN 6885/1 standard voltage 24 / 105 / 180 / 205 V DC according to VDE 0580 ISO-class „B“ 100% on time,  
1) rated torque after running in process \* hub bore > ø 45 \*\* keyway according to DIN 6885/3 see dimension diagram D8.M01-4-0707

Accessories **COMBISTOP D**

- Friction disc
- Micro switch
- Dust protection ring
- Flange
- Friction disc with collar (up to size 06)

**ORDERING EXAMPLE: COMBISTOP D**

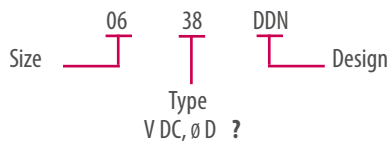

$e_2$	$d_1$	$d_2$	m	FASTENING SCREWS			
				Z	Z <sub>1</sub>	Z <sub>2</sub>	Z <sub>3</sub>
22.5	34.6	39	0.8	M4	3x8.8	3x8.8	3x8.8
27	37.7	47.5	1	M5	3x8.8	3x8.8	3x8.8
31	47.8	54.4	1.4	M6	3x8.8	3x8.8	3x8.8
33	53.4	55.9	1.5	M6	3x10.9	3x8.8	3x8.8
36	60.3	64.5	1.8	M8	3x10.9	3x8.8	3x8.8
45	68.8	77.6	2	M8	6x8.8	3x8.8	3x8.8
50	80.8	82.7	2	M8	6x10.9	3x10.9	3x10.9
56	89.4	95.4	2.3	M10	6x8.8	3x10.9	3x10.9
61	99.5	105	2.7	M10	6x10.9	6x8.8	3x8.8

see dimension diagram 38.003-3-0714

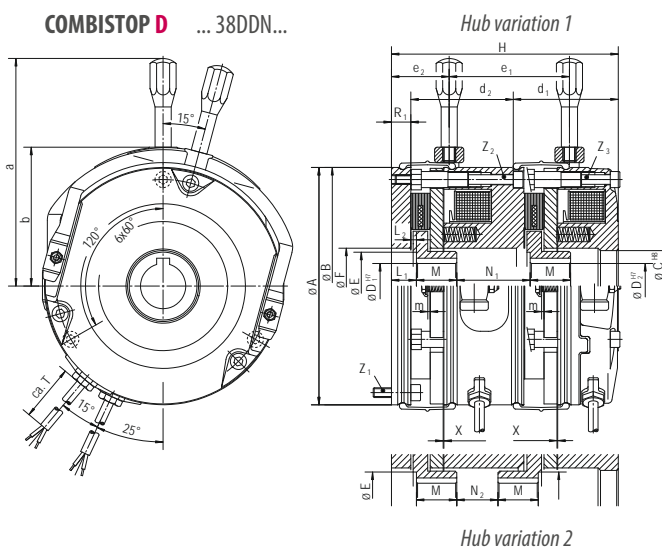

- COMBISTOP L .. D8230 ...** with hand release
- COMBISTOP L .. D8630 ...** with hand release, with backlash-free-hub lining system

**ORDERING EXAMPLE: COMBISTOP L**

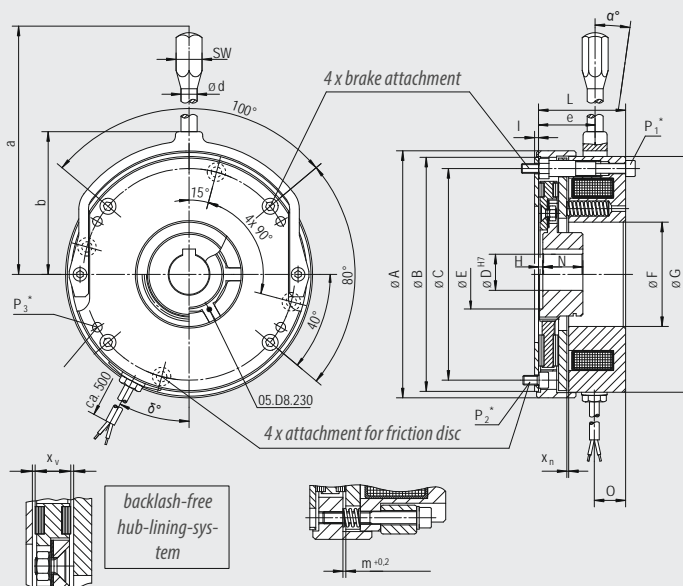

## COMBISTOP ACCESSORIES

To adapt the spring-applied brakes to the various requirements of different applications an extensive program with a wide range of accessories is available.

Please contact us to discuss your requirements. To ensure correct selection we have on hand an experienced team of application engineers to assist you in all aspects of selection, enabling you to get the optimum solution.

### ACCESSORIES - DUST PROTECTION RING (IP44) .. 08550-0009

	ARTICLE NUMBER XX08550-0009									
SIZE	02	03	04	05	06	07	08	09	10	11
B <sub>1</sub>	22,5	25	33	33,5	38,5	45,5	49	54,5	63	auf Anfrage!
W <sub>5</sub>	86	103	129	149	167	195	222	259	310	

All dimensions in mm

To protect the friction surfaces against dust or dripping water different sizes of dust protection rings are available. When fitting the COMBISTOP with a dust protection ring the friction disc **xx08515-xxxx** must be used on the motor side. This friction disc will be supplied nitrated and is especially designed to hold the dust protection ring.

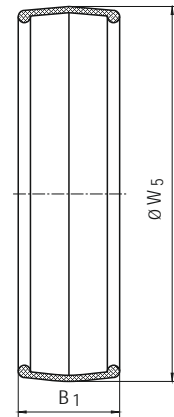

### ACCESSORIES - MICRO SWITCH

The use of COMBISTOP can be fitted with a micro switch for monitoring the functions and the wear.

The use of COMBISTOP with micro switch is particularly sensible for braking motors on hoisting gears that are operated with frequency inverters.

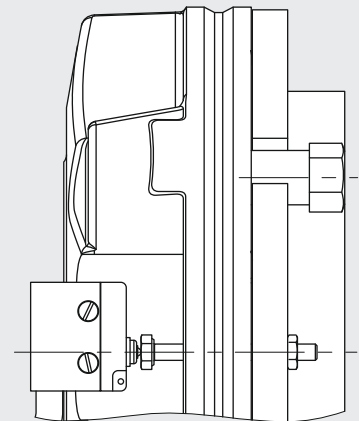



Friction discs and flanges provide suitable counter-rotation surfaces for the spring applied brakes and are available in hardened and rustproof design.

### ACCESSORIES - FRICTION DISC ... 08451 ...

SIZE	ARTICLE NUMBER XX08451-XXXX									
	02	03	04	05	06	07	08	09	10	11
B	72	90	112	132	145	170	196	230	278	
P	4,5	5,5	6,5	6,5	9	9	9	11	11	
T1	1,5	2	2	2	2,5	2,5	2,5	3	4	
P3	7,5	8,5	10,5	10,5	14,5	14,5	14,5	17	17	
V2	27	35,5	42,5	47	51	85	100	105	198	
W2	82	98	123	146	157	188	214	250	302	
Weight [kg]	0,05	0,10	0,15	0,22	0,30	0,40	0,64	0,93	1,50	

All dimensions in mm

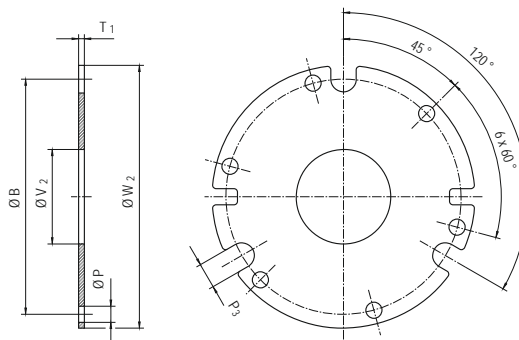

### ACCESSORIES - FRICTION DISC WITH COLLAR ... 08515 ...

SIZE	ARTICLE NUMBER XX08515-XXXX									
	02	03	04	05	06	07	08	09	10	11
B	72	90	112	132	145					
P	4,5	5,5	6,5	6,5	9					
T <sub>1</sub>	1,5	2	2	2	2,5					
V <sub>1</sub>	27	35,5	42,5	47	51					
W <sub>1</sub>	88,5	106	132	153	171					
Weight [kg]	0,05	0,10	0,15	0,25	0,35					

All dimensions in mm

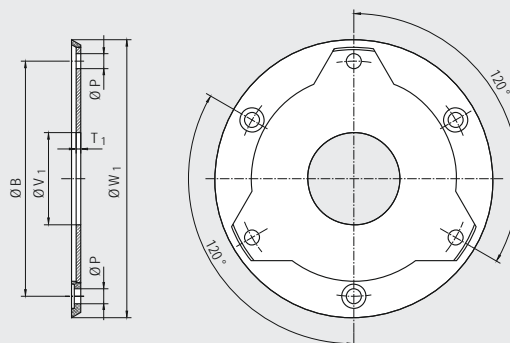

### ACCESSORIES - FLANGE WITH COLLAR FOR DUST PROTECTION RING ... 38510 ...

SIZE	ARTICLE NUMBER XX38510-0009										
	00	02	03	04	05	06	07	08	09	10	11
B	52	72	90	112	132	145	170	196	230	278	325
P4		3x4,3	3x5,3	3x6,4	3x6,4	3x9	3x9	3x9	3x11	6x11	6x13
S1		3xM4	3xM5	3xM6	3xM6	3xM8	3xM8	3xM8	3xM10	6xM10	6xM12
T4	5	6	7	9	9	11	11	11	11	12,5	20
V4	26	20	30	40	45	55	65	75	90	120	160
W3	60	83	100	125	145	163	190	217	254	306	363
Weight [kg]	0,08	0,20	0,35	0,75	1	1,50	2,10	2,70	3,70	5,90	12,7

All dimensions in mm

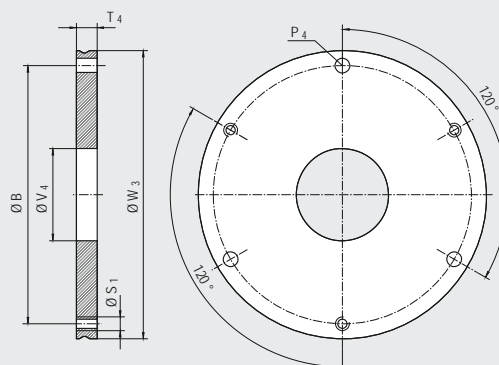

# COMBISTOP TECHNICAL DATA

SIZE	Operating-stop [rpm]	max. speed		J Type M. T [10 <sup>-3</sup> kgm <sup>2</sup> ]	G <sub>min</sub> [mm]	X <sub>N</sub> [mm]
		Type M. T emergency stop [rpm]	Type N. H. D emergency stop [rpm]			
00	3,000	6,000	-	0.001	-	-
02	3,000	6,000	6,000	0.025	5.5	0.4
03	3,000	6,000	6,000	0.072	6.5	0.5
04	3,000	6,000	6,000	0.136	8	0.6
05	3,000	5,000	5,000	0.35	10	0.6
06	3,000	5,000	5,000	0.56	10	1
07	3,000	4500	4500	1.57	10	1
08	3,000	3500	3500	5.92	11	1.2
09	1,500	3,000	3,000	7.38	12	1.2
10	1,500	3,000	3,000	20.54	14	1.5
11	1,500	2,000	2,000	180.7	28	1.5

*g<sub>min</sub>* min. permissible lining thickness [mm] 1) for brake type D use for calculation 2 x [J]

## PERMISSIBLE FRICTION $W_{Rmax}$ [J] DEPENDENT THE SWITCHING FREQUENCY

Valid only for the stated revolutions per minute

type **M, T, N, H, D** size 00 ... 07 - 3000 rpm

type **T, N, H, D** size 08 ... 11 - 1500 rpm

The values for  $W_{Rmax}$  are valid for standard brakes and a second friction surface of casting. Depending on application these values may be exceeded or remained under. Rustfree friction discs, or speeds higher than specified in the diagram, reduce the permissible friction work considerably. If the rated torque of the brake is reduced by turning the adjustment ring (optional) the permissible friction work increases.

Friction switching frequency Type M, T

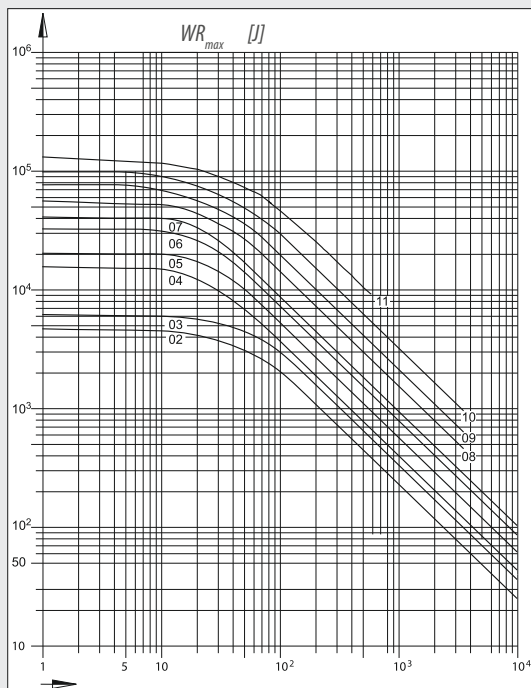

switching frequency per hour  
Red line for brake without friction disc

Friction switching frequency Type N, H, D

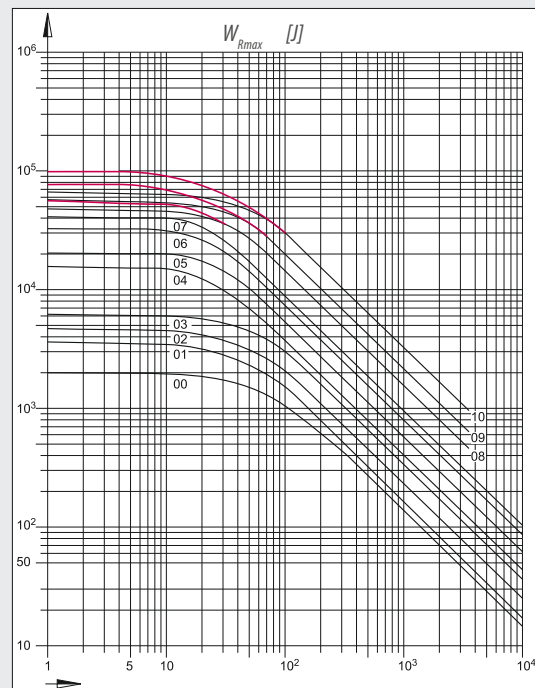

switching frequency per hour

## SWITCHING CYCLES AND SWITCHING TIMES

SIZE	SWITCHING CYCLES						AC-SWITCHING				DC-SWITCHING			
	SC <sub>1</sub>		SC <sub>2</sub>		t <sub>2</sub>		t <sub>11~</sub>		t <sub>1~</sub>		t <sub>11=</sub>		t <sub>1=</sub>	
	M, T	N, H, D	M, T	N, H, D	M, T	N, H, D	M, T	N, H, D	M, T	N, H, D	M, T	N, H, D	M, T	N, H, D
00	70		140		35		60		100		12		25	
02	60	60	120	120	40	40	40	70	90	100	10	10	20	20
03	40	60	75	75	60	55	80	100	140	150	15	15	30	30
04	40	60	75	75	100	90	140	180	200	200	20	25	50	50
05	25	25	50	50	120	110	180	220	240	240	25	25	55	55
06	5	5	10	10	240	240	200	260	330	330	25	25	90	90
07	5	5	10	10	240	220	400	400	650	650	50	40	150	120
08	5	5	10	10	300	320	700	700	900	900	60	50	180	180
09	2	2	5	5	350	350	900	900	1,200	1,200	60	60	220	220
10	1	2	3	3	350	400	1,400	1,400	1,800	2,000	60	100	250	300
11		1		2		750		3,100		3,500		450		1000

SC<sub>1</sub> applicable for rectifiers:

0291010-CE07

0291020-CE07

0291010-CEMV

SC<sub>2</sub> applicable for rectifiers:

0491010-CE07

0491020-CE07

0591010-CE09

0691010-CE09

COMBISTOP Typs: M, T, N, H, D (see page 4)

### SC maximum permissible switching cycle

at DC-side switching, 100% on time and max. operating temperature of 80 °C.

[rpm]

### t<sub>1</sub> engaging time

time from disconnecting the current to attaining the rated torque.

[ms]

### t<sub>11</sub> engaging delay time

time from disconnecting the current to the rise of the torque.

[ms]

### t<sub>2</sub> release time

time from connecting the current to the beginning of torque decrease.

[ms]

The designation of the switching times corresponds to DIN VDE 580

## SWITCHING CYCLES COMBISTOP WITH POWERBOX

SIZE	t <sub>2</sub>	max. air gap	switching cycles
	[ms]	[mm]	[rpm]
02	20	1.0	55
03	35	1.8	40
04	50	2.1	40
05	60	3.0	25
06	120	3.0	5
07	120	3.5	5
08	150	3.0	5
09	170	3.5	2
10*	180	4.5	1

### POWERSUPPLY

COMBISTOP requires DC voltage for operation. For the power supply different half-wave or full-wave rectifiers of the series COMBITRON 98 are available for DC or AC-side switching, which, depending on the type, are suitable for connection voltages up to 720 V AC rated voltage.

The switching characteristics and functions of the COMBISTOP can be optimized through the rapid switch rectifier COMBITRON 98..

\* Continuous operation only permissible 45 °C!

230 V AC input voltage and 105 V DC coil Switching times apply to rated air gap X  
Switching cycles apply to DC side switching

# COMBIPERM PROGRAM SCHEDULE

COMBIPERM are electromagnetically released permanent magnet brakes and clutches for dry operation whose flux is generated by permanent magnets. This effect permits the connection of shafts in voltage free condition or the safe deceleration of masses.

You find possible shaft diameters in the "Bore Table" on page 51.  
On request we adapt COMBIPERM to your constructional and electrical requirements.

## PROGRAM SCHEDULE

### COMBIPERM quiescent-current operated brakes and clutches

Holding brake with Emergency-Stop-function	0.4 ... 145 Nm	page 17	COMBIPERM P1
Clutch quiescent-current operated	6 ... 120 Nm	page 19	COMBIPERM PC

## TECHNICAL DATA

Switching times	page 20
Moments of inertia, friction, -rating	page 21
Dimensioning / Calculation	page 50
Bore table COMBINORM / COMBIPERM	page 51

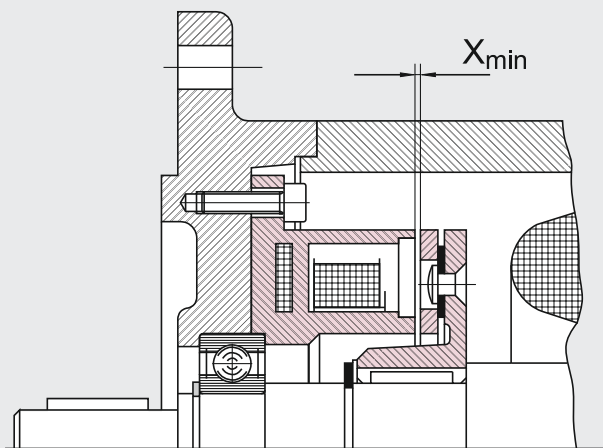

COMBIPERM P1

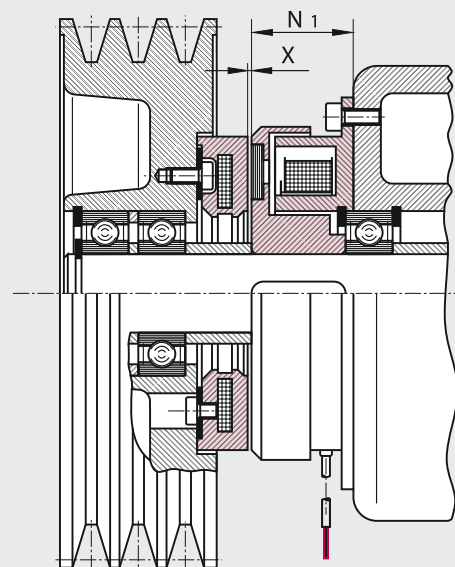

COMBIPERM PC



**COMBIPERM P1 FIRST CHOICE FOR YOUR SERVOMOTOR**

are powerful permanent magnet brakes with frictionally engaged, backlash-free effect. Rare earth magnets create a force field, which is cancelled by the counter-pole magnet coil (opened) in current-supplied condition and in combination with the membrane spring on the armature it ensures a residual torque-free separation independent of the installation position.

COMBIPERM P1 are designed for rated operating voltage 24 V DC according to ISO class F (max. 155 °C) and ensure a safe operation within a wide range of temperatures. On request versions in other operating voltages are available.

certified to

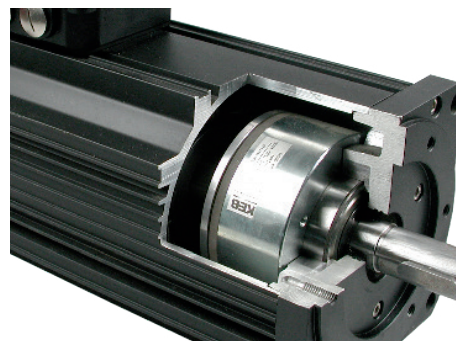

**Range of application:** e.g. machine building, medical technology, industrial robots, servo-drives

Please bear in mind

- that magnetic materials within the direct surroundings can weaken the torque, reduce maximal air gaps and lead to a shifting of the release range.
- that the rated torques are achieved after a required running-in process (please see instruction manual).
- that the torques become less at higher speeds

**ORDERING EXAMPLE: COMBIPERM P1**

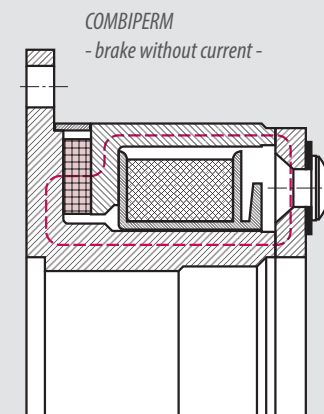
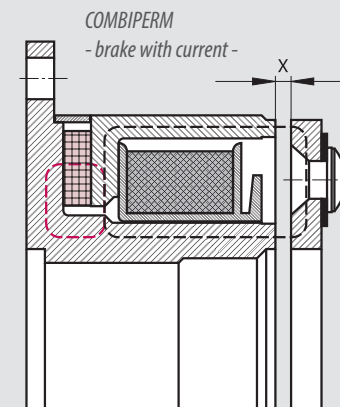
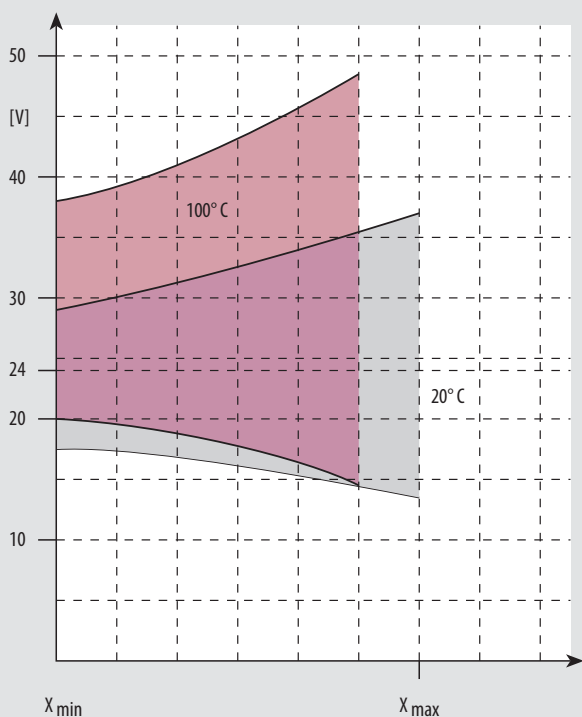
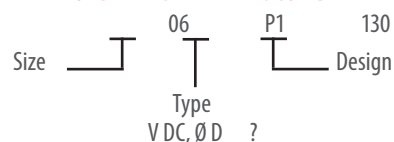

# COMBIPERM P1

SIZE	T <sub>2N</sub> <sup>1)</sup> [Nm]	P <sub>20</sub> [W]	A <sub>h8</sub>	A <sub>1</sub>	A <sub>2h8</sub>	A <sub>3</sub>	B	B <sub>1</sub>	C <sup>H8</sup>	C <sub>1</sub>	C <sub>2</sub>	D	E	ØF	G	H	J	K
01	0.4	8	39	28	28	32	33.5	22	11	13.5	-	28	19.5	3.4	2x2.1	5.3	4.5	-
02	1	10	45	32.2	32	34	38	23	12.5	16	-	32	23	3.4	3x2.6	6	5	-
03	2	11	54	41	40	42	47	28.5	19	22	-	40	30	3.4	3x3.1	6	5.5	-
05	4.5	12	65	51.5	50	53	58	40	26	24	24	50	38	3.4	3x3.1	6.5	5.5	2
06	9	18	80	64	63	66	72	49	35	32	32	63	50	4.5	3x4.1	10	8	2
07	18	24	100	80.8	80	83	90	63	42	38	38	80	60	5.5	3x4.1	11	8	2
08	36	26	125	101	100	103	112	78	52	48	48.5	100	76	6.5	3x5.1	11.5	10	2.5
09	72	40	150	126	125	128	137	106	62	57	58	125	95	6.5	3x6.1	15	11.5	3.5
10	145	50	190	161	160	163	175	135	80	71	75	160	120	9	3x8.1	21	14.5	3.5

SIZE	K <sub>1</sub>	L	L <sub>1</sub>	L <sub>2</sub>	M	N	P	R	R <sub>1</sub>	R <sub>2</sub>	S	d <sub>20</sub> <sup>H7</sup>	d <sub>30</sub> <sup>H7</sup>	d <sub>30</sub> <sup>H7</sup>	X <sub>min</sub>	X <sub>max</sub> <sup>20°</sup>	Z	weight kg
01	3	19.5	2	10.5	2xM3	3	1	2.25	4.25	2.7	7	6	6	8	0.15	0.3	1xM3	0.1
02	2	21.5	2	10.5	3xM3	3	1.3	2.1	4.1	4	10	8	8	10	0.15	0.3	1xM3	0.1
03	2	22.5	2	12	3xM3	3	1.5	2.6	5.2	5	12	10	12	15	0.15	0.4	1xM4	0.2
05	2	28.5	2	14	3xM3	3	1.5	3	6	5	12	15	15	19	0.2	0.5	1xM5	0.35
06	3	26.8	3	15	3xM4	4	2	3.9	7.4	6	15	18	18	25	0.3	0.65	1xM6	0.55
07	3	29.9	3	16.5	3xM4	5	2	4.5	8.5	8	20	25	25	30	0.3	0.8	1xM6	0.85
08	4	33.9	4	19.5	3xM5	6.2	2.5	6.2	11.2	10	25	30	30	38	0.35	0.9	1xM8	1.6
09	5	37.8	5	23	3xM6	7	3	7.3	13.3	12	30	40	40	50	0.4	1.0	2xM10	2.9
10	6	42.6	6	24	3xM8	9.5	4	9.4	16.4	15	38	50	50	65	0.5	1.2	2xM10	5.4

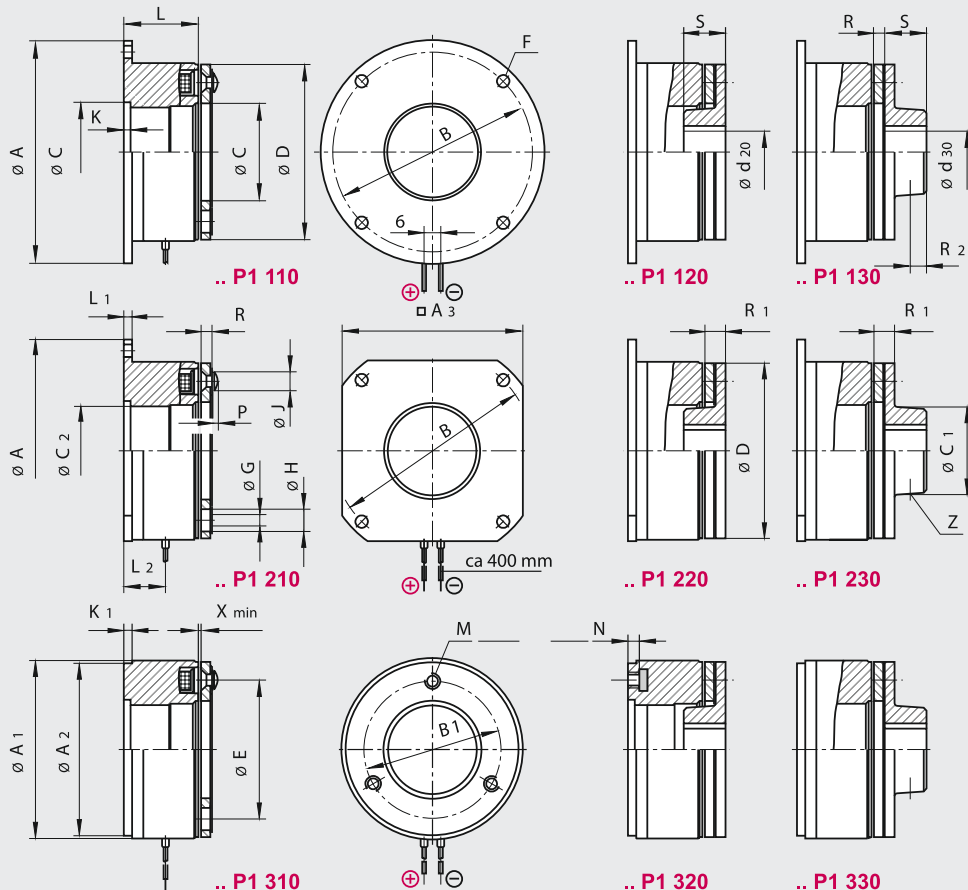

are permanent magnet clutches, which transmit in currentless condition frictionally engaged torque. The magnetic circle is optimized by the arrangement of the permanent magnets in the armature, thus permitting the transmission of high torques on small constructional spaces. The opening of the friction-type connection takes place by the antipole connection of the electromagnetic circuit, thereby neutralizing the force action of the permanent magnets

**Range of application:** e.g. robot technique, medical equipment

SIZE	$T_{2N}^{1)}$	$P_{20}$	Data
	[Nm]	[W]	
06	6	18	upon request
07	12	24	
08	24	28	
09	50	35	
10	120	50	

1) rated torque after running in process

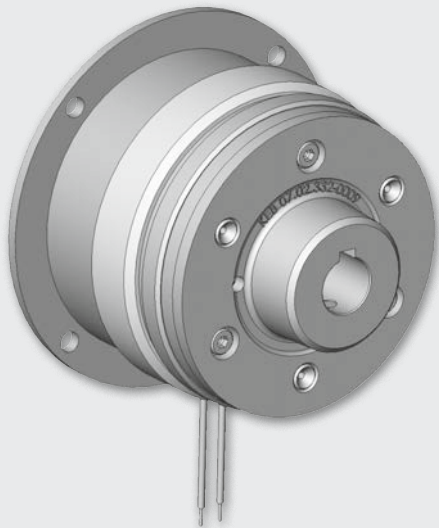

07PC230-xxxx

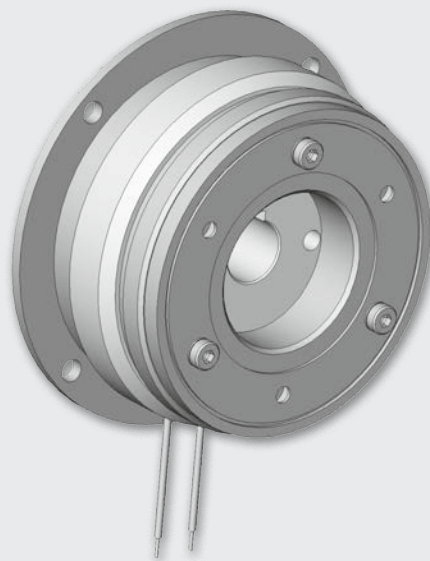

07PC110-xxxx

# COMBIPERM TECHNICAL DATA

Permissible friction  $W_{Rmax}$  [J] depending on the switching frequency type P1

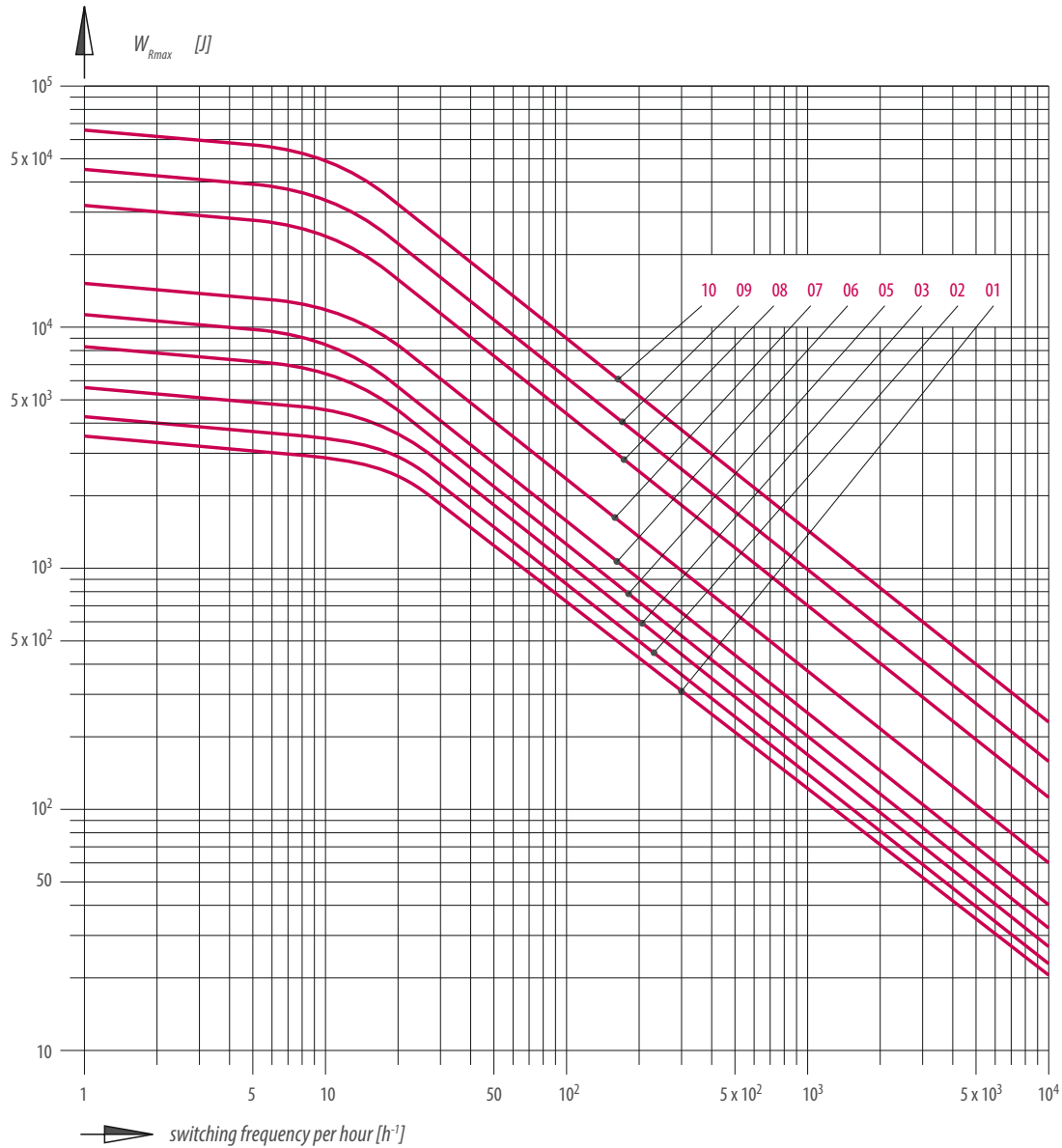

The values for  $W_{Rmax}$  apply to a speed 3000 rpm. Dependent on the actual application  $W_{Rmax}$  may exceed or fall below these values..

## POWER SUPPLY

COMBIPERM P1 needs a smoothed DC voltage. To ensure a safe operation in case of large temperature variations, the coil should be supplied with constant current.

Please pay attention to the polarity of the connection leads.  
(positive = red, negative = black).



## COMBIPERM P1

SIZE			01	02	03	05	06	07	08	09	10
$T_{2N}$	20 °C	[Nm]	0.4	1	2	4.5	9	18	36	72	145
$T_{stat.}$	100 °C		0.35	0.8	1.8	4	8	15	32	62	130
$T_{dyn.}$	20 °C	[Nm]	0.3	0.8	1.7	3.8	7.5	15	28	55	110
		[kgm <sup>2</sup> ]	0.001	0.001	0.001	0.001	0.002	0.004	0.012	0.036	0.1
		[rpm]	3,000	3,000	3,000	3,000	2,000	2,000	2,000	2,000	2,000
$P_{20}$		[W]	8	10	11	12	18	24	26	40	50
<b>J</b>											
<b>Armature</b>	P1.110	[10 <sup>-4</sup> kgm <sup>2</sup> ]	0.01	0.014	0.045	0.122	0.37	1.15	4	11.5	39
	P1.120/130		0.013	0.021	0.068	0.18	0.54	1.66	5.56	16	53
$W_{R0,1}$		[kJ]	200	300	410	580	890	1,290	2,900	6,200	13,000
		[kgm <sup>2</sup> ]	0.001	0.001	0.001	0.001	0.0015	0.004	0.0120	0.036	0.1
		[rpm]	3,000	3,000	3,000	3,000	2,000	2,000	2,000	2,000	2,000
$X_{max}$	20 °C	[mm]	0.3	0.3	0.4	0.5	0.65	0.8	0.9	1	1.2
$X_{min}$			0.15	0.15	0.15	0.2	0.3	0.3	0.35	0.4	0.5
$n_{max}$		[rpm]	10,000	10,000	10,000	10,000	10,000	10,000	10,000	8,000	8,000
<b>Switching times</b>	$t_2$	[ms]	10	12	25	35	40	50	90	140	190
	$t_{11} =$		2	2	2	2	2	3	3	7	12
	$t_1 =$		6	6	6	7	7	10	22	25	65

## LEGEND

$T_{2N}$	rated torque after running in process (slip speed 20 rpm)	[Nm]	$t_1$	<b>Engaging time:</b> Time from disconnecting the current until the rated torque is attained	[ms]
$T_{stat.}$ 100 °C	rated torque at 100 °C (slip speed 20 rpm)	[Nm]	$t_{11}$	<b>Engaging delay time:</b> Time from disconnecting the current until the torque rises	[ms]
$T_{dyn.}$ 20 °C	switching torque at specified conditions	[Nm]	$t_2$	<b>Release time:</b> Time from connecting the current until the torque decreases	[ms]
$P_{20}$	power at 20 °C	[W]			
<b>J</b>	moment of inertia	[kgm <sup>2</sup> ]			
$n_{max}$	max. speed	[rpm]			
$X_{min}$	nominal air gap	[mm]			
$X_{max}$	max. air gap at which the armature attracts	[mm]			
$W_{R0,1}$	friction work up to 0.1 mm abrasion	[kJ]			

The stated switching times are achieved with adjusted nominal air-gap ( $x_{min}$ ). These are averages whose dispersion depends on the power supply and coil temperature.

# COMBINORM PROGRAM SCHEDULE

COMBINORM - operating-current operated brakes and clutches use the flux of an electromagnet, concentrated on two pole surfaces, for the connecting, separating or holding of shafts and the connected loads.

COMBINORM covers a complete program with brakes, clutches and combinations as installation and attachment components for the applications in machines, plants and equipment in the application range of 0.5 to 500 Nm.

On request we adapt the KEB COMBINORM to your constructional and electrical requirements. Please bear in mind that the rated torques are achieved after a required running-in process.

## PROGRAM SCHEDULE

### COMBINORM OPERATING-CURRENT OPERATED BRAKES AND CLUTCHES

Operating current brake	0.5 ... 500 Nm	page 24	<b>COMBINORM B</b>
Operating current clutch-brake-combination	7 ... 500 Nm	page 26	<b>COMBINORM K</b>
Operating current clutch	0.5 ... 500 Nm	page 27	<b>COMBINORM C</b>
Operating current toothed clutch	21 ... 390 Nm	page 32	<b>COMBINORM T</b>

### FLANGE MOUNTED BRAKE COMBINORM B ... 02120 ...

- ① brake magnet
- ② armature
- ⑤ hub
- ⑥ spring

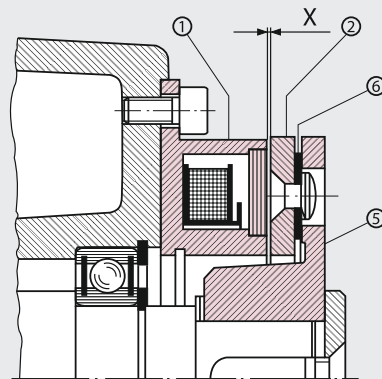

### FLANGE MOUNTED CLUTCH COMBINORM C and T .. 03110 ...

- ② armature
- ③ clutch magnet
- ④ rotor
- ⑥ spring

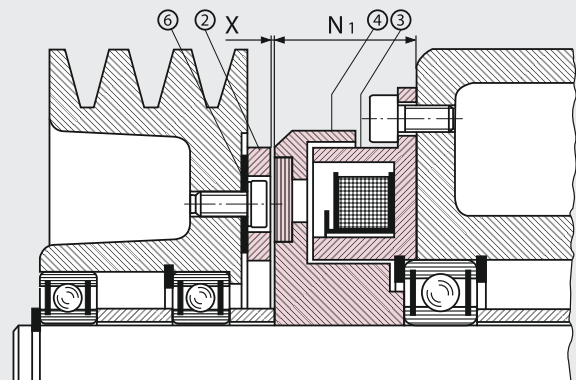

**TECHNICAL DATA**

Switching times	page 34
Moments of inertia, friction, rating	page 35
Dimensioning / Calculations	page 50
Bore table COMBINORM / COMBIPERM	page 51

**ORDERING EXAMPLE: COMBINORM C**

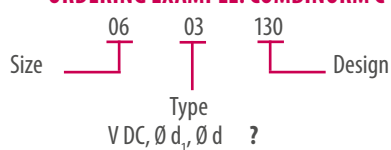

**SHAFT MOUNTED CLUTCHES**  
**COMBINORM C and T ... 03810 ...**

- ② armature
- ③ clutch magnet
- ④ rotor
- ⑥ spring

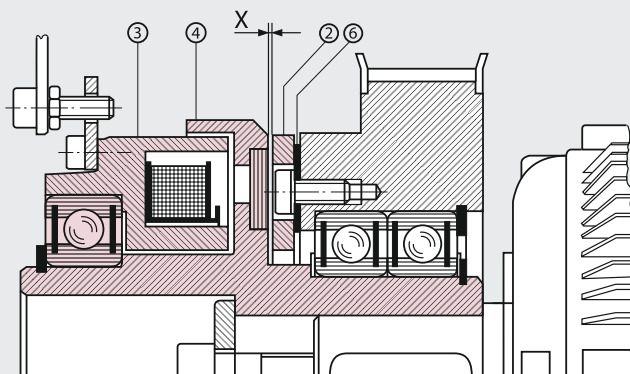

**CLUTCH-BRAKE-COMBINATION**  
**COMBINORM K ... 04170 ...**

- ① brake magnet
- ② armature
- ③ clutch magnet
- ④ rotor
- ⑤ hub
- ⑥ spring

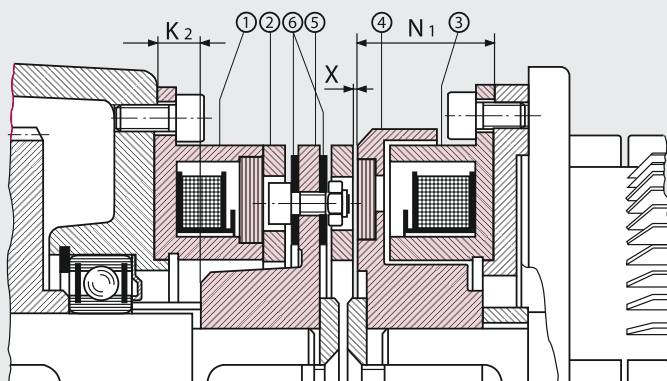

# COMBINORM B

SIZE	$\frac{1}{2N}$ [Nm]	$P_{20}$ [W]	$A_{h8}$	B	$C^{H8}$	$C_1$	$C_2$	$d/d_4$ max	$d_5$	D	E	F	G	H	J	K	$K_1$	M
01	0.5	6	39	33.5	11	13.5	-	6		28	19.5	3.4	2 x 2.1	5.3	4.5	-	-	9.3
02	0.75	6	45	38	13	16	13.6	8		32	23	3.4	3 x 2.6	6	5	3	1.1	12.1
03	1.5	8	54	47	19	22	20	10		40	30	3.4	3 x 3.1	6	5.5	3	1.1	14.7
05	3	10	65	58	26	24	27	15		50	38	3.4	3 x 3.1	6.5	5.5	3.2	1.3	15
06	7	12	80	72	35	32	36	20	18	63	50	4.5	3 x 4.1	10	8	3.5	1.6	18.8
07	15	16	100	90	42	38	43.5	22	21	80	60	5.5	3 x 4.1	11	8	4.25	1.85	24.3
08	30	21	125	112	52	48	53.8	30	28	100	76	6.6	3 x 5.1	11.5	10	5	2.15	31
09	65	28	150	137	62	58	63.8	35	35	125	95	6.6	3 x 6.1	15	11.5	5.5	2.15	36.9
10	130	38	190	175	80	73	82.1	45	44	160	120	9	3 x 8.1	21	14.5	6	2.65	46.9
11	250	50	230	215	100	92	102.1	60		200	158	9	3 x 10.1	19	17.5	7	3.15	59.2
12	500	65	290	270	125	112	127.4	70		250	210	11	4 x 12.1	28	20.5	8	4.15	68

13 Dimensions and technical data see drawing 02.004-4-01001

available shaft diameters page 51

All dimensions in mm  $\emptyset$  „d“ keyway according to DIN 6885/1-P9 (design ..02110/120/130)  $\emptyset$  „d4“ keyway according to DIN 6885/1-H8 (design ..02230)

COMBINORM B are the most economical solution for the deceleration and holding of loads for the flange- and shaft-mounted installation in machines and plants.

The magnets with a rated voltage of 24 V DC are designed according to ISO class B and are available in various special voltages on request.

Shaft mounted brakes  
COMBINORM B ... 02320 ...

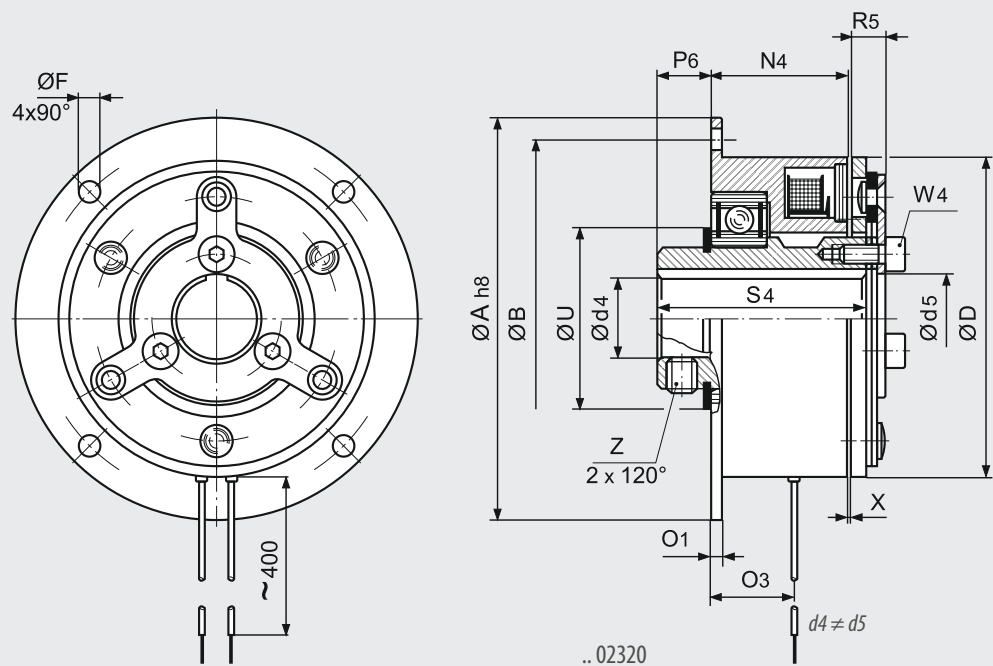

N	N <sub>4</sub>	O	O <sub>1</sub>	O <sub>3</sub>	P	P <sub>6</sub>	R	R <sub>1</sub>	R <sub>5</sub>	S	S <sub>4</sub>	U	V <sub>1</sub>	W <sub>4</sub>	X	Z	Z <sub>1</sub>	weight [kg]		
																		110	120/130	320
13.7		5	1.5		1		2.3	4.3		7			2.5		0.1		1 x M3	0.05	0.05	
17		7.5	2		1.3		2.1	4.1		10			4		0.15		1 x M3	0.1	0.1	
20		7	2		1.5		2.7	5.3		12			5		0.15		1 x M4	0.15	0.15	
22		7.5	2		1.5		3	6		12			5		0.2		1 x M5	0.2	0.25	
18	31.2	6	3	19	2	9.3	3.8	7.3	6.3	15	45	39	6	M4	0.2	M6	1 x M6	0.3	0.3	0.8
20	34.2	7	3	21.5	2	13.2	4.3	8.3	6.9	20	52.5	45	8	M5	0.2	M8	1 x M6	0.5	0.6	1.5
22	38	8	4	24	2.5	13.5	6	11	9.3	25	58.5	56	10	M6	0.2	M8	1 x M8	0.9	1.1	2.7
24	40	9	4	25	3	13.8	6.9	12.9	10.9	30	62	61	12	M8	0.3	M8	2 x M10	1.7	2	4.2
26	46.3	11	5	31.5	4	17.3	8.9	15.9	14.1	38	74	84	15	M10	0.3	M10	2 x M10	3.2	4	7.8
30		12	5		4.5		11.2	20.2		48			19		0.4		2 x M12	5.9	7	
35		15	6		5		13	24		55			22		0.4		2 x M12	11.2	13.5	

Standard voltage 24 V DC VDE 0580, ISO-class „B“ <sup>1)</sup> rated torque after running in process

**Range of application:** e.g. mail processing, winding equipment, door and gate systems, roller conveyor, strapping machines, balancing machines, sorting machines.

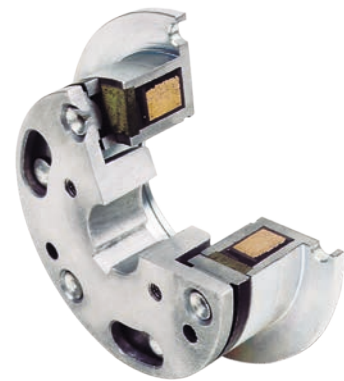

Flange mounted brake  
COMBINORM B ... 021X0 ...

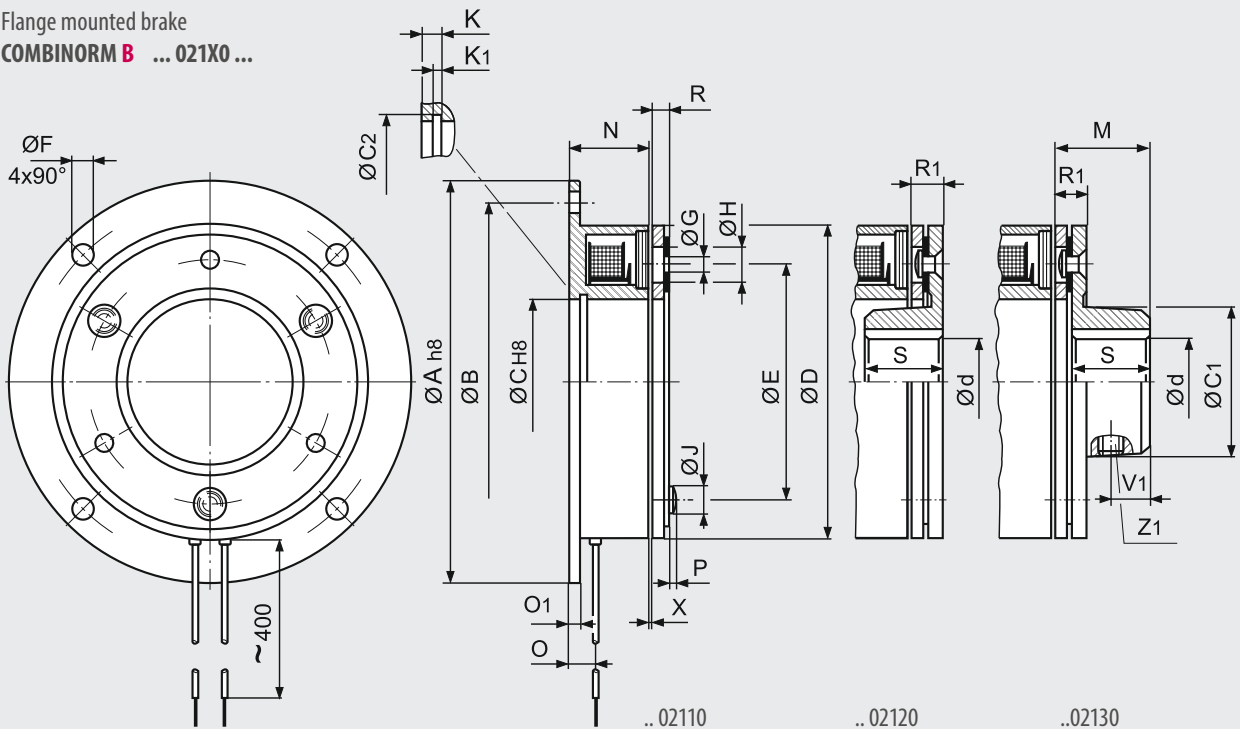

# COMBINORM K

SIZE	$T_{2N}^{1)}$	$P_{20}$		$A_{h8}$	B	$C^{H8}$	$C_2$	d	$d_1$	F	K	$K_1$	$K_2$	$L_5$	N	$N_1$	O	$O_1$	$R_2$	S	$S_6$	X	Weight [kg]
	[Nm]	[W]																					
		K	B				max.	max.															
06	7	15	12	80	72	35	36	20	20	4.5	3.5	1.6	11.2	55.1	18	24	6	3	12.9	15	20	0.2	0.85
07	15	20	16	100	90	42	43.5	22	25	5.5	4.25	1.85	9.3	61.3	20	26.5	7	3	14.6	20	22	0.2	1.5
08	30	28	21	125	112	52	53.8	30	30	6.6	5	2.15	8.9	71	22	30	8	4	18.8	25	24.5	0.2	2.7
09	65	35	28	150	137	62	63.8	35	35	6.6	5.5	2.15	7.9	79.6	24	33.5	9	4	21.8	30	27.5	0.3	4.8
10	130	50	38	190	175	80	82.1	45	50	9	6	2.65	5	90.8	26	37.5	11	5	27	38	31	0.3	9.5
11	250	68	50	230	215	100	102.1	60	65	9	7	3.15	3.4	108.2	30	44	12	5	33.8	48	37	0.4	17.9
12	500	85	65	290	270	125	127.4	70	80	11	8	4.15	5.1	125.6	35	51	15	6	39.2	55	43.5	0.4	31.5

available shaft diameters page 51

All dimensions in mm keyway according to DIN 6885/1-P9 Standard voltage 24 V DC VDE 0580, ISO-class „B“ <sup>1)</sup> rated torque after running in process

COMBINORM K covers a series of houseless construction units, designed for the connection and holding of auxiliary drives, allowing a backlash-free transmission with spring-controlled armature systems. The installation is done directly in the machine construction.

**Range of application:** e.g. paper processing, laundry folding equipment, feeder

Clutch-brake-combination  
COMBINORM K ... 04170 ...

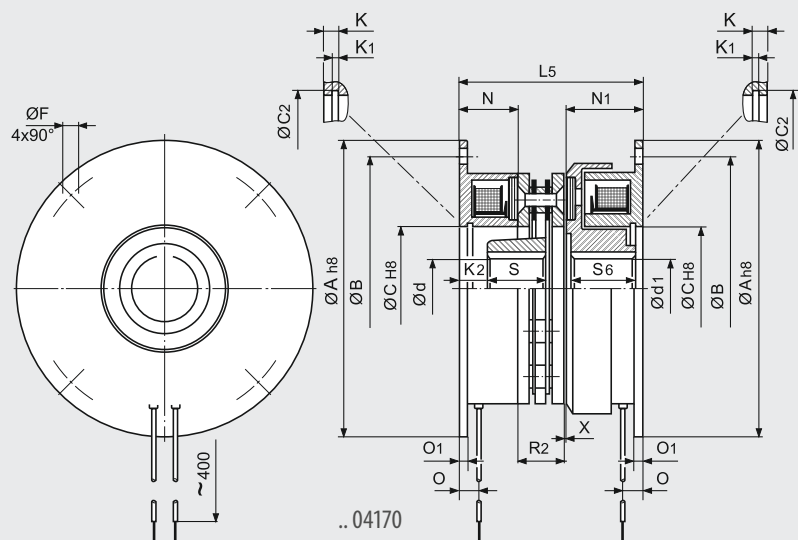



SIZE	T <sub>2N</sub> <sup>1)</sup> [Nm]	P <sub>20</sub> [W]	A <sub>h8</sub>	B	C <sup>H8</sup>	C <sub>1</sub>	C <sub>2</sub>	d max	d <sub>1</sub> max	D	E	F	G	H
01	0.5	6	39	33.5	11	13.5	-	6	6	28	19.5	3.4	2 x 2.1	5.3
02	0.75	6	45	38	13	16	13.6	8	8	32	23	3.4	3 x 2.6	6
03	1.5	8	54	47	19	22	20	10	10	40	30	3.4	3 x 3.1	6
05	3	10	65	58	26	24	27	15	15	50	38	3.4	3 x 3.1	6.5
06	7	15	80	72	35	32	36	18	20	63	50	4.5	3 x 4.1	10
07	15	20	100	90	42	38	43.5	22	25	80	60	5.5	3 x 4.1	11
08	30	28	125	112	52	48	53.8	30	30	100	76	6.6	3 x 5.1	11.5
09	65	35	150	137	62	58	63.8	35	35	125	95	6.6	3 x 6.1	15
10	130	50	190	175	80	73	82.1	45	50	160	120	9	3 x 8.1	21
11	250	68	230	215	100	92	102.1	60	65	200	158	9	3 x 10.1	19
12	500	85	290	270	125	112	127.4	70	80	250	210	11	4 x 12.1	28

SIZE	J	K	K <sub>1</sub>	M	N <sub>1</sub>	O	O <sub>1</sub>	P	R	R <sub>1</sub>	S	S <sub>1</sub>	T	V <sub>1</sub>	X	Z <sub>1</sub>	Weight [kg]	
																	110	130
01	4.5	-	-	9.3	18	5	1.5	1	2.3	4.3	7	16.5	31	2.5	0.1	1 x M 3	0.1	0.1
02	5	3	1.1	12.1	22.2	7.5	2	1.3	2.1	4.1	10	20.2	34	4	0.15	1 x M 3	0.1	0.1
03	5.5	3	1.1	14.7	25.4	7	2	1.5	2.7	5.3	12	23.4	43	5	0.15	1 x M 4	0.2	0.2
05	5.5	3.2	1.3	15	28.1	7.5	2	1.5	3	6	12	26.1	54	5	0.2	1 x M 5	0.35	0.4
06	8	3.5	1.6	18.8	24	6	3	2	3.8	7.3	15	22	67	6	0.2	1 x M 6	0.5	0.5
07	8	4.25	1.85	24.3	26.5	7	3	2	4.3	8.3	20	24	85	8	0.2	1 x M 6	0.9	1
08	10	5	2.15	31	30	8	4	2.5	6	11	25	27	106	10	0.2	1 x M 8	1.6	1.8
09	11.5	5.5	2.15	36.9	33.5	9	4	3	6.9	12.9	30	30	133	12	0.3	2 x M 10	2.8	3.1
10	14.5	6	2.65	46.9	37.5	11	5	4	8.9	15.9	38	34	169	15	0.3	2 x M 10	5.6	6.3
11	17.5	7	3.15	59.2	44	12	5	4.5	11.2	20.2	48	40	212.5	19	0.4	2 x M 12	9.7	11
12	20.5	8	4.15	68	51	15	6	5	13	24	55	47	266	22	0.4	2 x M 12	17.9	20.3

available shaft diameters page 51

All dimensions in mm keyway according to DIN 6885/1-P9 Standard voltage 24 V DC VDE 0580, ISO-class „B“ <sup>1)</sup> rated torque after running in process

COMBINORM C the switchable shaft connections are proven millions of times in the machine building and allow the controlled connection and disconnection of functional parts in an especially easy manner. Electromagnets according to ISO class B with rated voltage of 24 V DC create a flux, whose effect leads over the pole surfaces of the rotors and armatures. Available on request in various special voltages.

**Range of application:** e.g. paper processing, winding drives, door and gate systems, feed strapping machines, sorting machines

Flange mounted clutches  
COMBINORM C ... 031X0 ...

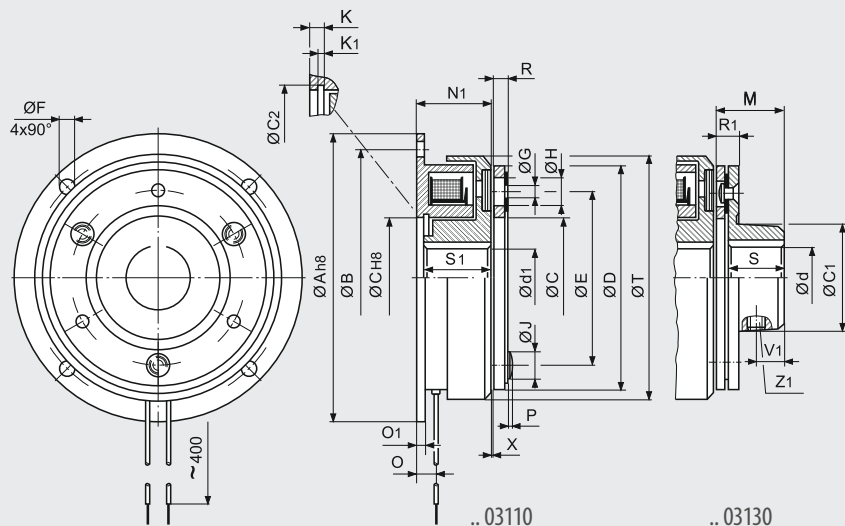

# COMBINORM C

TABLE (1)

SIZE	$T_{2N}^{1)}$ [Nm]	$P_{20}$ [W]	$B_1$	C	$C_1$	$C_4$	d max	$d_2$ max	$d_6$ max	D	E	$F_1$	G	H	J	$L_4$	M	$M_1$	$N_2$
01	0.5	6	16.8	11	13.5	13	6	6	6	28	19.5	3.1	2 x 2.1	5.3	4.5	4.8	9.3	9.3	17.3
02	0.75	6	20	13	16	14	8	6	6	32	23	3.1	3 x 2.6	6	5	7.8	12.1	12.1	19.8
03	1.5	8	23	19	22	18	10	10	10	40	30	3.1	3 x 3.1	6	5.5	9.1	14.7	14.7	23
05	3	10	28	26	24	28	15	17	15	50	38	3.1	3 x 3.1	6.5	5.5	8.8	15	15	26.1
06	7	15	36	35	32	-	18	20	-	63	50	5.2	3 x 4.1	10	8	-	18.8	-	24
07	15	20	45	42	38	-	22	25	-	80	60	5.2	3 x 4.1	11	8	-	24.3	-	26.5

SIZE	$O_5$	P	$P_2$	$P_4$	Q	R	$R_1$	S	$S_2$	$S_5$	T	U	$V_1$	X	Z	$Z_1$	Weight [kg]	
																	110	130
01	3.6	1	1.5	8	3	2.3	4.3	7	23.5	9.4	31	17	2.5	0.1	M3	M3	0.1	0.1
02	5	1.3	1.5	8	3	2.1	4.1	10	26.2	12.25	34	21	4	0.15	M3	M3	0.1	0.1
03	5.1	1.5	1.5	8	3	2.7	5.3	12	30.4	14.85	43	23	5	0.15	M4	M4	0.2	0.2
05	7.8	1.5	1.5	8	3	3	6	12	34.1	15.2	54	32	5	0.2	M4	M5	0.35	0.4
06	6	2	2.5	12	7	3.8	7.3	15	33	-	67	41	6	0.2	M4	M6	0.5	0.5
07	7	2	2.5	12	7	4.3	8.3	20	38	-	85	50	8	0.2	M6	M6	0.9	1

available shaft diameters page 51

All dimensions in mm keyway according to DIN 6885/1-P9 Standard voltage 24 V DC VDE 0580, ISO-class „B“ <sup>1)</sup> rated torque after running in process

TABLE (1)

Shaft mounted clutches size 01 ... 07  
COMBINORM C ... 036X0 ...

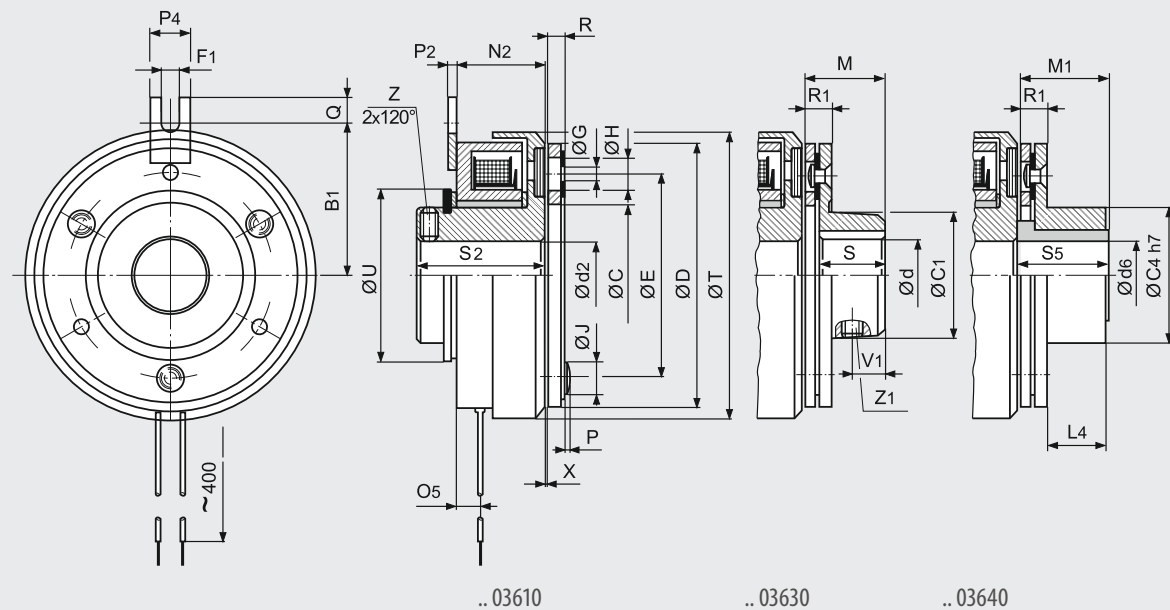

**TABLE(2)**

DIZE	$T_{2N}^{1)}$	$P_{20}$	$A_{h8}$	$A_1$	$B$	$B_1$	$C$	$C_1$	$d$	$d_3$	$D$	$D_2$	$E$	$E_1$	$F$	$F_1$	$G$	$H$	$J$
	[Nm]	[W]							max	max									
06	7	15	80	-	72	-	35	32	18	17	63	-	50	-	4.5	-	3 x 4.1	10	8
07	15	20	100	-	90	-	42	38	22	22	80	-	60	-	5.5	-	3 x 4.1	11	8
08	30	28	-	62.5	-	56	52	48	30	30	100	85	76	45.75	-	6.5	3 x 5.1	11.5	10
09	65	35	-	75	-	68.5	62	58	35	35	125	95	95	55	-	6.5	3 x 6.1	15	11.5
10	130	50	-	95	-	87.5	80	73	45	50	160	126	120	72.5	-	9	3 x 8.1	21	14.5
11	250	68	-	115	-	107.5	100	92	60	50	200	126	158	88	-	9	3 x 10.1	19	17.5
12	500	85	-	145	-	135	125	112	70	60	250	160	210	110	-	11	4 x 12.1	28	20.5

SIZE	$M$	$O_2$	$P$	$P_3$	$P_4$	$P_5$	$R$	$R_1$	$S$	$S_3$	$T$	$V$	$V_1$	$W$	$W_1$	$X$	$Z_1$	Weight [kg]	
																		210/710	230/730
06	18.8	19	2	-	-	4	3.8	7.3	15	41	67	-	6	-	-	0.2	1xM6	0.8	0.9
07	24.3	21.5	2	-	-	4.5	4.3	8.3	20	45	85	-	8	-	-	0.2	1xM6	1.5	1.6
08	31	24	2.5	16.2	12	5.5	6	11	25	51.5	106	M5	10	M4	46.5	0.2	1xM8	2.3	2.5
09	36.9	25	3	18.7	14	5.5	6.9	12.9	30	55	133	M8	12	M5	55	0.3	2xM10	3.7	4.1
10	46.9	31.5	4	21.5	14	7	8.9	15.9	38	65	169	M8	15	M5	72.5	0.3	2xM10	7	7.7
11	59.15	32.5	4.5	23	20	7	11.15	20.15	48	71	212.5	M10	19	M6	88	0.4	2xM12	13.1	14.3
12	68	41	5	41	22	8	13	24	55	85	266	M10	22	M8	110	0.4	2xM12	23	25

available shaft diameters page 51

All dimensions in mm keyway according to DIN 6885/1-P9 Standard voltage 24 V DC VDE 0580, ISO-class „B“ <sup>1)</sup> rated torque after running in process

**TABLE (2)**

Shaft mounted clutches size 06 ... 12

**COMBINORM C ... 03XX0 ...**

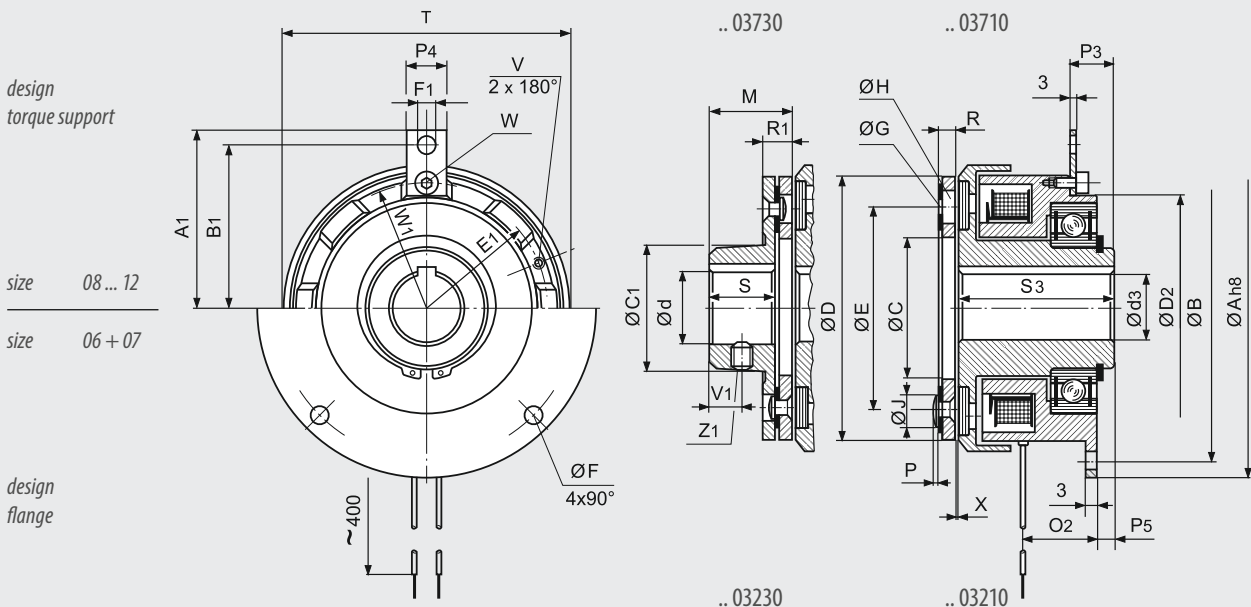

# COMBINORM C

SIZE	$T_{2N}^{1)}$ [Nm]	$P_{20}$ [W]	$T_A^{2)}$ [Nm]	$A_{h8}$	$A_1$	B	$B_1$	$C_5$	D	$D_2$	$D_3$	$D_4$	$d_4$ max	$d_7$ max	d	E	$E_1$	$E_2$	F	$F_1$	G	H	J
06	7	15	10	80	-	72	-	30	63	-	25	29	19	17	16	50	-	44	4x4.5	-	3x4.1	10	8
07	15	20	25	100	-	90	-	40	80	-	35	40	26	25	22	60	-	68	4x5.5	-	3x4.1	11	8
08	30	28	25	-	62.5	-	56	45	100	85	40	46	30	28.5	25	76	45.75	80	-	6.5	3x5.1	11.5	10
09	65	35	50	-	75	-	68.5	60	125	95	50	57	38	33	35	95	55	100	-	6.5	3x6.1	15	11.5
10	130	50	140	-	95	-	87.5	85	160	126	70	76	55	41	50	120	72.5	140	-	9	3x8.1	21	14.5
11	250	68	220	-	115	-	107.5	100	200	126	70	76	65	48	50	158	88	165	-	9	3x10.1	19	17.5
12	500	85	500	-	145	-	135	125	250	160	80	89	85	52	60	210	110	215	-	11	4x12.1	28	20.5

available shaft diameters page 51

All dimensions in mm keyway according to DIN 6885/1-P9 Standard voltage 24 V DC VDE 0580, ISO-class „B“ 1) rated torque after running in process 2) tightening

For flexible clutches (type .. 03840) the following additional instructions are applicable:

The radial and axial screws connecting the rubber element to the hubs must all be tightened to the torque ( $T_A^{2)}$ ) given in the table, using a torque wrench. Ensure that when tightening the screws the aluminium bushes do not twist in the rubber part and that they sit squarely. In order to reduce friction between the screw head and the aluminium bush smear a small amount of grease under the head of the screw before fitting. If necessary use a suitable tool to apply counter pressure on the element to prevent twisting of the rubber part while tightening the screws.

This is particularly important with the radial screws otherwise the curved faces between the aluminium bush and the hub will not engage on the full area but only across the two sides. This will inevitably lead to slackening of the screws and destruction of the clutch. If the clutch is supplied in a pre-assembled state, do not dismantle it, but fit it in this condition.

Shaft mounted clutches with bearing take-up for the output  
**COMBINORM C ... 03810 ...**

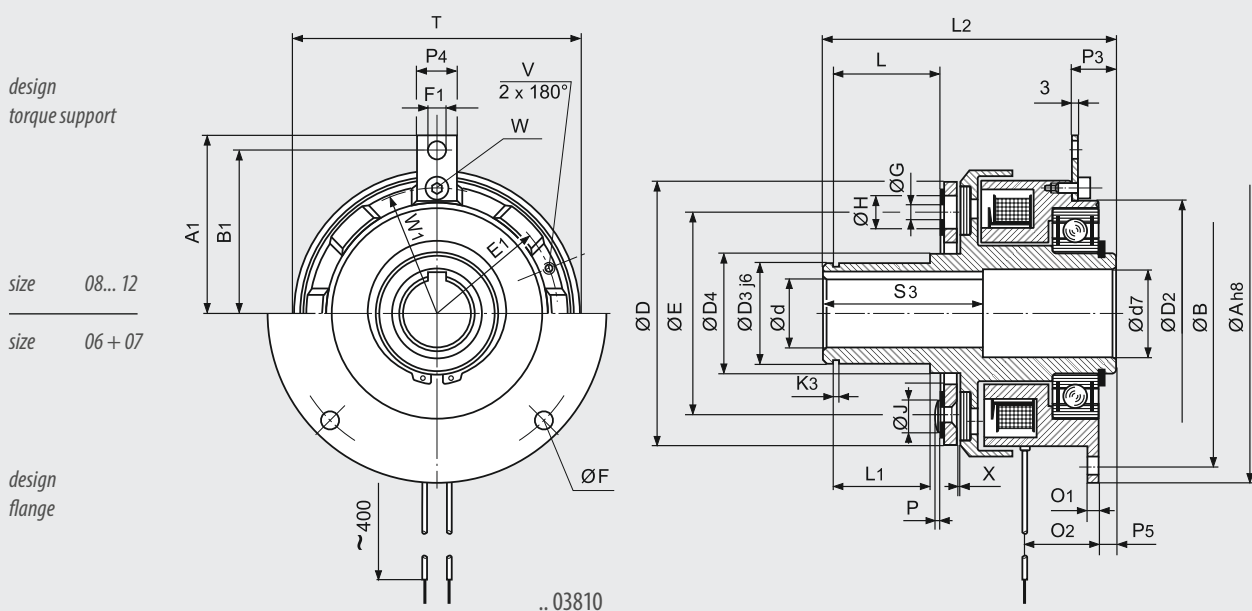

J <sub>3</sub>	K <sub>3</sub>	L	L <sub>1</sub>	L <sub>2</sub>	L <sub>3</sub>	M <sub>2</sub>	M <sub>3</sub>	M <sub>4</sub>	O <sub>1</sub>	O <sub>2</sub>	P	P <sub>3</sub>	P <sub>4</sub>	P <sub>5</sub>	S <sub>3</sub>	T	T <sub>1</sub>	V	W	W <sub>1</sub>	W <sub>2</sub>	X	Z	Weight [kg]	
																								810	840
2	1.3	32.9	25.6	80	117	30	24	19	3	19	2	-	-	4	41	67	56	-	-	-	2xM6	0.2	M5	1	1.7
4	1.6	37.7	29.9	90	129	30	24	20	3	21.5	2	-	-	4.5	45	85	85	-	-	-	2xM8	0.2	M6	1.8	3
4	1.85	35.2	32.15	96	141	35	28	23	-	24	2.5	16.2	12	5.5	51.5	106	100	M5	M4	46.5	3xM8	0.2	M8	2.7	4.1
4	2.15	37.6	34.6	103	160	45	32	31	-	25	3	18.7	14	5.5	55	133	120	M8	M5	55	3xM10	0.3	M10	4.2	7.4
6	2.65	47.8	43.1	126	200	60	46	40	-	31.5	4	21.5	14	7	65	169	170	M8	M5	72.5	3xM14	0.3	M10	8.3	14.6
8	2.65	47.5	43.3	134	217	65	58	40	-	32.5	4.5	23	20	7	82	212.5	200	M10	M6	88	3xM16	0.4	M12	14.5	24.4
8	2.65	59.6	55.3	162	260	80	70	49	-	41	5	27	22	8	85	266	260	M10	M8	110	3xM20	0.4	M12	26	45.2

**SIZE** Compliance [mm] of flexible clutches

SIZE	Compliance [mm] of flexible clutches	
	radial	axial
06	1.5	2
07	1.5	3
08	1.5	3
09	2	4
10	2	5
11	2	5
12	2	5

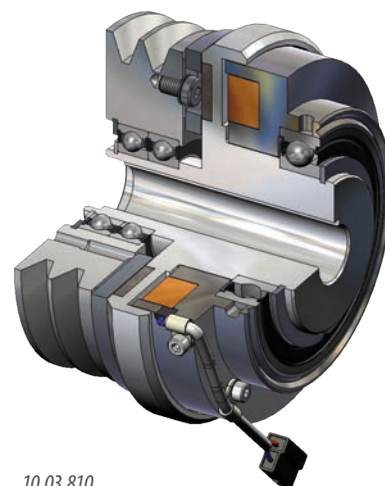

10.03.810

Shaft mounted clutches with flexible clutch

**COMBINORM C ... 03840 ...**

design torque support

size 08... 12

size 06 + 07

design flange

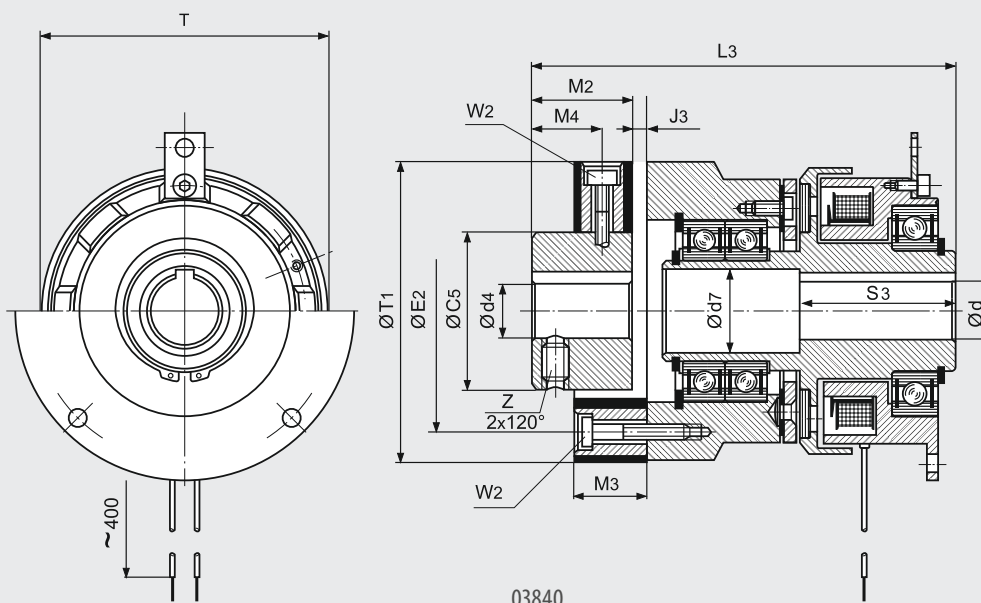

# COMBINORM T

COMBINORM T are electromagnetically operated tooth clutches for wet or dry operation. Torque is transmitted by the leading faces of hardened serrations and is backlash free.

Large torques are transmitted with less space requirements in both directions.

On request available in various special voltages.

**Range of application** e.g. door drives, printing machines, transport roller, aggregate connection

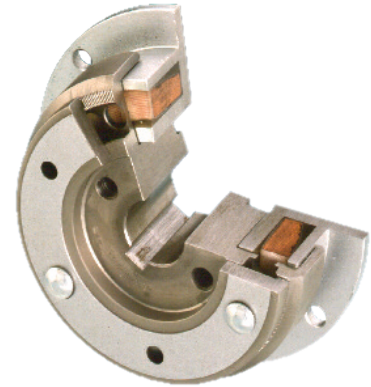

SIZE	T <sub>2N</sub> [Nm]	P <sup>20°C</sup> [W]	A <sub>h8</sub>	A <sub>1</sub>	B	B <sub>1</sub>	C <sup>H8</sup>	C <sub>1</sub>	C <sub>2</sub>	D	d <sub>1</sub> max	D <sub>2</sub>	d <sub>3</sub> max	d max	E	E <sub>1</sub>
06	21	15	80	-	72	-	35	32	36	63	20	-	17	18	50	-
07	45	20	100	-	90	-	42	38	43.5	80	25	-	22	22	60	-
08	90	28	125	62.5	112	56	52	48	53.8	100	30	85	30	30	76	45.75
09	195	35	150	75	137	68.5	62	58	63.8	125	35	95	35	35	95	55
10	390	50	190	95	175	87.5	80	73	82.1	160	50	126	50	45	120	72.5

available shaft diameters page 51

Flange mounted tooth clutch  
**COMBINORM T ... 071X0 ...**

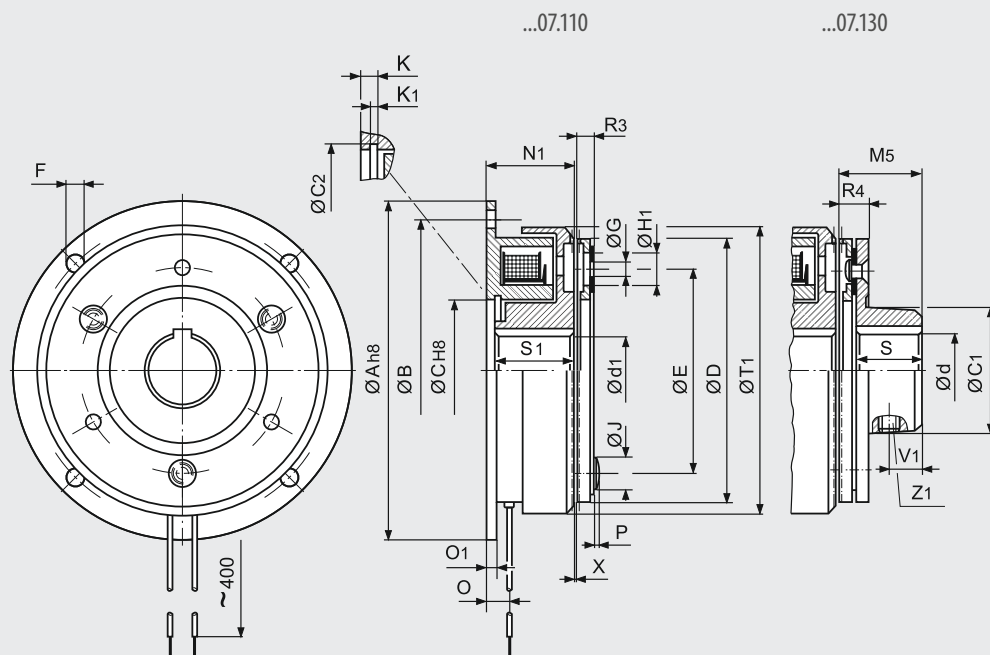



SIZE	F	F <sub>1</sub>	G	H <sub>1</sub>	J	K	K <sub>1</sub>	M <sub>5</sub>	N <sub>1</sub>	O	O <sub>1</sub>	O <sub>2</sub>	P	P <sub>3</sub>	P <sub>4</sub>	P <sub>5</sub>
06	4x4.5	-	3x4.1	8	8	3.5	1.6	20.3	24	6	3	19	2	-	-	4
07	4x5.5	-	3x4.1	8	8	4.25	1.85	26.4	26.5	7	3	21.5	2	-	-	4.5
08	4x6.6	6.5	3x5.1	11.2	10	5	2.15	33.6	30	8	4	24	2.5	16.2	12	5.5
09	4x6.6	6.5	3x6.1	15	11.5	5.5	2.15	41.2	33.5	9	4	25	3	18.7	14	5.5
10	4x9	9	3x8.1	16	14.5	6	2.65	50.8	37.5	11	5	31.5	4	21.5	14	7

SIZE	R <sub>3</sub>	R <sub>4</sub>	S	S <sub>1</sub>	S <sub>3</sub>	T <sub>1</sub>	V	V <sub>1</sub>	W	W <sub>1</sub>	X	Z <sub>1</sub>	weight [kg]			
													210/710	230/730	110	130
06	5.3	8.8	15	22	41	68	-	6	-	-	0.15	1xM6	1	1	0.7	0.7
07	6.4	10.4	20	24	45	86.5	-	8	-	-	0.2	1xM6	1.7	1.8	1.1	1.2
08	8.6	13.6	25	27	51.5	108	M5	10	M4	46.5	0.2	1xM8	2.6	2.8	1.9	2.1
09	11.2	17.2	30	30	55	135	M8	12	M5	55	0.2	2xM10	4.1	4.4	3.2	3.5
10	12.8	19.8	38	34	65	172.2	M8	15	M5	72.5	0.25	2xM10	7.5	8.3	6.1	6.9

All dimensions in mm keyway according to DIN 6885/1-P9 Standard voltage 24 V DC VDE 0580, ISO-class „B“

Shaft mounted tooth clutches  
**COMBINORM T ... 07XX0 ...**

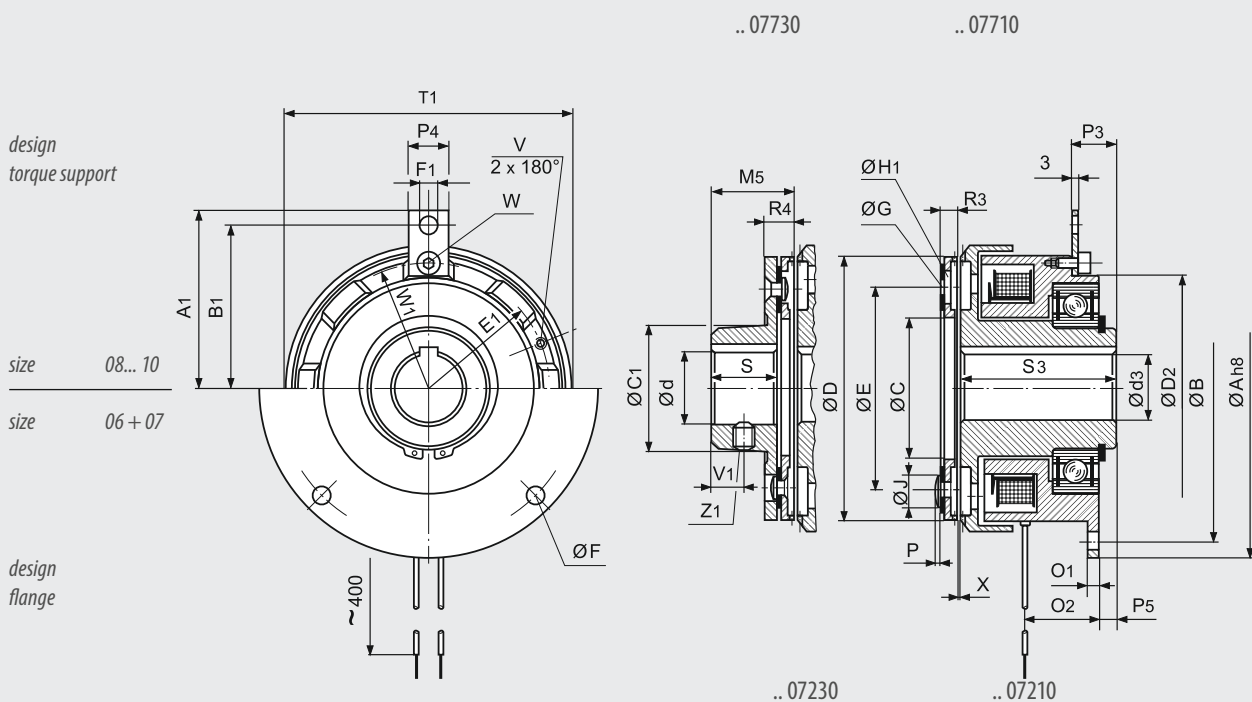

# COMBINORM TECHNICAL DATA

## DC-SIDE SWITCHING

### CURRENT / TIME AND TORQUE / TIME DIAGRAMS

The mentioned designations of switching times are according to DIN VDE 580.

The specified switching times are achieved with adjusted nominal air gap ( $x_{min}$ ). It concerns average values whose scattering depends on the current supply and the coil temperature.

The torques specified in the measuring tables are safely achieved with single-side clutches and brakes after a run-in phase at 100 rpm. In new condition and in case of substantially higher speeds the torques are possibly smaller.

### CURRENT SUPPLY

The COMBINORM requires a DC voltage, which can be made available by different rectifiers, transformer rectifiers as well as electronic switches of the series COMBITRON 91 and 94.

A short-time overvoltage produces very short switching times and high switching accuracies.

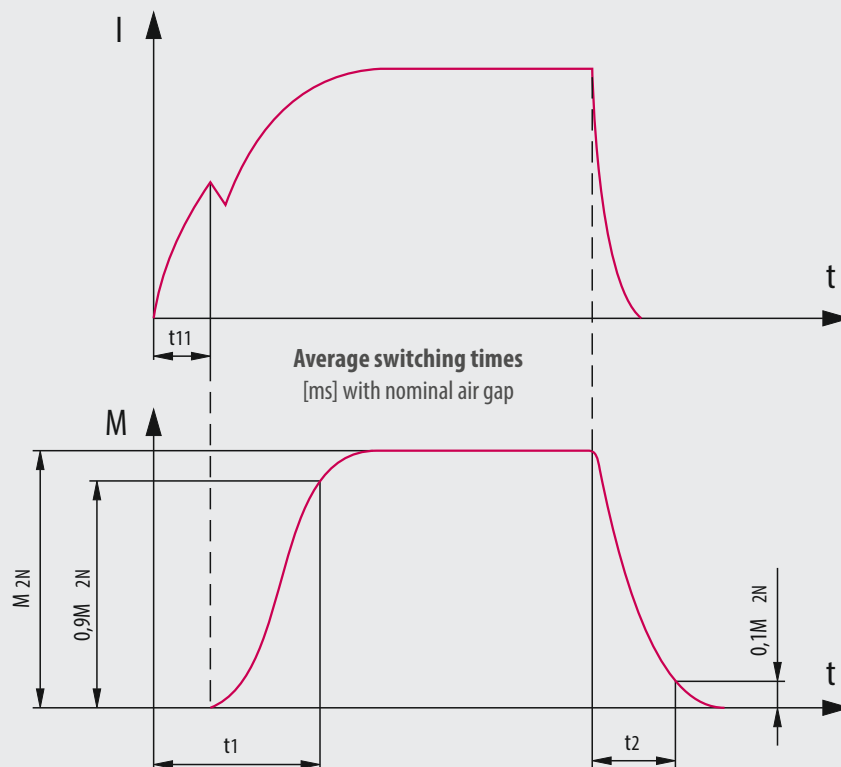

**COMBINORM 02 / 03 / 04 / 07**

SIZE				01	02	03	05	06	07	08	09	10	11	12
<b>T<sub>2N</sub></b>	02/03/04 07	20 °C	[Nm]	0.5	0.75	1.5	3	7 21	15 45	30 90	65 195	130 390	250	500
<b>P<sub>20</sub></b>	02/04 brake 03/04/07 clutch	20 °C 20 °C	[W]	6 6	6 6	8 8	10 10	12 15	16 20	21 28	28 35	38 50	50 68	65 85
<b>J</b>														
<b>Armature</b>	110/210/610/710/810 120/130/230/630/730 320 170		[10 <sup>-4</sup> kgm <sup>2</sup> ]	0.010 0.013	0.014 0.021	0.045 0.068	0.122 0.18	0.366 0.53 0.82 0.99	1.07 1.57 2.6 2.7	3.72 5.29 10.3 9.12	10.6 15.1 27 25.4	40 50.1 101 88.9	115 159 272	311 437 814
<b>Rotor</b>	110/130/140/170/610 630/640 210/230/240/710/730/740 810			0.025 0.027	0.035 0.038	0.15 0.17	0.375 0.4	0.825 0.9 1.02	2.38 2.6 3.05	7.25 8 8.76	21.9 24 26	67.4 73 82.5	200 220 230	450 500 520
<b>W<sub>R max.</sub></b>	02/03/04		[10 <sup>4</sup> J]	0.04	0.05	0.08	0.12	0.19	0.31	0.48	0.75	1.25	2	2.9
<b>W<sub>R 0.1mm</sub></b>	02/03/04		[10 <sup>7</sup> J]	0.23	0.3	0.43	0.63	0.95	1.63	2.53	4.09	6.66	10.4	16.3
<b>P<sub>R max.</sub></b>	02/04 brake 03/04 clutch		[J/s]	12.8 20.3	18.6 28.6	26.9 40.6	38.9 58.3	58.3 80.6	79.2 114	114 161	164 228	236 322	339 458	489 647
<b>Xn<sub>max.</sub> 20°</b>	02/03/04 07		[mm]	0.3	0.45	0.45	0.6	0.7 0.15	0.7 0.2	0.7 0.2	0.9 0.2	1.0 0.25	1.2	1.2
<b>X</b>	02/03/04			0.1	0.15	0.15	0.2	0.2	0.2	0.2	0.3	0.3	0.4	0.4
<b>n<sub>max.</sub></b>	02/03/04/07 <b>EXCEPTION CLUTCH!</b> <b>03.610/630/640</b>		[min <sup>-1</sup> ]	10,000 1,500	10,000 1,500	10,000 1,500	10,000 1,500	8,000 1,500	6,000 1,500	5,000	4,000	3,000	3,000	2,000
<b>Switching times</b>														
<b>Brake 02/04</b>		t <sub>2</sub> DC	[ms]	3	4	5	8	10	15	50	85	100	140	200
		t <sub>2</sub> AC		17	20	25	40	70	95	240	300	400	600	800
	nominal voltage	t <sub>11</sub> =		2	3	3	5	6	8	10	13	15	23	35
		t <sub>1</sub> =		5	8	8	17	24	38	42	48	85	118	155
	3 x nominal voltage	t <sub>11</sub> =		1	2	2	3	3	4	5	6	8	10	16
		t <sub>1</sub> =		3	4	4	8	11	17	20	22	38	50	76
<b>Clutch 03/04</b>		t <sub>2</sub> DC	[ms]	5	6	7	10	14	19	40	68	100	130	200
		t <sub>2</sub> AC		17	19	22	30	39	61	115	220	400	650	900
	nominal voltage	t <sub>11</sub> =		4	5	7	10	14	18	23	25	29	37	55
		t <sub>1</sub> =		10	14	17	32	48	74	81	90	161	201	295
	3 x nominal voltage	t <sub>11</sub> =		2	2	3	5	6	8	10	12	14	16	25
		t <sub>1</sub> =		5	6	7	16	22	33	37	42	69	91	125

**LEGEND**

T <sub>2N</sub>	rated torque after running in process	[Nm]	t	time	[ms]
T <sub>erf</sub>	required torque	[Nm]	t <sub>1</sub>	<b>Engaging time:</b> Time from connecting the current the rated torque is attained	[ms]
J	moment of inertia	[10 <sup>-4</sup> kgm <sup>2</sup> ]	t <sub>11</sub>	<b>Engaging delay time:</b> Time from connecting the current until the torque rises	[ms]
P <sub>20</sub>	power at 20 °C	[W]	t <sub>2</sub>	<b>Release time:</b> Time from disconnecting the current until 0.1 T <sub>2N</sub>	[ms]
n <sub>max</sub>	maximum speed	[min <sup>-1</sup> ]			
X	rated air gap	[mm]			
X <sub>n</sub>	clearance at which an adjustment is recommended	[mm]			
W <sub>Rmax</sub>	permissible friction per switching operation	[10 <sup>4</sup> J]			
W <sub>R0,1</sub>	friction work up to 0,1 mm wear	[10 <sup>7</sup> J]			
P <sub>Rmax</sub>	permissible friction work per second	[J/s]			
I	magnet-rated current	[A]			

# COMBIBOX PROGRAM SCHEDULE

## COMBIBOX CLUTCH-BRAKE-COMBINATION TYPE 10 / 09 / 06

with an energised to engage single sided clutch / brake	<b>COMBIBOX 10</b>	page 37
with an energised to engage single sided clutch without brake	<b>COMBIBOX 09</b>	page 37
with an energised to engage single sides clutch / and energised to disengage single sided permanent magnet brake	<b>COMBIBOX 06</b>	page 37

### TECHNICAL DATA

<b>COMBIBOX</b> shaft in / shaft out	page 38
<b>COMBIBOX</b> bore in / bore out	page 39
<b>COMBIBOX</b> bore in / shaft out	page 40
<b>COMBIBOX</b> shaft in / bore out	page 41
Moments of inertia, friction work and calculations	page 42

On request we adapt the COMBIBOX to your constructional and electrical requirements.

### DESIGN ATTACHMENTS

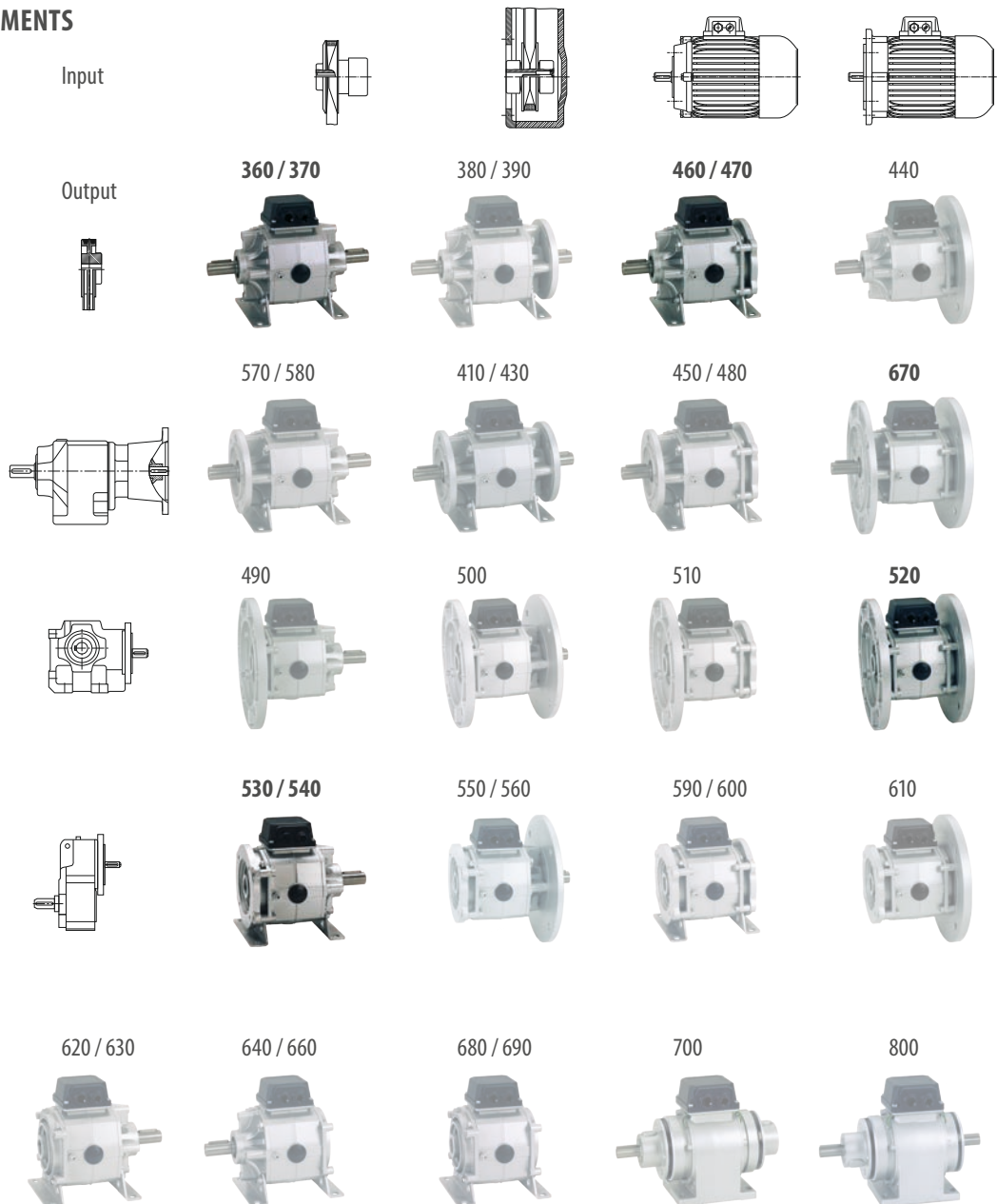

The COMBIBOX is a ready to install electromagnetic actuated clutch-brake module in a single housing.

The modular system is designed for a multitude of variants; these covering most of the applications in the field.

The patented adjustment procedure permits an air gap readjustment in it's installed condition. Thus giving a greater lifetime of the wear affected components.

The units designed for Start-Stop-operation considerably reduce the energy consumption due to a continuously running drive.



**TYPE 10**

has an energise to engage single sided brake, this is the most commonly used, permitting high switching frequency and good positioning accuracy. The COMBITRON rapid switch can be used with this variant to achieve exceptionally high switching frequencies.

The rated torque of both clutch and brake are identical.

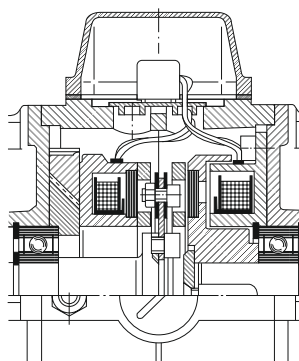

**TYPE 09**

is the COMBIBOX version without brake, i.e. an electrical clutch in a housing for the use between e.g. motor and gear unit.

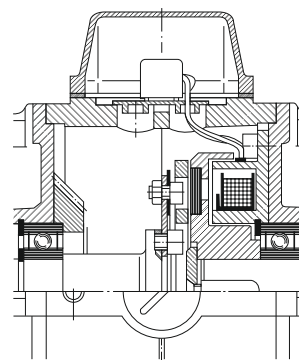

**TYPE 06**

has an energise to disengage permanent magnet single-side brake. The characteristic of this variant is that the position of the output shaft is kept safe and backlash-free in currentless condition. The rated torque of the brake is slightly lower than that of the clutch.

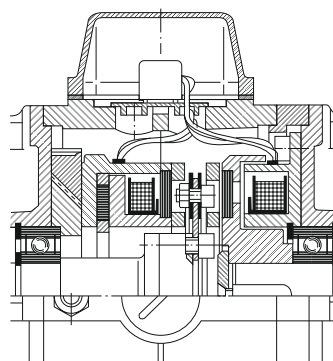

# COMBIBOX SHAFT IN / SHAFT OUT

SIZE	a <sub>3</sub>	a <sub>4</sub>	a <sub>7</sub>	b	c	e	f <sub>2</sub>	f <sub>5</sub>	g	h	h <sub>1</sub>	i	k	k <sub>1</sub>	n	s	s <sub>2</sub>	u	Shaft		Weight [kg]
																			d <sub>1</sub>	l	
06	80	100/109	85	115/124	3	72	100	10	103	63	87	18.4	137/146	117/126	18	7	M6	44	11 14	23 30	2.8/2.9
07	105	115/125	110	138/148	3	90	130	10	125	71	94	22.7	160/170	140/150	25	9	M8	50	14 19	30 40	3.9/4.1
08	130	135/147	140	160/172	4	112	160	12	158	90	108	30.6	196/208	172/184	28	9	M8	62	19 24	40 50	7.7/8.7
09	150	155/169	160	180/194	5	137	180	14	185	100	129	34.4	224/238	196/210	30	11	M10	74	24 28	50 60	12.5/15.0
10	185	185/202	195	215/232	6	175	223	18	236	132	154	50.6	286/303	250/267	38	13	M12	95	28	60	22.5/28.0
11	upon request																				

Alle dimensions in mm keyways according to DIN 6885/1 centerings D according DIN 332/2 standard voltage 24 V DC VDE 0580, ISO-class „B“

## Rated torques type 10 / 09 / 06

SIZE		06	07	08	09	10	11
T <sub>2N</sub> <sup>1)</sup> [Nm]	clutch	7	15	30	65	130	250 / -
	brake	7 / 6	15 / 12	30 / 24	65 / 50	130 / 120	250 / -
P <sub>20</sub> [W]	clutch	15	20	28	35	50	68 / -
	brake	12 / 13	16 / 21	21 / 20	28 / 30	38 / 50	50 / -

<sup>1)</sup> rated torque after running in process

variations type 06 (marked in red)

## PART NO.

	feet	input flange B5 (1)	output flange B5 (1)
-----360			
-----370	X		
-----380		X	
-----390	X	X	
-----410		X	X
-----430	X	X	X
-----570			X
-----580	X		X



Design  
Type  
Size

## ORDERING EXAMPLE:

Size 06 10 430 Design  
Type  
V DC, Ø a<sub>r</sub>, Ø d<sub>1</sub> ?

## Ordering specification:

- part number
- diameter of input-side flange
- diameter of input-side shaft
- diameter of output-side shaft
- diameter of output-side flange
- operating voltage of COMBIBOX
- flange dimensions on page 43

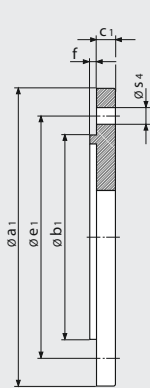

Flange B5 (1)

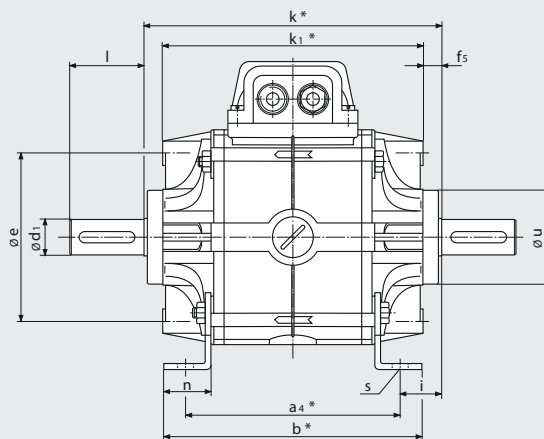

output ← input



Flange B5 (1)

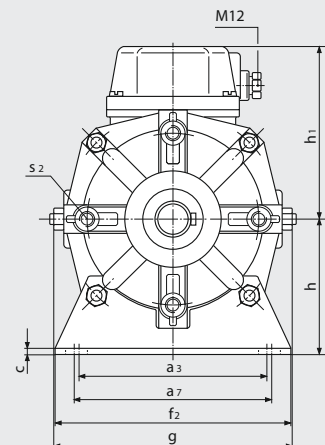

Flange dimensions page 43



SIZE	a <sub>3</sub>	a <sub>4</sub>	a <sub>5</sub>	a <sub>7</sub>	b	b <sub>4</sub> h8	c	d <sub>2</sub> G7 <sub>max</sub>	d <sub>3</sub> G7 <sub>max</sub>	e <sub>3</sub>	f <sub>2</sub>	f <sub>6</sub>			Preferential-bore d <sub>2</sub> and d <sub>3</sub>
06	80	100/109	104	85	115/124	60	3	15	15	108	100	4			11 or 14
07	105	115/125	123	110	138/148	70	3	24	24	128	130	4			14 or 19
08	130	135/147	155	140	160/172	80	4	28	28	165	160	4			19 or 24
09	150	155/169	178	160	180/194	95	5	35	35	190	180	5			24 or 28
10	185	185/202	229	195	215/232	110	6	42	42	242	223	5			28
11	upon request														

All dimensions in mm keyways according to DIN 6885/1 centerings D according DIN 332/2 standard voltage 24 V DC VDE 0580, ISO-class „B“

SIZE	g	h	h <sub>1</sub>	k <sub>4</sub>	l <sub>1</sub>	l <sub>2</sub>	l <sub>3</sub>	n	s	s <sub>6</sub>	v	a			Weight [kg]
06	103	63	87	101 / 110	50	57	9	18	7	5.5	30	60			2.7 / 3.1
07	125	71	94	108 / 118	52	61	9	25	9	6.5	35	60			3.7 / 4.5
08	158	90	108	132 / 144	63.5	75	11	28	9	8.5	45	64			7.5 / 8.9
09	185	100	129	153 / 167	74	86	13	30	11	8.5	50	62			12.0 / 14.5
10	236	132	154	175 / 192	86	102	17	38	13	10.5	70	60			20 / 25.5
11	upon request														

variations type 06 (marked in red)

PART NO.	feet	input flange		outout flange	
		B5 (2)	B14 (3)	B5 (2)	B14 (3)
-----510			X	X	
-----520		X	X	X	
-----590			X		X
-----600	X		X		X
-----610		X			X
-----680					
-----690	X				

Design Type Size

### ORDERING EXAMPLE:

Size 06 10 600 Design  
 Type  
 V DC, Ø a<sub>7</sub>, Ø d<sub>1</sub> ?

### Ordering specification:

- part number
- diameter of input-side flange
- diameter of input-side bore
- diameter of output-side bore
- diameter of output-side flange
- operating voltage of COMBIBOX
- flange dimensions on page 43

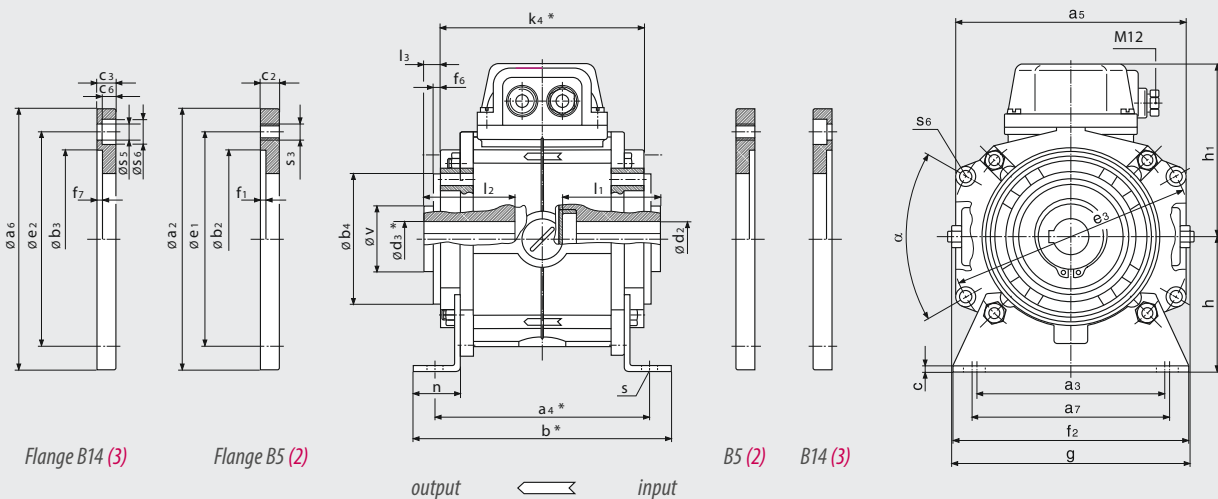

Flange dimensions page 43

# COMBIBOX BORE IN / SHAFT OUT

SIZE	a <sub>3</sub>	a <sub>4</sub>	a <sub>5</sub>	a <sub>7</sub>	b	b <sub>4</sub> h8	c	d <sub>2+3</sub> G7 <sub>max</sub>	e	e <sub>3</sub>	f <sub>2</sub>	f <sub>5</sub>	f <sub>6</sub>	g	h	h <sub>1</sub>	i
06	80	100/109	104	85	115/124	60	3	15	72	108	100	10	4	103	63	87	18,4
07	105	115/125	123	110	138/148	70	3	24	90	128	130	10	4	125	71	94	22,7
08	130	135/147	155	140	160/172	80	4	28	112	165	160	12	4	158	90	108	30,6
09	150	155/169	178	160	180/194	95	5	35	137	190	180	14	5	185	100	129	34,4
10	185	185/202	229	195	215/232	110	6	42	175	242	223	18	5	236	132	154	50,6
11	upon request																

Alle dimensions in mm keyways according to DIN 6885/1 centerings D according DIN 332/2 standard voltage 24 V DC VDE 0580, ISO-class „B“

## Rated torques type 10 / 09 / 06

SIZE		06	07	08	09	10	11
T <sub>2N</sub> <sup>1)</sup> [Nm]	Clutch	7	15	30	65	130	250 / -
	Brake	7 / 6	15 / 12	30 / 24	65 / 50	130 / 120	250 / -
P <sub>20</sub> [W]	Clutch	15	20	28	35	50	68 / -
	Brake	12 / 13	16 / 21	21 / 20	28 / 30	38 / 50	50 / -

<sup>1)</sup> Nennmoment nach Einlauf

## PART NO.

PART NO.	feet	input flange		output flange
		B5 (2)	B14 (3)	B5 (1)
----- 440		X		
----- 450			X	X
----- 460			X	
----- 470	X		X	
----- 480	X		X	X
----- 640				
----- 660	X			
----- 670		X		X

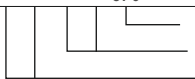

Design  
Type  
Size

## ORDERING EXAMPLE:

Size **06** **10** **450** Design  
Type  
V DC, ø a<sub>6</sub>, ø a<sub>7</sub>, ø d<sub>1</sub> ?

## Ordering specification:

- part number
- diameter of input-side flange
- diameter of input-side bore
- diameter of output-side shaft
- diameter of output-side flange
- operating voltage of COMBIBOX
- flange dimensions on page 43

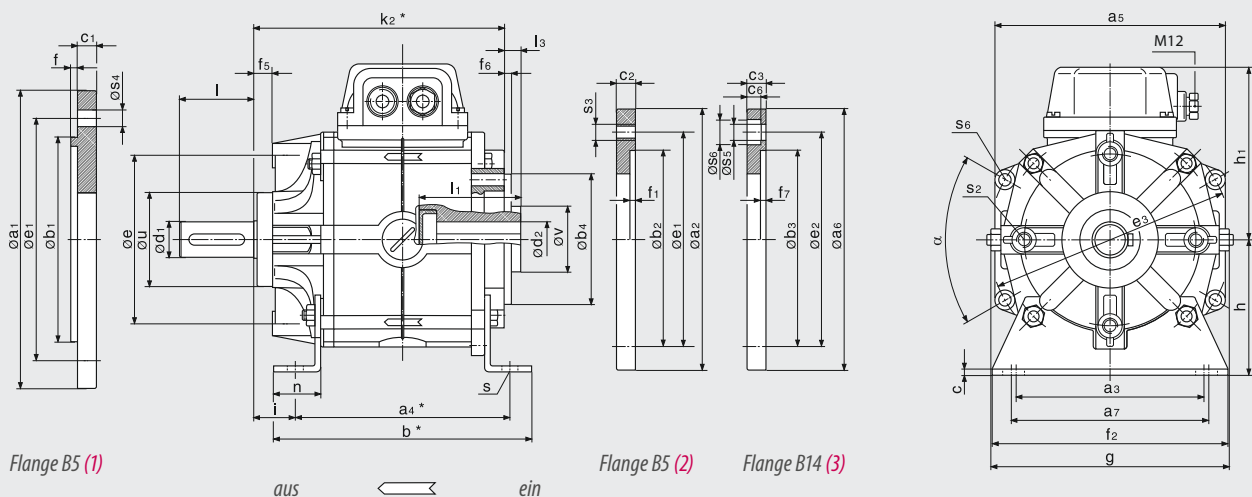

Flange B5 (1)

Flange dimensions page 43

$k_2$	$l_1$	$l_3$	n	s	$s_2$	$s_6$	u h8	v	$\alpha$	Vorzugsbohrung	Welle		Gewicht [kg]
										$d_2$ und $d_3$	$d_1$ k6	l	
119/128	50	9	18	7	M6	5,5	44	30	60	11 oder 14	11 14	23 30	2,8/3,1
134/144	52	9	25	9	M8	6,5	50	35	60	14 oder 19	14 19	30 40	3,9/4,5
164/176	63,5	11	28	9	M8	8,5	62	45	64	19 oder 24	19 24	40 50	7,7/8,9
189/203	74	13	30	11	M10	8,5	74	50	62	24 oder 28	24 28	50 60	12,5/14,5
231/248	86	17	38	13	M12	10,5	95	70	60	28	28	60	22,5/26,0

variations type 06 (marked in red)

ARTIKELNUMMER	feet	input flange B5 (1)	output flange B5 (2) B14 (3)
-----490			X
-----500		X	X
-----530			
-----540	X		X
-----550		X	X
-----560	X	X	X
-----620			
-----630	X		

Design  
Type  
Size

### ORDERING EXAMPLE:

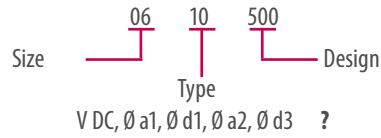

### Ordering specification:

- part number
- diameter of input-side flange
- diameter of input-side shaft
- diameter of output-side bore
- diameter of output-side flange
- operating voltage of COMBIBOX
- flange dimensions on page 43

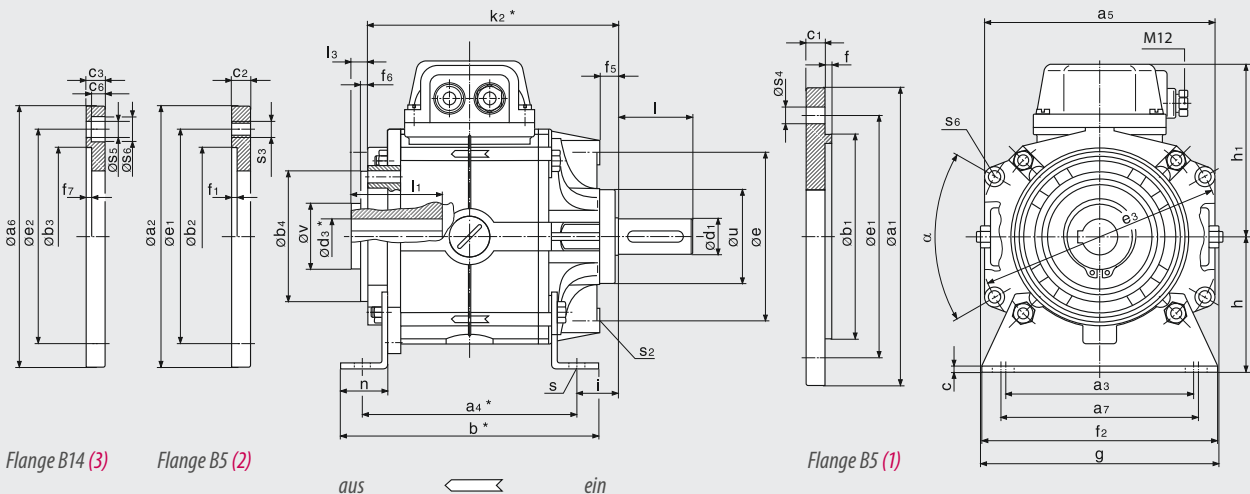

Flange dimensions page 43

# COMBIBOX TECHNICAL DATA

## COMBIBOX 06 / 09 / 10

Size	Type		06	07	08	09	10	11	
$T_{2N}^{2)}$	Clutch	06/09/10	[Nm]	7	15	30	65	130	250
	Brake	10		7	15	30	65	130	250
		06		6	12	24	50	120	
$P_{20}$	Clutch	06/09/10	[W]	15	20	28	35	50	68
	Brake	10		12	16	21	28	38	50
		06		13	21	20	30	50	
$J^{1)}$	Rotor	06/09/10	$[10^{-4}kgm^2]$	1,07	2,98	7,78	23,29	67,4	220
	Armature	06/10		0,84	2,62	8,59	23,08	91,07	330
	Armature	09		0,80	1,2	4,8	12,61	54,3	190
$W_{Rmax}$		06/09/10	$[10^3J]$	1,9	3,1	4,8	7,5	12,5	20,0
$W_{R0,1mm}$	Clutch	06/09/10	$[10^6J]$	9,5	16,3	25,3	40,9	66,6	104
	Brake	06/10		9,5	16,3	25,3	40,9	66,6	104
$P_{Rmax.}$	Clutch	06/09/10	[J/s]	81	114	161	228	323	458
	Brake	06/10		59	80	114	164	236	339
X		06/09/10	[mm]	0,2	0,3	0,35	0,35	0,4	0,5
$X_n$		06/09/10	[mm]	0,4	0,6	0,7	0,7	0,8	1,0
$n_{max}$		06/09/10	$[min^{-1}]$	3000	3000	3000	3000	3000	3000

## SWITCHING TIMES

		Type 09/10 rated voltage [ms]				Type 06 rated voltage [ms]			
Clutch		$t_{11}$	$t_1$	$t_2$	$t_1$	$t_{11}$	$t_1$	$t_2$	$t_1$
Brake		$t_2$		$t_{11}$	$t_1$	$t_{11}$		$t_2$	$t_1$
Size	06	18	55	15	45	20	50	10	45
	07	25	95	20	60	25	85	14	50
	08	40	125	30	110	40	100	22	68
	09	50	200	40	160	50	200	30	150
	10	60	250	45	220	85	250	40	180
	11	100	300	80	260				

$J^{1)}$	= moment of inertia	[kgm <sup>2</sup> ]	$t_1$	= Engaging time, time until 0.9 $T_{2N}$ is reached	[ms]
$T_{2N}^{2)}$	= rated torque after running in process	[Nm]			
PR	= permissible friction per second	[J/s]			
P20	= power input at 20 °C	[W]	$t_{11}$	= Engaging delay time, time until the armature is attracted	[ms]
WR	= friction	[J]			
WR0,1	= friction work until an abrasion of 0,1 mm is reached	[J]			
X	= rated air gap	[mm]	$t_2$	= Release time, time until the armature is attracted to the opposing side.	[ms]
$X_n$	= clearance at which a readjustment is recommende	[mm]			

- 1) Sum of the moment of inertia reduced to the speed of the COMBIBOX plus the moment of inertia of the COMBIBOX parts to be accelerated or decelerated (J).
- 2) The rated torques listed are safely attained after a run-in phase at 100 rpm. In new condition and for substantially higher speeds the torques are possibly lower.

## POWER SUPPLY

COMBIBOX requires d.c. voltage for actuation. The rated voltage of the magnets is 24 V DC standard. For operation with rectifiers the magnets are available in other voltages on specification. The permanent-magnet brake installed in type 06 requires a smoothed supply voltage. To ensure a safe function in case of large temperature fluctuations, we recommend the supply of the coil with constant current.

Single-way or bridge rectifiers of the series COMBITRON 91 can be installed in the terminal box. Trafo rectifiers, electronic switches and rapid switches are also available.

# COMBIBOX FLANGE DIMENSIONS

SIZE	IEC Ø <sup>1)</sup>	a1 (1)	a2 (2)	a6 (3)	b1 (1) h8	b2 (2) +0.3 +0.2	b3 (3) H8	c1 (1)	c2 (2)	c3 (3)	c6 (3)
06	90	90	105	105	60	60	60	10	10	10	5.5
	105	105	105	105	70	70	70	10	10	10	6.5
	120	120	120	120	80	80	80	10	10	10	6.5
	140	140	140	140	95	95	95	10	10	12	8.0
	160	160	160	160	110	110	110	10	12	12	8.0
07	105	110	120	120	70	70	70	10	10	10	6.5
	120	120	120	120	80	80	80	10	10	10	6.5
	140	140	140	140	95	95	95	10	10	10	6.0
	160	160	160		110	110		10	12		6.0
	200	200	200		130	130		10	14		8.0
08	120	130	-	160	80		80	12		12	6.5
	140	140	160	160	95	95	95	12	12	12	6.0
	160	160	160	160	110	110	110	12	12	12	6.0
	200	200	200	200	130	130	130	12	14	14	7.0
	250	250	250	-	180	180		12	14		
09	140	160	160	160	95	95	95	14	14	14	9.0
	160	160	160	160	110	110	110	14	14	14	9.0
	200	200	200	200	130	130	130	14	14	14	
	250	250	250	250	180	180	180	14	14	14	
10	160	-	200	200		110	110		18	18	9.0
	200	210	200	200	130	130	130	18	18	18	8.0
	250	250	250		180	180		18	18		
	300	300	300		230	230		18	18		
	350	350			250			20			
11	250	250	268		180	180		20	25		
	300	300	300		230	230		20	25		
	350	350	350		250	250		20	25		
SIZE	IEC Ø <sup>1)</sup>	e1 (1+2)	e2 (3)	f (1)	f1 (2)	f7 (3)	s3 (2)	s4 (1)	s5(3)	s6 (3)	Weight (1/2/3) [kg]
06	90	75	75	2.5	3	3	M5	5.5	5.5	10	0.16
	105	85	85	2.5	3.5	3	M6	7.0	6.5	11	0.17
	120	100	100	3	3.5	3.5	M6	6.5	6.5	11	0.2
	140	115	115	3	3.5	3.5	M8	9	8.5	14	0.28
	160	130	130	3.5	4	4	M8	9	8.5	14	0.45
07	105	85	85	2.5	3.5	3	M6	M6	6.5	11	0.21
	120	100	100	3	3.5	3.5	M6	6.5	6.5	11	0.22
	140	115	115	3	3.5	3.5	M8	9	9	14	0.3
	160	130		3.5	4		M8	9		14	0.33
	200	165		3.5	4		M10	11		18	0.55
08	120	100	100	3		3.5		7	6.5	11	0.45
	140	115	115	3	3.5	3.5	M8	9	9	14	0.48
	160	130	130	3.5	4	4	M8	9	9	14	0.5
	200	165	165	3.5	4	4.5	M10	11	14	18	0.8
	250	215	215	4	4.5		M12	14			1.4
09	140	115	115	3		3.5		9	9	15	0.5
	160	130	130	3.5	4	4	M8	9	9	15	0.55
	200	165	165	3.5	4	4	M10	11	11		0.63
	250	215	215	4	4.5	4.5	M12	14	14		0.95
10	160		130		4.5	4.5	M8		9	15	0.9
	200	165	165	4	4.5	4	M10	11	11	18	1.1
	250	215		4	4.5		M12	14			1.2
	300	265		4	5		M12	14			1.25
	350	300		5				18			6.5
11	250	215		4	4.5		M12	14			
	300	265		4	4.5		M12	14			
	350	300		5	5.5		M16	18			

<sup>1)</sup> according DIN IEC 34 standard flange

# COMBITRON PROGRAM SCHEDULE

COMBITRON are supply and actuator modules for the electromagnet clutches and brakes. As power supply for DC- or AC-side switching different single-wave and bridge rectifiers as well as rapid switchgear of the series COMBITRON are available.

The rectifiers correspond to the low voltage regulation 73/231/EWG of the European Union.

## COMBITRON RECTIFIERS AND SWITCHES

Half-wave and bridge rectifiers from	0 ... 720 V AC	page 44	<b>COMBITRON 91</b>
Electronic rapid switch up to	50 W	page 46	<b>COMBITRON 94</b>
Rapid-switching rectifier (for COMBISTOP)		page 47	<b>COMBITRON 98</b>

## TECHNICAL DATA

Switching mode (AC- / DC-side switching)

Seite 48

COMBITRON 91 are rectifiers for power supply of brakes and clutches. AC voltage supply max 720 V AC for AC or DC side switching conform to the low voltage regulation 72/231 EWG of the European Union.

Harmful electromagnetic interferences arise at the switching of electromagnetic clutches and brakes and other inductive DC consumers. The half-wave rectifier 0291010-CEMV limits these interferences to class A according to EN 55011.

All other rectifiers are not equipped with measurements to suppress radio interference. This has to be taken into consideration for the planning of the interference suppression of the plant or the machine. The user is responsible for meeting the EU machine directive.





	275 V AC +0%	500 V AC +0%	600 V AC +0%	720 V AC +0%
$U_{in}$	275 V AC +0%	500 V AC +0%	600 V AC +0%	720 V AC +0%
Switching	AC/DC	AC/DC	AC	AC
$U_{vmax}$	450 V	900 V	1000 V	1600 V
Half wave <sup>4)</sup>	0291010-CE07 <sup>2)</sup>	0491010-CE07 <sup>3)</sup>	0591010-CE09 <sup>2)</sup>	0691010-CE09 <sup>3)</sup>
$U_{out} = 0,45 * U_{in}$				
$I_N (45 °C) = 1,0A$				
$I_N (80 °C) = 0,5A$				
Fullwave <sup>4)</sup>	0291020-CE07 <sup>2)</sup>	0491020-CE07 <sup>3)</sup>		
$U_{out} = 0,9 * U_{in}$				
$I_N (45 °C) = 2,0A$				
$I_N (80 °C) = 1,0A$				
Half wave with EMC protection <sup>1)</sup>	0291010-CEMV <sup>3)</sup>			
$U_{out} = 0,45 * U_{in}$				
$I_N (45 °C) = 1,0A$				
$I_N (80 °C) = 0,5A$				

$U_{in}$  maximum input voltage  
 $U_{vmax}$  maximum cut-off voltage  
 $U_{out}$  Output DC voltage  
 AC AC switching  
 DC DC-side switching  
 $I_N (45 °C)$  Rated output current at the temperature

### CHARACTERISTICS

- UL - certification (No.: E.308765)
- compact design in a plastic housing
- possible installation into the motor terminal box
- protection against voltage peaks of the switching contacts
- maximal ambient temperature 80 °C

<sup>1)</sup> with internal interference suppression according to EN 55011/ class A

<sup>2)</sup> picture 1 <sup>3)</sup> picture 2

<sup>4)</sup> different values (U, A) when used under UL conditions

Nominal voltage magnet	Coil voltage tolerance	AC voltage supply	Type of rectifier	
	$U_2 (U_{out})$	$U_1 (U_{in})$		
24 V DC				
105 V DC	93 - 118	230 V AC	half wave rectifier	(0291010-CE07)
205 V DC	182 - 230	230 V AC	full wave rectifier	(0291020-CE07)
180 V DC	162 - 198	400 V AC	half wave rectifier	(0491010-CE07)

picture 1

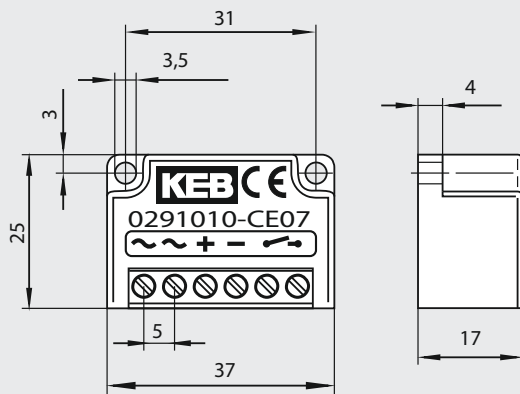

Terminal cross section 1,5 mm<sup>2</sup>

picture 2

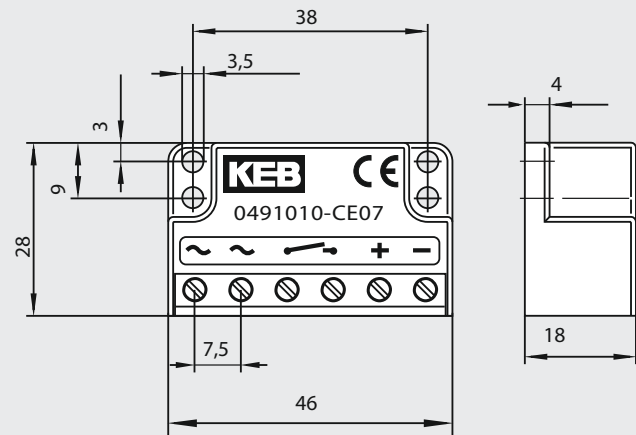

Terminal cross section 2,5 mm<sup>2</sup>

# COMBITRON 94

COMBITRON 94 for the power supply / actuator of two consumers. The output current control ensures a constant magnetic flux and permits short-time overexcitations for shorter switching processes, i.e. improved repeat accuracy.

The main field of application is the interconnection of clutch-brake-combinations COMBIBOX and is used whenever high switching frequencies and positioning accuracy are demanded. The primary feature is the current regulation of 24 V DC supply of electromagnets.

## FEATURES

- circuit board is supplied inclusive holder and slide-in device
- connection according to DIN 41612
- Vadjustment of the deceleration time by potentiometer from 0 ... 1 second
- power supply of the circuit board via separate transformer  
input voltage: 230/400/460 V AC
- power range 15 ... 50 W
- digital inputs
- relay output

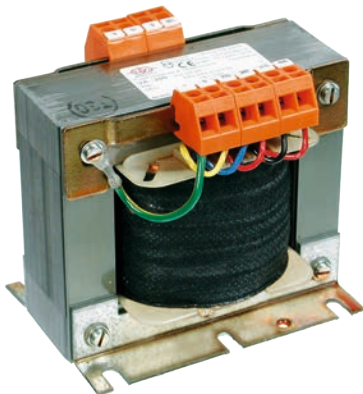

Transformer 0094006-0100



Switcher 0094006-0004

COMBITRON 98 rapid-switching rectifiers with overexcitation for optimal turn-on and turn-off times of spring-applied brakes and electromagnets. Two Powerbox versions with similar right housing to fit on DIN rail or bolt on version.

COMBITRON 9098200-CE09 UL - certification (No.: E.308765)



	9098210-CE04	9098200-CE09 <sup>1)</sup>
Input voltage	24 V DC $\pm 20\%$	180-300 V AC $\pm 0\%$
Overexcitation time	800 ms $\pm 15\%$	350 ms $\pm 10\%$
Cable length	max. 10 m to brake coil	max. 100 m to brake coil
Current I <sub>N</sub> 45 °C	1,2 A continuous 7 A for 800 ms	1,2 A continuous 2,4 A for 350 ms
Current I <sub>N</sub> 75 °C	0,6 A continuous 3,5 A for 800 ms	0,7 A continuous 1,4 A for 350 ms
Temperature	CCV -40° ... 75°	CCV -40° ... 75°
Switching rate	max. 6 per minute at max current	max 1 per minute at max current
Side altitude above sea level	> 1.000 m - 1 % current reduction/100 m	> 1.000 m - 1 % current reduction/100 m
Wiring diagrams		

<sup>1)</sup> different values (U, A) when used under conditions of UL

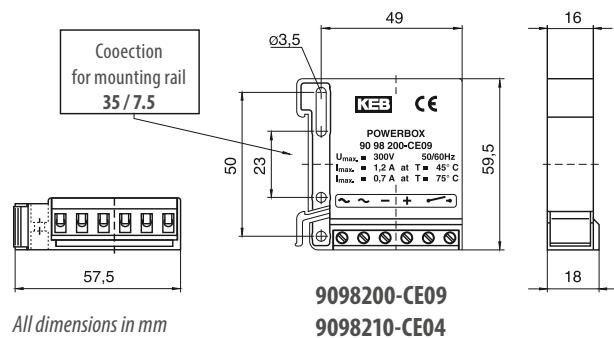

# COMBITRON SWITCHING ARRANGEMENTS

## AC-SIDE SWITCHING

When switching before the rectifier on the AC-side the magnetic field decays slowly. At this mode of switching the tripping delay is quite long. The AC-side switching requires no protective measurements for the coil and the switching contacts. On disconnection the rectifier diodes act as free-wheeling diodes.

The switching times  $t_{11}$  for AC-side switching increase when the rectifier is connected directly in the motor terminal box (2). When the motor slows down a generative voltage is applied to the motor terminals. The wiring (2 and 3) is not permitted for frequency inverter operation.

For line lengths of more than 10 m between rectifier and brake at AC-side switching the regulations prescribe the use of a separate switch (1). In this case the supply voltage may not be tapped behind the motor contactor (2). If it is not possible to install an additional switch the use of special rectifiers becomes necessary.

### CURRENT-TIME-/VOLTAGE-TIME-/ TORQUE-TIME-DIAGRAM

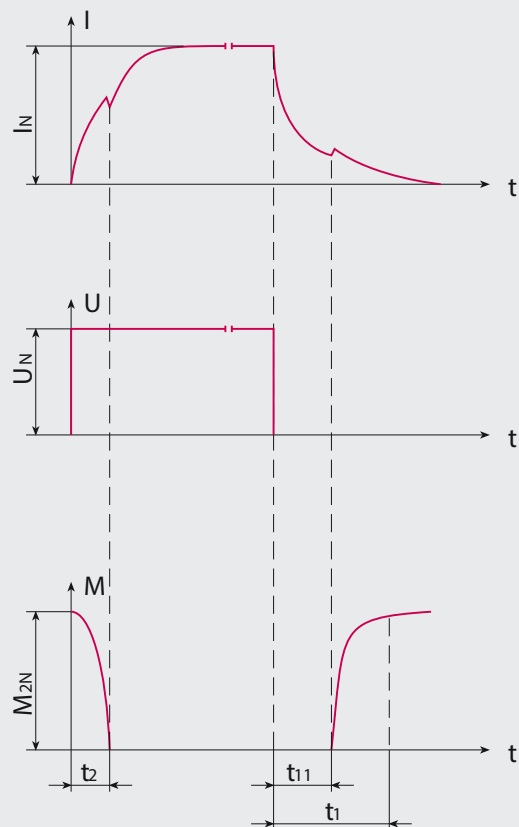

$t_1$  = Engagement time  
 $t_{11}$  = Engagement delay time  
 $t_2$  = Release time

### WIRING DIAGRAM

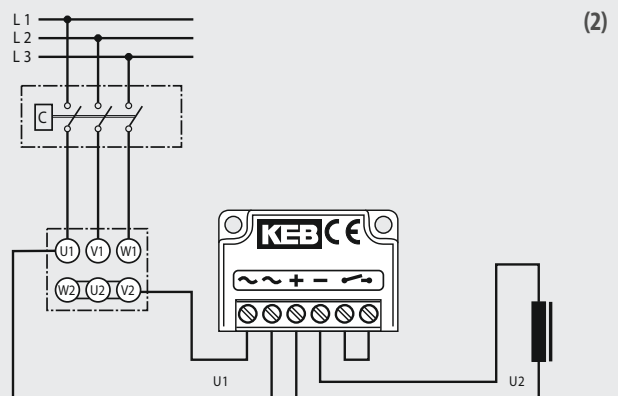
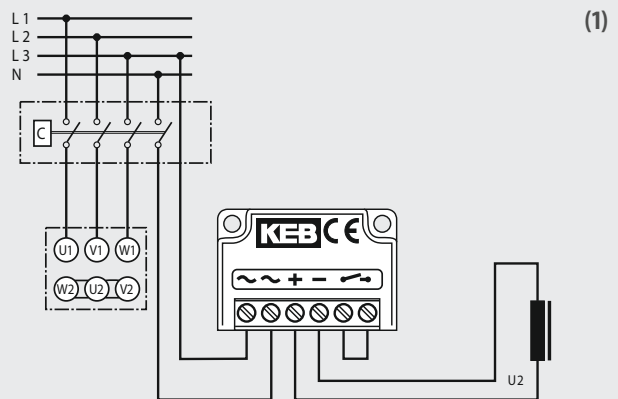

## DC-SIDE SWITCHING

The switching is done between the rectifier and the magnet. At this mode of switching the tripping delay is short, since the energy of the magnetic field is absorbed by the rectifier. The voltage peaks that occur at switching are limited to a harmless level for the rectifier.

The maximal permissible switching frequency for the DC-side switching of rectifiers depends on the energy content of the magnet for COMBISTOP. Higher switching frequencies are achieved by the external connection of a varistor in parallel to the brake or to the terminals + and - DC of the rectifier.

Rectifier	KEB-article	varistor
0291	0090045-2753	S20K275
0491	0090045-6251	S20K625
0591	0090045-6251	S20K625

### CURRENT-TIME-/VOLTAGE-TIME-/ TORQUE-TIME- DIAGRAM

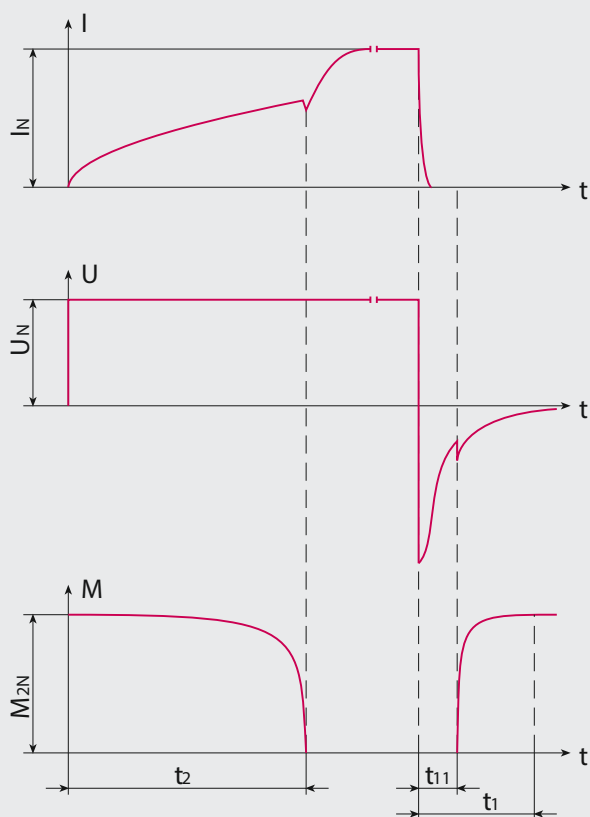

### WIRING DIAGRAM

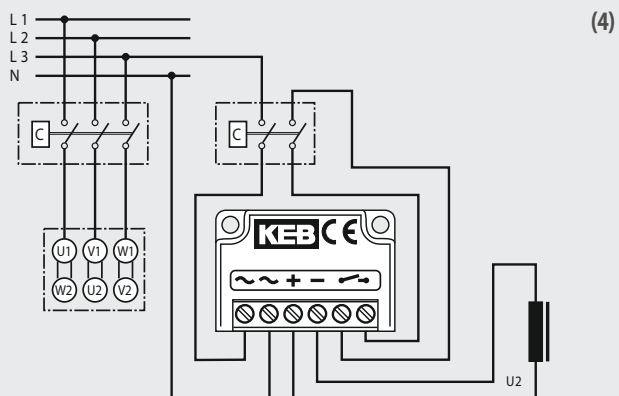
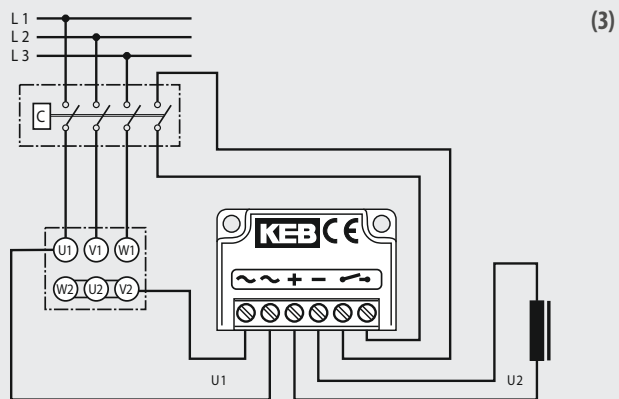

The simultaneous AC and DC-side switching, shown in example 4 guarantees short disconnecting times and reduces the contact erosion.

# DIMENSIONING / CALCULATIONS

Decisive for the dimensioning of the clutches and brakes are the required torque, thermal load, braking time and service life.

## RATED TORQUE $T_{2N}$

To ensure that brakes and clutches work safely even under extreme conditions, the required torque must be multiplied by a safety factor. The selection of the safety factor depends essentially on the application.

The dynamic torque of a single-disc brake may be substantially lower than the rated torque.

$$T_{2N} = T_{\text{erf}} \cdot K \quad K \geq 2 \quad T_{\text{erf}} = \text{required torque [Nm]}$$

## REQUIRED TORQUE $T_{\text{erf}}$

The required torque very often is a mixture of dynamic and static load. When choosing the sign take into account whether the load torque supports or counteracts the deceleration.

$$T_{\text{erf}} = \begin{matrix} T_A \pm T_L \\ T_A = J \cdot \alpha \end{matrix}$$

## ROUGH DEFINITION OF THE REQUIRED BRAKING TORQUE

If the mass moment of inertia is unknown and the driving power is fixed then the required braking torque is calculated as follows:

$$T_{\text{erf}} = 9550 \cdot \frac{P}{n}$$

## THERMAL LOAD

The dimensioning solely on the basis of the required braking torque is permissible only in very few cases. When decelerating the load and the mass moment of inertia is reduced to the brake shaft, the kinetic energy is converted into heat (friction work of the brake). The permissible friction work in dependence on the switching frequency may not be exceeded.

Please note that the maximal permissible friction work is valid only up to the corresponding speed. In case of emergency stop from maximum speed the maximal permissible friction work lies considerably below the values specified in the graphic.

$$W_R = \frac{J \cdot n^2}{182,5} \cdot \frac{T_{2N}}{T_{2N} \pm T_L} \quad WR \leq WR_{\text{max}}$$

## SLIP TIME $t_3$ [MS]

The time from the beginning of the torque rise until attaining the moment of synchronization.

$$t_3 = 104,6 \cdot \frac{J \cdot \Delta n}{T_{2N} \pm T_L} + t_{11}$$

## SERVICE LIFE

The service life depends to a large extent on the peak temperature at braking, which is dependent on the speed, the deceleration time and the current brake torque.

For that reason it is not possible to make universally valid statements with regard to the service life that apply to all operating conditions. Statements to the individual case can be made only when all operating conditions are known. At no time should the friction lining thickness (COMBISTOP) be less than  $g_{\text{min}}$ .

$$L_N = \frac{(X_n - X) \cdot W_{R0,1}}{0,1 \cdot W_R}$$

## ACCELERATION- / DECELERATION TIME

$$t = \frac{J \cdot \omega}{T_{2N} \pm T_L} + t_1$$

### LEGEND

J	= moment of inertia <sup>1)</sup>	[kgm <sup>2</sup> ]
K	= safety factor (K ≥ 2)	[-]
L <sub>n</sub>	= service life until readjustment <sup>2)</sup>	[-]
T <sub>a</sub>	= dynamic braking torque	[Nm]
T <sub>eff</sub>	= required torque	[Nm]
T <sub>L</sub>	= load torque <sup>3)</sup>	[Nm]
T <sub>2N</sub>	= static rated torque <sup>4)</sup>	[Nm]
P <sub>R</sub>	= friction work	[J/S]
P <sub>20</sub>	= power input at 20 °C	[W]
t	= acceleration / deceleration time	
t <sub>1</sub>	= switch on time	[ms]
W <sub>R</sub>	= friction	[J]
W <sub>R0,1</sub>	= friction work up to 0,1 mm wear	[J]
S	= cycles per second	[s <sup>-1</sup> ]
ω	= angular frequency	[s <sup>-1</sup> ]
X	= rated air gap	[mm]
X <sub>n</sub>	= clearance at which an adjustment is recommended	[mm]

### DEVIATIONS COMBIBOX

- <sup>1)</sup> Sum of the moment of inertia reduced to the speed of the COMBIBOX plus the moment of inertia of the COMBIBOX parts to be accelerated or decelerated.
- <sup>2)</sup> Number of switchings until readjustment. For type 06 and 10 the friction T<sub>R</sub> of the clutch as well as the friction T<sub>R</sub> of the brake are to be considered.
- <sup>3)</sup> For the selection of the sign take notice of whether the load torque supports or counteracts the acceleration or deceleration.
- <sup>4)</sup> The rated torques listed in the tables are safely attained after a run-in phase at 100 rpm. In new condition and for substantially higher speeds the torques are possibly lower.

SIZE	ROTOR																					ARMATURE																
			with bearing																																			
			Minimum bore without keyway												Minimum bore without keyway																							
d	a <sup>p9</sup>	b	c	12	11	10	09	08	07	06	05	03	02	01	01	02	03	05	06	07	08	09	10	11	12	12	11	10	09	08	07	06	05	03	02	01		
5																																					5	
6														6	6	6	6																				6	
7	H8	7																																				
8		8																																				
9																																						
10																																						
11																																						
12																																						
14																																						
15																																						
17																																						
18																																						
19																																						
20																																						
22																																						
24																																						
25																																						
28																																						
30																																						
32																																						
35	H7																																					
38																																						
40																																						
42																																						
45																																						
48																																						
50																																						
55																																						
60																																						
65																																						
70																																						
75																																						
80																																						
85																																						
90																																						

All dimensions in mm



# KEB SERVICE

## PERFORMANCE AND COMPETENCE

### AFTER-SALES CUSTOMER SUPPORT

- start-up support
- EMC service
- mains analysis
- Insulation, heat or vibration measurements
- conversion of old product series

### MAINTENANCE AND REPAIRS

- rush or standard service

### COMPONENT AND SPACE PART SUPPLY

- used and new parts for the exchange

### PREVENTIVE MAINTENANCE

- forming and cleaning, inspection, functional analysis

### CUSTOMER SPECIFIC SERVICE

- individual service support
- system optimisation



## KEB WORLDWIDE

**Austria** | KEB Antriebstechnik Austria GmbH  
Ritzstraße 8 4614 Marchtrenk Austria  
Tel: +43 7243 53586-0 Fax: +43 7243 53586-21  
E-Mail: info@keb.at Internet: www.keb.at

**Belgium** | KEB Automation KG  
Herenveld 2 9500 Geraardsbergen Belgium  
Tel: +32 544 37860 Fax: +32 544 37898  
E-Mail: vb.belgien@keb.de Internet: www.keb.de

**Brazil** | KEB South America – Regional Manager  
Rua Dr. Omar Pacheco Souza Riberio, 70  
BR-CEP 13569-430 Portal do Sol, São Carlos Brazil  
Tel: +55 16 31161294 E-Mail: roberto.arias@keb.de

**France** | Société Française KEB SASU  
Z.I. de la Croix St. Nicolas 14, rue Gustave Eiffel  
94510 La Queue en Brie France  
Tel: +33 149620101 Fax: +33 145767495  
E-Mail: info@keb.fr Internet: www.keb.fr

**Germany | Headquarters**  
KEB Automation KG  
Suedstraße 38 32683 Barntrup Germany  
Telefon +49 5263 401-0 Fax +49 5263 401-116  
E-Mail: info@keb.de Internet: www.keb.de

**Germany | Geared Motors**  
KEB Antriebstechnik GmbH  
Wildbacher Straße 5 08289 Schneeberg Germany  
Telefon +49 3772 67-0 Fax +49 3772 67-281  
E-Mail: info@keb-drive.de Internet: www.keb-drive.de

**Italy** | KEB Italia S.r.l. Unipersonale  
Via Newton, 2 20019 Settimo Milanese (Milano) Italia  
Tel: +39 02 3353531 Fax: +39 02 33500790  
E-Mail: info@keb.it Internet: www.keb.it

**Japan** | KEB Japan Ltd.  
15 - 16, 2 - Chome, Takanawa Minato-ku  
Tokyo 108 - 0074 Japan  
Tel: +81 33 445-8515 Fax: +81 33 445-8215  
E-Mail: info@keb.jp Internet: www.keb.jp

**P. R. China** | KEB Power Transmission Technology (Shanghai) Co. Ltd.  
No. 435 QianPu Road Chedun Town Songjiang District  
201611 Shanghai P. R. China  
Tel: +86 21 37746688 Fax: +86 21 37746600  
E-Mail: info@keb.cn Internet: www.keb.cn

**Republic of Korea** | KEB Automation KG  
Room 1709, 415 Missy 2000 725 Su Seo Dong  
Gangnam Gu 135- 757 Seoul Republic of Korea  
Tel: +82 2 6253 6771 Fax: +82 2 6253 6770  
E-Mail: vb.korea@keb.de Internet: www.keb.de

**Russian Federation** | KEB RUS Ltd.  
Lesnaya str, house 30 Dzerzhinsky MO  
140091 Moscow region Russian Federation  
Tel: +7 495 6320217 Fax: +7 495 6320217  
E-Mail: info@keb.ru Internet: www.keb.ru

**Spain** | KEB Automation KG  
c / Mitjer, Nave 8 - Pol. Ind. LA MASIA  
08798 Sant Cugat Sesgarrigues (Barcelona) Spain  
Tel: +34 93 8970268 Fax: +34 93 8992035  
E-Mail: vb.espana@keb.de Internet: www.keb.de

**Switzerland** | KEB Automation AG  
Witzbergstraße 24 8330 Pfaeffikon/ZH Switzerland  
Tel: +41 43 2886060 Fax: +41 43 2886088  
E-Mail: info@keb.ch Internet: www.keb.ch

**United Kingdom** | KEB (UK) Ltd.  
5 Morris Close Park Farm Industrial Estate  
Wellingborough, Northants, NN8 6 XF United Kingdom  
Tel: +44 1933 402220 Fax: +44 1933 400724  
E-Mail: info@keb.co.uk Internet: www.keb.co.uk

**United States** | KEB America, Inc.  
5100 Valley Industrial Blvd. South  
Shakopee, MN 55379 United States  
Tel: +1 952 2241400 Fax: +1 952 2241499  
E-Mail: info@kebameric.com Internet: www.kebameric.com



## KEB PARTNERS WORLDWIDE

... [www.keb.de/contact/contact-worldwide](http://www.keb.de/contact/contact-worldwide)

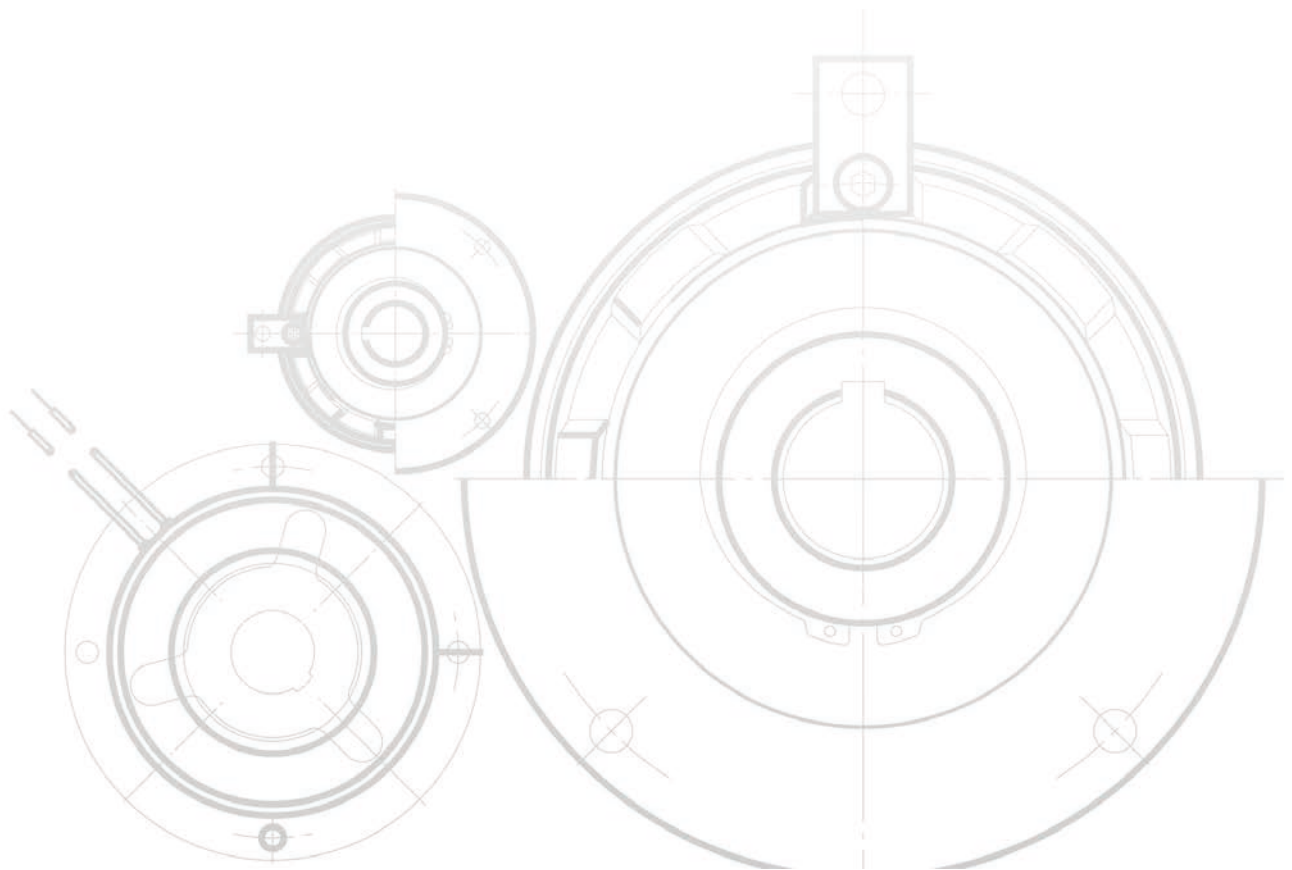

**Automation with Drive**

**[www.keb.de](http://www.keb.de)**

KEB Automation KG Suedstrasse 38 32683 Barntrup Germany Tel. +49 5263 401-0 E-Mail: [info@keb.de](mailto:info@keb.de)