

Linear actuator Econom 0

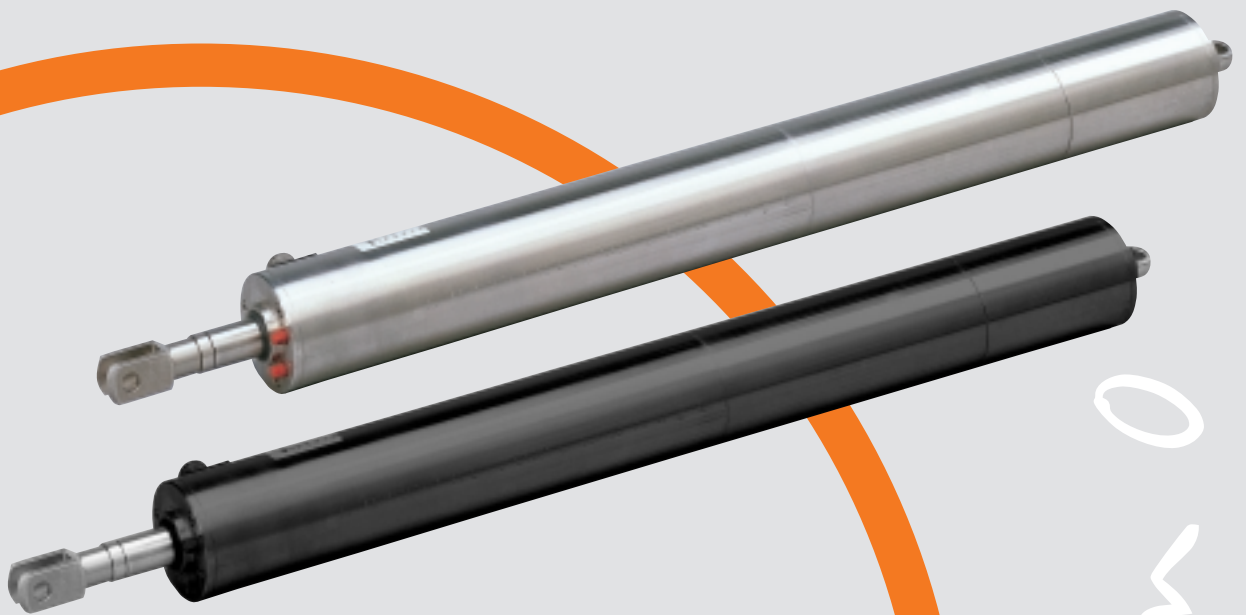

*Our intelligent model:
Econom 0*



Econom 0

Linear actuators Econom 0



Description · Applications · Facts

The users of the steel or stainless steel Econom 0 come from many different industries:

From architects and planners of contemporary façade architecture up to plant construction and mechanical engineering specialists.

One special Econom 0 model is UL certified and can be used without restrictions in the USA and Canada. You can find technical data about this model in a separate brochure.



Calculation example Econom 0 for dimension A

(based on the following requirements)

Pushing and pulling force	1400 N
Stroke	230 mm
Operating voltage	230 V 1 AC, rating: S3-15%
Fixing on piston end	fixed articulated lug
Fixing on housing end	standard articulated lug
Capacitor	external (standard wiring diagram WS 0500)
Option	potentiometer

Selected version:

Force	→ version E	1500 N
Dimension G	→ fixed articulated lug	32 mm
Dimension F	→ ver. E, stroke 50-300 mm, 230 V	356 mm (Please observe the additional marks *, **, 1)
Inst. stroke**	→ installed stroke length	250 mm
Dimension L	→ option, potentiometer	75 mm
Dimension E	→ standard articulated lug	19 mm
Dimension A min.		732 mm

* brake dimension (75 mm) included

** installed stroke length at 50 mm intervals

1) including 50 mm guide extension

Load (N) and stroke speeds (mm/s)

Version	Stroke speed mm/s	400 V-3 AC Rating: S3 – 15%		230 V-1 AC Rating: S3 – 15%		24 V DC Rating: S3 – 15%			24 V DC Rating: S1			Number of add. planetary gear stages	Available with brake only
		Load N	Nominal current A	Load N	Nominal current A	Stroke speed mm/s	Load N	Nominal current A	Stroke speed mm/s	Load N	Nominal current A		
A	70	220	0.35	220	0.8	60	100	2.5	–	–	–	–	x
B	40	480	0.35	480	0.8	35	150	2.5	–	–	–	–	x
C	35	500	0.35	500	0.8	25	120	2.5	–	–	–	–	x
D	20	1000	0.35	1000	0.8	20	400	2.5	–	–	–	–	x
E	10	1500	0.35	1500	0.8	9	500	2.5	10	250	1.3	1	x
F	5	3000	0.35	3000	0.8	5	1200	2.5	6.5	500	1.3	1	–
G	3	3000	0.35	3000	0.8	3	2000	2.5	4	850	1.3	1	–
H	2.5	3000	0.35	3000	0.8	2	2500	2.5	3	1000	1.3	2	–
I	1.5	3000	0.35	3000	0.8	1.5	3000	2.0	1.8	1500	1.3	2	–
J	1	3000	0.35	3000	0.8	–	–	–	1	3000	1.3	2	–
K	0.6	3000	0.35	3000	0.8	–	–	–	0.7	3000	1.3	2	–

Technical data and dimensions

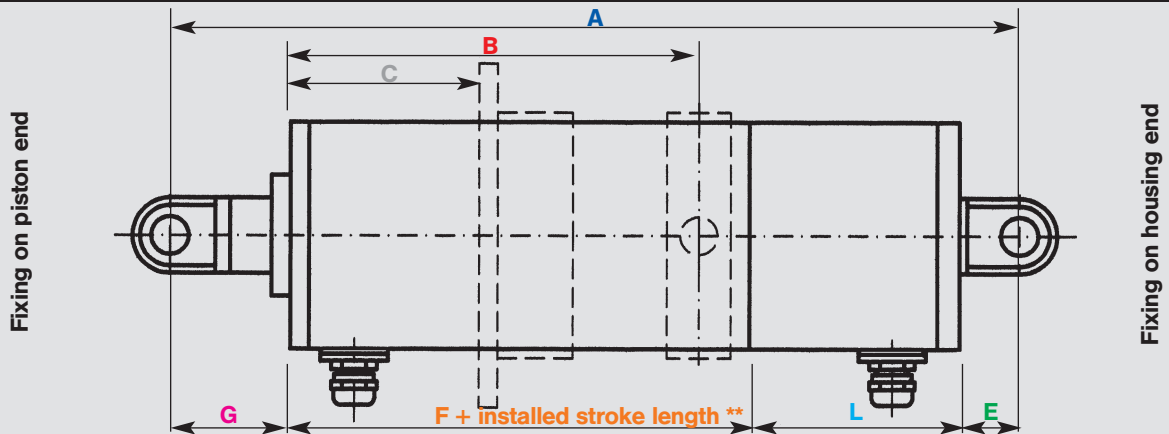

Dimension G Fixing on piston end

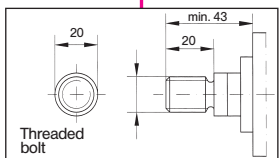
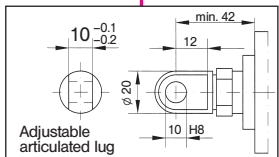
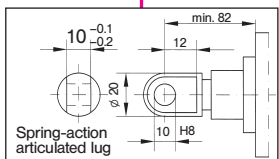
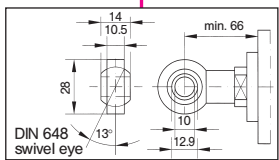
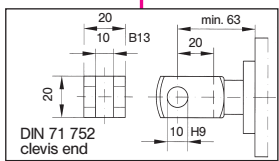
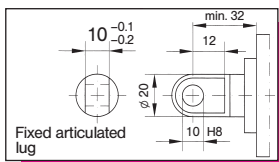

Dimension F

Version	Stroke lengths 50–300 mm		Stroke lengths 350 & 400 mm	
	24 V DC	230/400 V	24 V DC	230/400 V
A*	303	343	353 ¹⁾	393 ¹⁾
B*	303	343	353 ¹⁾	393 ¹⁾
C*	303	343	353 ¹⁾	393 ¹⁾
D*	303	343	353 ¹⁾	393 ¹⁾
E*	316	356	366 ¹⁾	406 ¹⁾
F	241	281	291 ¹⁾	331 ¹⁾
G	241	281	291 ¹⁾	331 ¹⁾
H	254	294	304 ¹⁾	344 ¹⁾
I	254	294	304 ¹⁾	344 ¹⁾
J	254	294	304 ¹⁾	344 ¹⁾
K	254	294	304 ¹⁾	344 ¹⁾

Dimension A Extension by addition of a protective sleeve

Extension	Max. utilised stroke
50 mm	0 mm - 200 mm
100 mm	> 200 mm

Dimension L Extension by addition of accessories

	24 V	230 / 400 V
Potentiometer	not available	+ 75 mm
Encoder	not available	+ 75 mm
Integrated capacitor	-	+ 97 mm
Force limiter	not available	not available

Limit switch adjustment screws

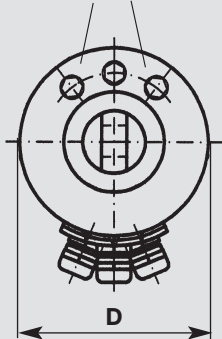

Dimension D

Ø 62 mm
(housing diameter)

Dimension B Pivot attachment

Dimension	
B	> 60 mm max. = stroke
V	68 mm
W	93 mm
X	10 mm
Y	Ø 10 mm
	- 0.03 - 0.05

Dimension E Fixing on housing end

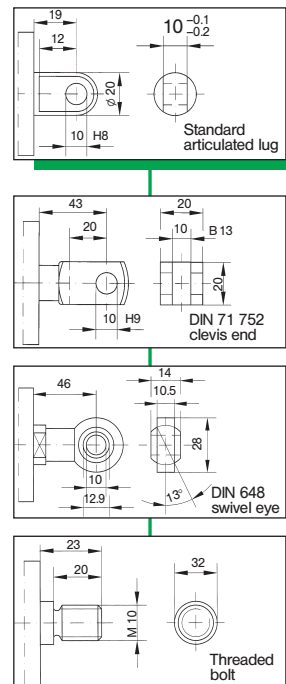

Dimension C Flange attachment

Dimension	
C	0 or > 60 mm max. = stroke
P	Ø 95 mm
Q	56 mm
R	Ø 5.5 mm
Flange thickness	5 mm

* brake dimension (75 mm) included ** installed stroke length at 50 mm intervals ¹⁾ including 50 mm guide extension

Options and wiring diagrams

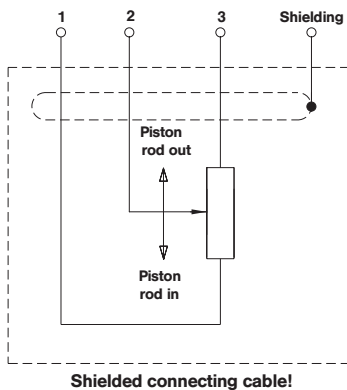

Terminal assignment:

Signal:	0 V	+U _B	A	\bar{A}	B	\bar{B}	0	$\bar{0}$
Core colour:	WH	BN	GN	YE	GY	PK	BU	RD
Without inversion:	WH	BN	GN		YE		GY	

Electrical characteristics:

Output circuit	Rail to rail	Signal level high	min. UB -2,5 V
Supply voltage	5...24 V DC	Signal level low	max. 0.5 V
Current consumption (without load)	max. 50 mA	Rise time (t)	max. 1 ms
Admissible load / channel	max. 50 mA	Fall time (t)	max. 1 ms
Impulse frequency	max. 160 kHz	Short-circuit proof outputs	yes

CE compliance according to EN 50081-2 and EN 55011 class B.

Wiring diagram – Potentiometer

Terminal assignment – Encoder

Standard wiring diagrams

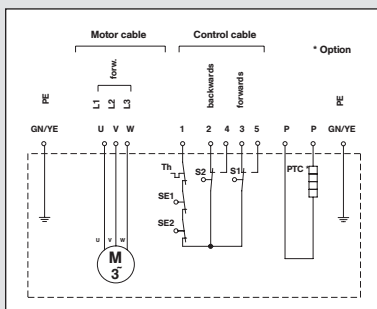

DS 0200 / 400 V 3AC

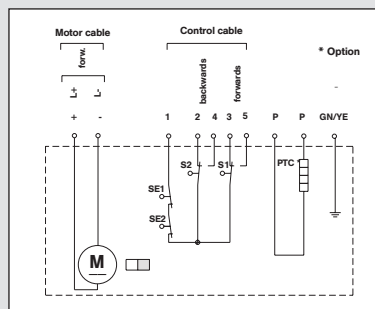

GS 0100 / 24 V DC

Th = Thermal protection contact
 SE = Safety limit switch
 S1 = Limit switch
 Piston rod out
 S2 = Limit switch
 Piston rod in
 PTC = Heating element

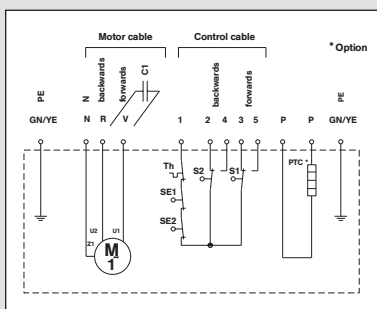

WS 0500 / 230 V 1AC

(especially for mechanical engineering)

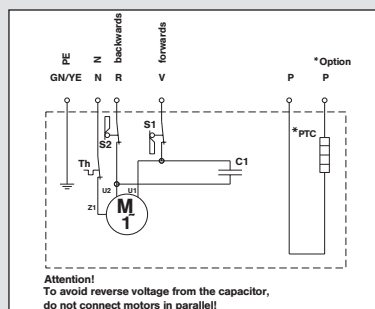

WS 0800 / 230 V 1AC

(especially for façade construction)

Options

(Please observe the availability notes in the table on page three)

- Standard potentiometers (1 kOhm, 5 kOhm, 10 kOhm, 100 kOhm)
- Precision potentiometers (1 kOhm, 5 kOhm, 10 kOhm)
- Encoders (especially 60 or 80 impulses per revolution)
- Internal capacitor
- Brake (supply voltages 24V DC, 230 V 1AC, 400V 1AC)
- Protective sleeve
- UL certified, stainless steel Econom 0 (technical data can be found in a separate brochure)