

E-Series Screw Jacks

Metric Machine Screw Jack

Stainless Steel Machine Screw Jack

Metric Ball Screw Jack



E-Series

1



BEST ENGINEERED
SOLUTION FOR
PRECISION LINEAR
ACTUATION,
POWER TRANSMISSION
& MECHANICAL JACKING.



DESIGN WITH POWER

Our expertise has been built on a history of engineering craftsmanship and design dating back to 1903. The facility in Scotland is the UK's largest screw jack manufacturing facility, that uses the latest engineering technologies to deliver quality products (BS EN ISO 9001:2008) that offer reliability, performance and economy.

Power Jacks is synonymous with screw jack technology and its development. We have been involved with screw jacks since the product was invented in the late 1930's and this gives us unparalleled experience in the design and manufacture of both standard and special designs.

Complimenting the screw jacks, the Power Jacks portfolio also includes the design and manufacture of spiral bevel gearboxes, electric linear actuators and planetary roller screws. This enables us to offer our customers a complete linear motion and power transmission system and solution.

We know our customers demand our engineering expertise to help find a solution for their applications. We take pride in designing and delivering the best solution.

This is what defines the Power Jacks range.







1. E-Series Screw Jack Overview

Building System - Rotating Screw Jack	6
Building System - Translating Screw Jack	7
Jacking Systems	8
Product Code	10
Selecting a Screw Jack	12

2. Metric Machine Screw Jack 16

Features	18
Application Focus.....	20
Performance	21
Translating Screw Jack Dimensions	22
Rotating Screw Jack Dimensions	24
Anti-Backlash Feature	25
Anti-Rotation (Keyed)	26
Secondary Guide	26
Safety Nuts.....	27
Double Clevis Screw Jacks	28
Flange Bolt for Worm Shafts	29

3. Stainless Steel Machine Screw Jack 30

Features	32
Application Focus.....	34
Performance	35

4. Metric Ball Screw Jack..... 36

Features	38
Application Focus.....	40
Performance	41
Translating Screw Jack Dimensions	42
Rotating Screw Jack Dimensions	44
Ball Nut Design	45
Flange Bolt for Worm Shafts	46
Double Clevis Ball Screw Jacks	46
Anti-Rotation.....	47

5. Special Designs..... 48

Roller Screw Jacks	50
Custom Features.....	51
Application Focus.....	52

6. Screw Jack Accessories 54

End Fittings.....	56
Machine Screw Jack Bellow Boots.....	58
Ball Screw Jack Bellows Boots	61
Limit Switches on Cover Pipe.....	64
Rotary Limit Switch - RLS	65
Rotary Limit Switch - SKA	66
Motor Adapter	67
Trunnion Mounts.....	68
Stop Nuts & Hand Wheels	69

7. Engineering Guide 70

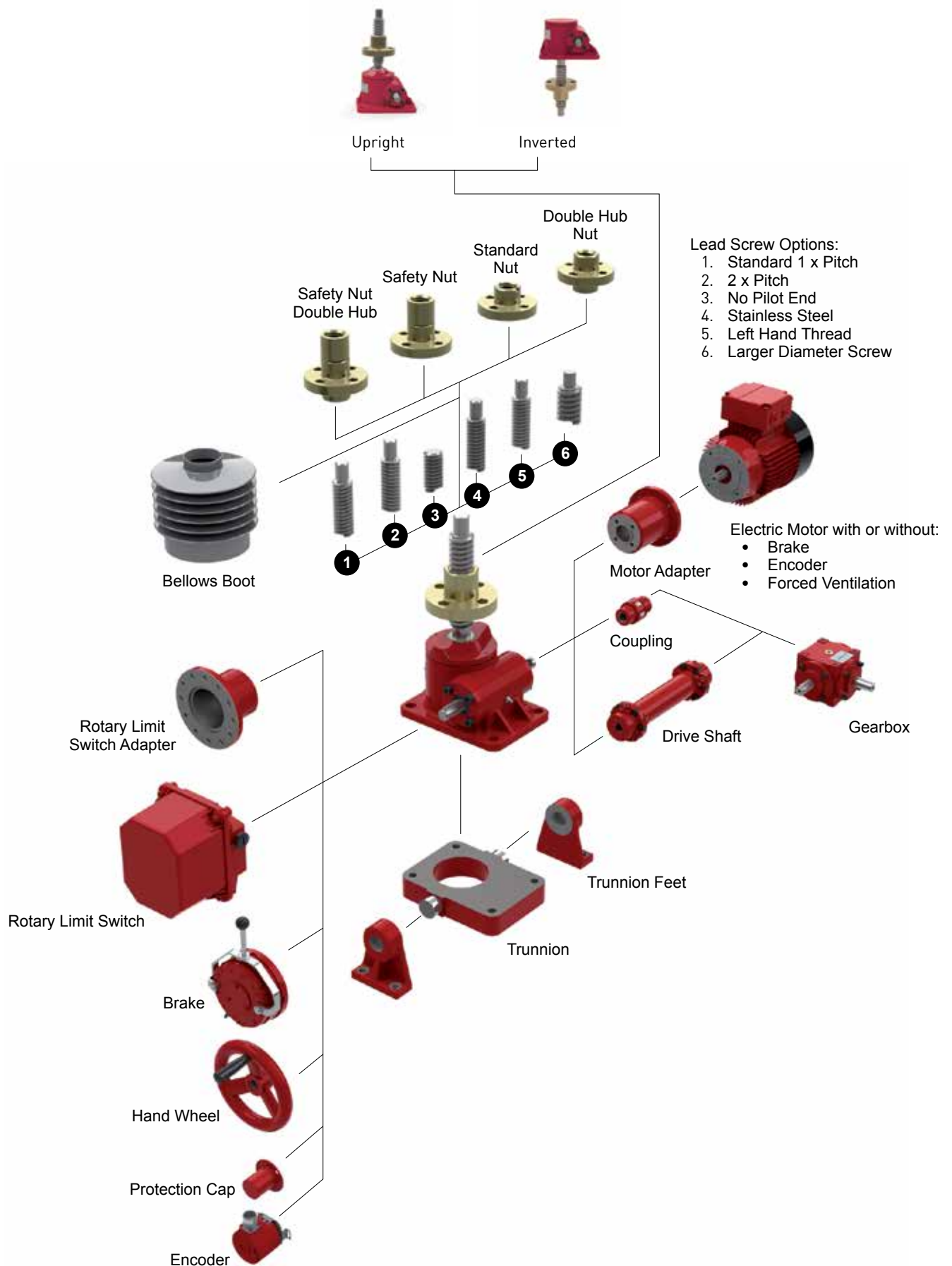

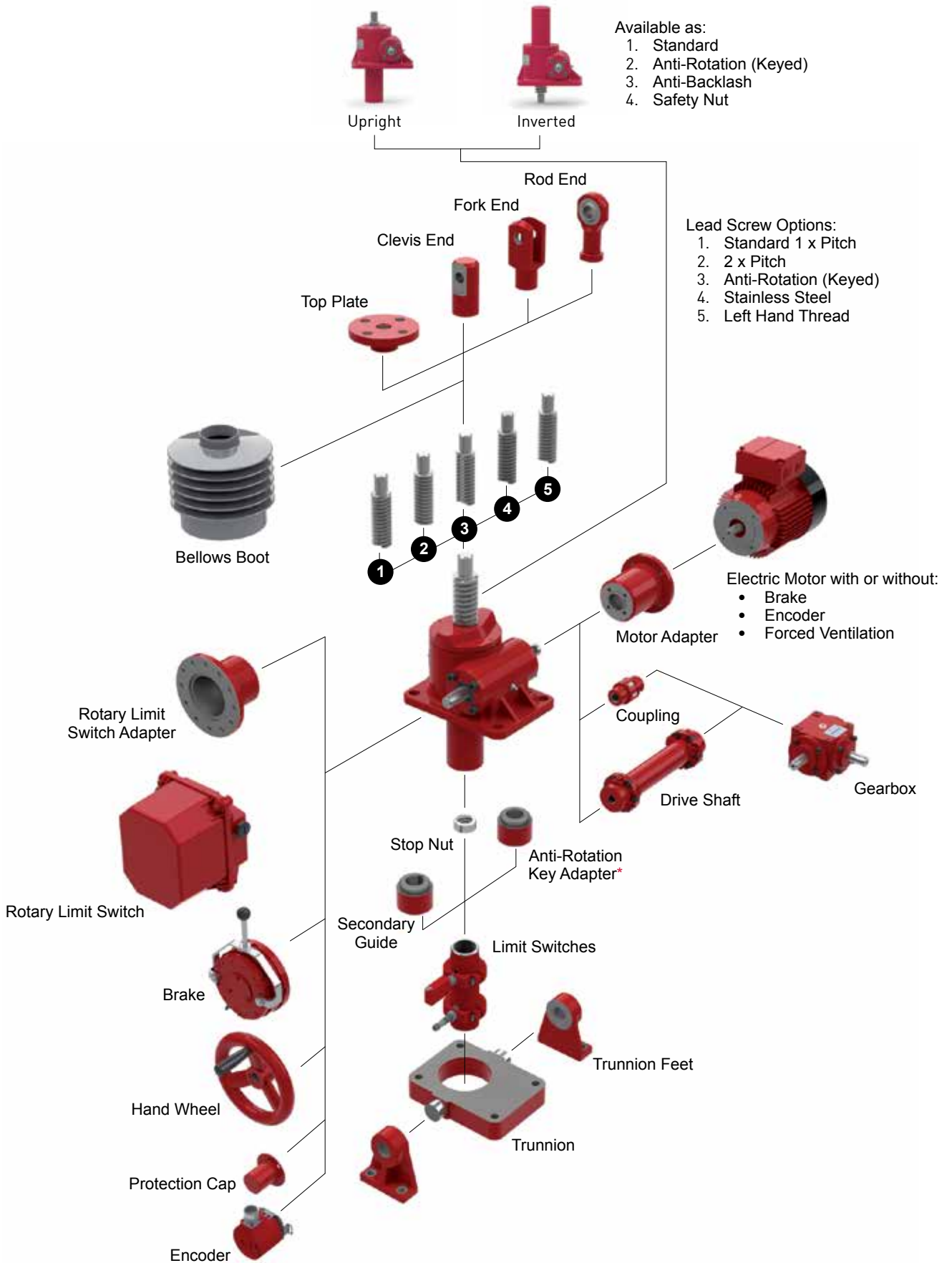

* For use with Anti-Backlash and some Safety Nut models only.

Screw jacks can be connected together in systems so that multiple units can be operated and controlled together. These jacking system arrangements or configurations can be built in many formats with the use of bevel gearboxes, motors, reduction gearboxes, drive shafts, couplings, plummer blocks and motion control devices.

Four of the most popular system configurations are the 'H', 'U', 'T' and 'I' configured jacking systems. Note that multiple screw jacks can be linked together mechanically or electrically. The latter is useful if there is no space for linking drive shafts.

Typical 'H' configuration System

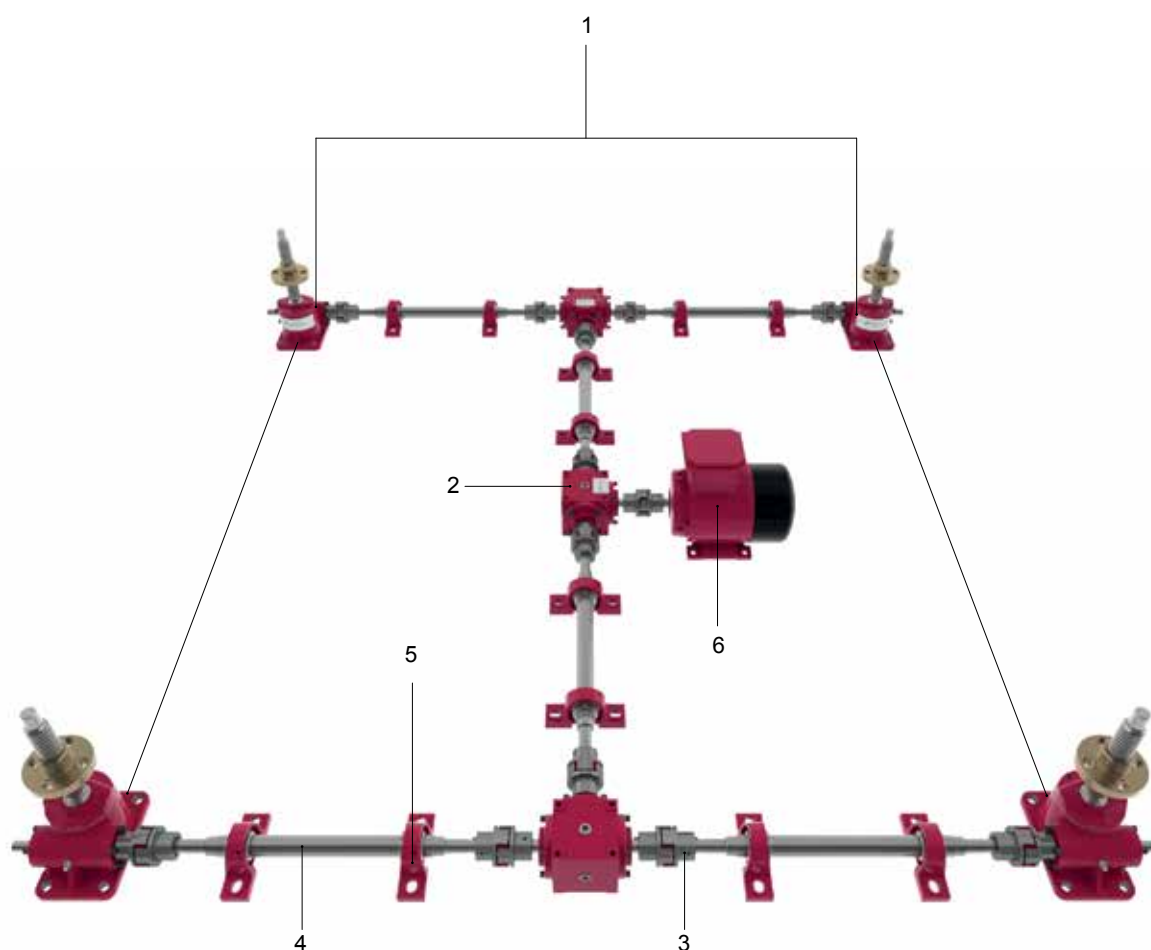

1. Screw Jack
E-Series
Upright Rotating Machine Screw Jack shown here.
2. Bevel Gearbox
Neeter drive Range-N
Refer to Range-N Bevel Gearbox catalogue for details.
3. Flexible Coupling
A range of couplings are available to suit each systems requirements including Jaw, Spacer and Geared types.
4. Drive Shaft
Every drive shaft is manufactured to order for each system design. Self supporting drive shafts (spacer couplings) are also available.
5. Shaft Supports (plummer blocks).
6. Electric Motor
Standard electric motors in 3phase, 1phase, DC and servo designs. Supplied as a basic motor or as part of a geared motor. Brakes are available for all motors.

Jacking systems are not limited to the number of screw jacks shown here. They are regularly supplied to clients with 2, 4, 6, 8 jack systems. Larger systems can extend up to 16 or higher. With the use of electronic synchronisation/control multiple systems or screw jacks can be used in unison. Extending the possible number of screw jacks used in unison in excess of 100.

To facilitate electronic control of screw jacks, feedback devices (eg encoder, limit switch) are available, mounted on the screw jack or its motor or another system component.

'U' Configuration System



'I' Configuration System



'T' Configuration System



1 E-Series - Screw Jack Overview

Example

KME1819-300-BR, 200 kN inverted keyed translating machine screw jack with top plate, 300 mm of stroke, bellows boots fitted to protect lifting screw and a single ended worm shaft extension on the right-hand side only.

K	M	E	1819	300	BR
↓	↓	↓	↓	↓	↓
(a)	(b)	(c)	(d)	(e)	(f)
↓	↓	↓	↓	↓	↓
Prefix	Feature	Series	Series No.	Travel of Unit (mm)	Suffix

Prefix (a)

- S - All Stainless Steel Screw Jack^{#2}
- K - Keyed Lifting Screw^{#3} (Anti Rotation)

Feature (b)

- T - Threaded End on Lifting Screw (standard)
- M - Top Plate on End of Lifting Screw
- C - Clevis End on Lifting Screw
- F - Fork End on Lifting Screw
- R - Rod End on Lifting Screw
- P - Plain End, with no Machining on End of Lifting Screw^{#1}
- U - Upright Rotating Screw Jack
- D - Inverted Rotating Screw Jack
- CC - Screw Jack with Double Clevis Mounting Arrangement

Series (c)

- E - E-Series Screw Jacks

Capacity and Series Designations (d)

Upright Translating Screw Jacks

Capacity (kN)	5	10	25	50	100	200	300	500	1000	1500	2000
Machine Screw Jack	2625	2501	1802	1805	1810	1820	1830	1850	18100	18150	18200
Ball Screw Jack	-	28501	3802	3805	3810	3820	3830	3850	38100	38150	38200

Inverted Translating Screw Jacks

Decrease the upright model number by 1.

Example

50kN Inverted Machine Screw Jack = 1804

200kN Inverted Ball Screw Jack = 3819

Rotating Screw Jacks

Increase the upright model number by 1.

Example

50kN Rotating Machine Screw Jack = 1806

200kN Rotating Ball Screw Jack = 3821

Anti-Backlash Screw Jacks

Replace the first digit in the model number with a 4.

Example

50 kN upright anti-backlash Screw Jack = 4805

Optional Lead (Ball Screw Jacks Only)

Metric Ball Screw Jacks have an increased lead screw option for the ball screw assembly (typically double). To specify the higher option add a "1" to the end of the model number.

Example

200kN Upright Ball Screw Jack with 20mm lead = E38201

Third Space Numerals (e)

The characters appearing in this space are to indicate stroke in millimetres on all standard units, but not on specials. This space on special screw jacks helps to identify to our Engineering Department the actual Screw Jack model produced. The numerals do not indicate stroke or type of modification performed on special orders.

Suffix (f)

- 1 - Gear ratio option-2 required
- B - Indicates bellows boot required to protect lifting screw
- G - Secondary guide for the lifting screw
- H - Stop Nut (Full Power) on Lifting Screw
- L - Single-end worm shaft extension on left-hand side only
- R - Single-end worm shaft extension on right-hand side only
- D - Safety Nut Load in Tension
- C - Safety Nut Load in Compression
- T - Trunnion
- X - Supplied without bottom pipe, but with guide bushing
- S - Special design features. More detail supplied separately. Only used at enquiry stage. Once ordered all special designs receive a unique part number.

Note

1. All suffixes (f) that do not conflict with another may be used in series against one Screw Jack
2. For E-Series Screw Jacks with plain ended lifting screws consult Power Jacks
3. For Stainless Steel Screw Jacks with varying materials and/or platings consult Power Jacks
4. For external keyed guides consult Power Jacks.

Five Step Guide to Initial Screw Jack Selection

The following selection procedure is applicable for Machine Screw and Ball Screw Jacks.

Calculate Power and Torque Requirements

Select a screw jack from the tables with adequate load carrying capacity and note the screw jack static and dynamic efficiency for required input speed.

Step 1 - Screw Jack Input Speed

$$N \text{ (rpm)} = \frac{\text{Linear Speed (mm/min)} \times \text{Gear Ratio}}{\text{Pitch (mm)} \times N^\circ \text{ of Starts on Lifting Screw}}$$

Input speed should not exceed 1800 rpm.
Number of starts on lifting screw is usually 1, unless otherwise stated.

Step 2 - Operating Input Power (kW), P_{in}

$$P_{in} \text{ (kW)} = \frac{\text{Load (kN)} \times \text{Linear Speed (mm/min)}}{60000 \times \eta_d}$$

η_d = Dynamic Screw Jack Efficiency

Step 3 - Operating Input Torque

$$T_{ino} \text{ (Nm)} = \frac{P_{in} \text{ (kW)} \times 9550}{N \text{ (rpm)}}$$

Step 4 - Screw Jack Start-Up Torque

$$T_{ins} = \frac{\text{Load (kN)} \times \text{Pitch (mm)} \times N^\circ \text{ of Starts on Lifting Screw}}{2 \times \pi \times \eta_s \times \text{Gear Ratio}}$$

η_s = Static Screw Jack Efficiency

Step 5 - Mechanical Power and Torque Check

Check whether the screw jack power and torque required for the application is not greater than the maximum allowable mechanical input power ($P_{mechanical}$) and Start-Up Torque at Full Load (T_s) values specified in the screw jack performance tables.

If $P_{mechanical} > P_{in}$ & $T_s > T_{ins}$ then the screw jack selected is acceptable for power requirements.

Example Selection

Application Constraints

- Load on Screw Jack = 15 kN in Tension
- Linear Speed required = 100 mm/min

Consider all application constraints then choose a screw jack that looks suitable for the application with a load rating equal to or greater than the maximum working load. For this example, a 25 kN E-Series Machine Screw Jack (refer P21) with translating screw, 6:1 gear ratio, single start lifting screw (6 mm lead).

Calculate Power and Torque Requirements

Step 1 - Screw Jack Input Speed

$$N \text{ (rpm)} = \frac{100 \text{ (mm/min)} \times 6 \text{ (Gear Ratio)}}{6 \text{ (mm)} \times 1 \text{ (N}^\circ \text{ of starts on Lifting Screw)}}$$

$$N = 100 \text{ rpm}$$

Input speed should not exceed 1800 rpm.

Step 2 - Operating Input Power (kW), P_{in}

$$P_{in} \text{ (kW)} = \frac{15 \text{ (kN)} \times 100 \text{ (mm/min)}}{60000 \times 0.264}$$

$$\eta_d = 0.264 \text{ (Refer P21)}$$

$$P_{in} = 0.095 \text{ kW}$$

Step 3 - Operating Input Torque

$$T_{ino} \text{ (Nm)} = \frac{0.095 \text{ (kW)} \times 9550}{100 \text{ (rpm)}}$$

$$T_{ino} = 9.1 \text{ Nm}$$

Step 4 - Screw Jack Start-Up Torque

$$T_{ins} = \frac{15 \text{ (kN)} \times 6 \text{ (mm)} \times 1 \text{ (N}^\circ \text{ of starts on Lifting Screw)}}{2 \times \pi \times 0.201 \times 6 \text{ (Gear Ratio)}}$$

$$T_{ins} = 11.9 \text{ Nm}$$

$$\eta_s = 0.201 \text{ (refer P21)}$$

Step 5 - Mechanical Power and Torque Check

Find the screw jacks mechanical power and torque rating from the performance data tables (refer P21).

$$P_{\text{mechanical}} = 1.5 \text{ kW} > P_{in} \text{ and } T_s = 19 \text{ Nm} > T_{ins}$$

Therefore the screw jack selected is suitable for application for initial constraints tested, further analysis may be required to ensure the screw jack is suitable for all application conditions. Continue with further selection calculations or consult Power Jacks Ltd.

Screw Jack Constraints for Detailed Selection

Lifting Screw Column Strength

For compressive loads on the screw jack lifting screw column strength calculations are required to check for buckling. As a screw jack selection guide use the following process:

1. Determine the maximum column strength (L) for the screw jack being considered (refer Engineering Guide P70).
2. Referring to the relevant column buckling chart (refer P72-75) determine the permissible compressive load (Wp) corresponding to the column length (L) for the appropriate end constraints. This permissible compressive load is the maximum load (inclusive of shock loads) which may be applied to the screw jack for a given column length.
3. Where an application involves human cargo or there is a risk to personnel, it is highly recommended that the permissible compressive load (as calculated above) be factored by 0.7 to enhance working safety. (Equivalent to a column strength safety factor of 5).

$$W_{phc} = W_p \times 0.7 \quad \text{(Permissible compressive load for personnel risk applications)}$$

- Note**
1. For detailed analysis of screw jacks and their systems consult Power Jacks.
 2. Safety factor of 3.5 for column strength's used for normal industrial cargo.

Lifting Screw Critical Speed

For fast operating rotating screw jacks, the critical speed (rotational speed) of the lifting screw needs to be considered in case of shaft whirling. To calculate the critical speed for rotating screw jacks:

1. Refer to the appropriate critical speed chart in the Engineering Guide on P76.
2. Select the correction factor F_{cs} corresponding to the end support conditions for the application.
3. From the critical speed chart, select the critical speed corresponding to the unsupported screw length (m) and the screw jack load rating (kN).
4. Calculate the limiting critical speed with the formula: **Limiting Critical Speed = Critical screw speed x F_{cs}**

Lifting Screw Deflection

The lifting screw of a screw jack mounted horizontally will deflect under its own weight to some extent. The amount of deflection tolerable (y_T) should be less than 0.5 mm per metre.

Deflection Factors, F_{sd}

Fixed/Fixed. $F_{sd} = 8$

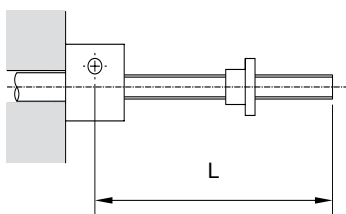

Fixed/Fixed. $F_{sd} = 186$

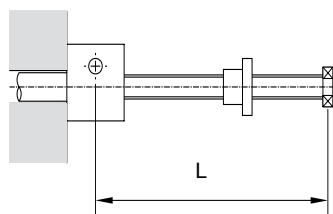

Fixed/Fixed. $F_{sd} = 384$

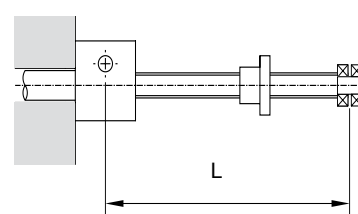

$$\text{Deflection, } y, \text{ (mm)} = \frac{6 \times 10^{-9} \times L^4}{F_{sd} (d-p)^2}$$

$$\text{Deflection Tolerable, } y_T, \text{ (mm)} = \frac{0.5 \times L}{1000}$$

L = Lifting Screw Length (mm)
d = Diameter of Lifting Screw (mm)
p = Pitch of Lifting Screw (mm)

If $y < y_T$ then the lifting screw deflection is acceptable.

Note: This is only a deflection guide. For detailed analysis, including methods to reduce deflections, consult Power Jacks Ltd.

Screw Jack Input Torque

Start up/static torque values are listed in all performance tables. Whereas dynamic torque values are either calculated using the tabulated dynamic efficiencies or taken direct from torque tables where listed. For detailed screw jack analysis consult Power Jacks Ltd.

Side Loads on Screw Jacks

It is recommended that all side loads (F_{sl}) are carried by guides in your arrangement and not by the lifting screw and nut. If there are any side loads on the screw jack, they must not exceed those tabulated in the Engineering Guide, Side Load Rating Section P78, and it must be noted that any such loads will adversely affect the life of the lifting screw and nut.

Radial Forces on Screw Jack Worm Shaft

For applications where a screw jack is belt driven, radial force (F_R) values exerted on the worm shaft must not exceed those tabulated in the Engineering Guide Section P79. Values are tabulated for the metric machine screw jacks and ball screw jacks. The values are maximum values for the screw jacks at rated load regardless of worm speed or load direction.

Screw Jack Self-Locking

Approximately 50% of machine screw jacks are self-locking (Refer P83) either in the gearbox or the lifting screw, however to ensure there is no self-lowering and to reduce drift due to the motor slowing, a brake is recommended. Standard motor frame size brakes will be suitable for most applications with only slight vibration (Refer P86) and thermal fluctuation present. Motor selection as normal. For dynamic braking consult Power Jacks.

Ball screw jacks always require a brake as their high efficiency makes them self-lowering.

Use the closest standard brake size that is greater or equal to the motor brake torque required.

- Note**
1. Self lowering can occur in any jacking system not fitted with a brake, where high levels of vibration are present in the application.
 2. Power Jacks recommend the use of a brake on single screw jack applications in the vertical position.

Jacking System Power Input

Total Input Power for Jacking Systems (kW), P_s :

$$P_s = \frac{\text{Input Power per Screw Jack (kW)} \times \text{Number of Screw jacks}}{\text{Arrangement Efficiency} \times \text{Gearbox Efficiency}}$$

Number of Screw Jacks in System	2	3	4	6-8
Jacking System Efficiency	0.95	0.90	0.85	0.80

Gearbox Efficiency = Bevel Gearbox Efficiency x Reduction Gearbox Efficiency

Bevel Gearbox Efficiency = 0.95 typical

Reduction Gearbox Efficiency = Consult unit details, if no reduction gearbox present assume efficiency of 1.

Note

For Screw Jacks connected in-line, the worm shaft can transmit up to 3 times the torque for a single screw jack at its maximum capacity, except the E1820 (200kN) Unit which can transmit 1.5 times the torque (refer P86).

Metric Machine Screw Jack

AVAILABLE IN MANY
STANDARD MODELS
WITH A WIDE RANGE OF
CAPABILITIES, THERE IS
A STANDARD MODEL FOR
ALMOST ANY REQUIREMENT.



Key Features

- Standard Performance Power Jack
- Metric Single Face Machine Screw Jacks
- Capacities - 5kN to 2000 kN as standard
- Translating and Rotating Screw in Upright and Inverted types
- Precision Worm Gear Set
- 2 Gear ratios and 1 screw lead as standard
- Anti-backlash and anti-rotation (keyed) options
- 6 mounting options including trunnion and double clevis
- Special custom designs available

End Fittings as Standard

- 1. Top Plate (shown)
- 2. Clevis End
- 3. Fork End
- 4. Rod End

Bellows Boot Screw Protection
Prevents ingress of dirt and debris onto screw threads.

Shell Cap
Locked in place by set screws.

Load Bearings
Bearings, top and bottom to take loads in tension or compression.

Worm Shaft
Available in standard, plated or stainless steel.

Housing
Aluminium on 5 & 10 kN models, ductile iron on 25 kN through 100 kN models, cast steel on 200 kN through 2000 kN models.

Cover Pipe
Protects lifting screw threads.

Threaded end on screw as standard. End fittings screw on.

Precision Machined Lead Screw available in standard material or stainless steel.

Accurately hobbled aluminium bronze worm gear for greater gear contact.

Thrust Bearings and Grease Seals
At each end of worm. 5 & 10 kN models do not have separate seals.

Mounting Bolt Holes

Integrated Lubrication Systems

Grease Application Point

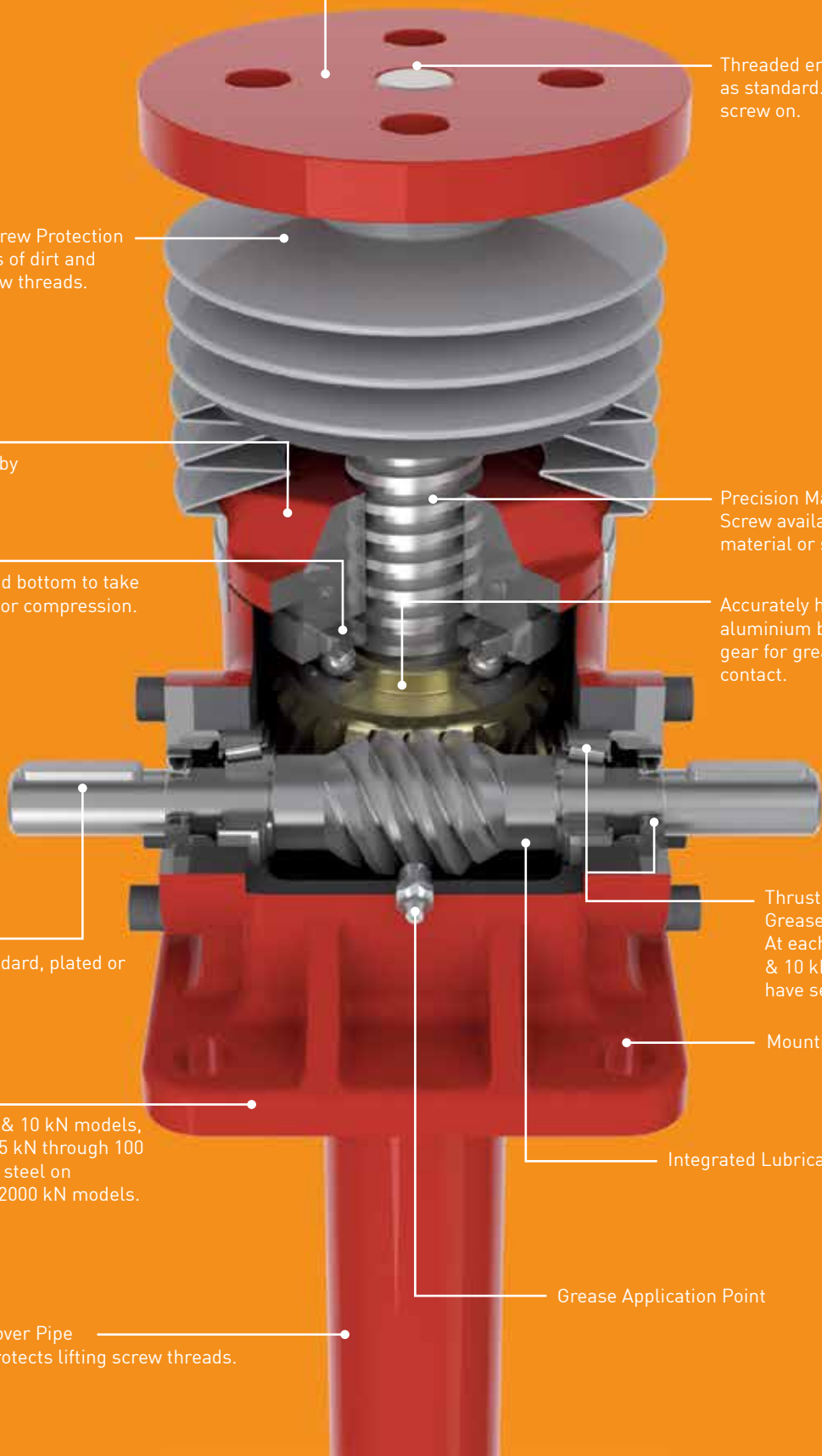

Translating Screw

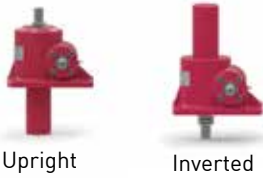

Upright

Inverted

Rotating Screw



Upright

Inverted

Typical Applications

Conventional Machine Screw Jacks are most widely used for intermittent duty cycles, as the screw jack incorporates a precision worm gear set in a rugged casting delivering positive, precise actuation. Available in a comprehensive range of materials and fittings with the option for special designs for specific application requirements.

Selecting the Right Screw Jack

Consider all application constraints then choose a product that looks suitable for the intended application. Calculate the power and torque requirements. This is a 5 step process:

- Screw Jack Input Speed (RPM)
- Operating Input Power (kW)
- Operating Input Torque (Nm)
- Screw Jack Start-up Torque (Nm)
- Mechanical Power and Torque Check

Special Designs

1. Modifications to the standard screw jacks

This would include non-standard painting or plating of the housing, 2 or 3 start threaded lifting screws, stainless steel lifting screws or worm shafts, increased closed heights, extended worm shafts, opposite threading of lifting screws, etc.

2. Additions to the standard screw jacks

Items such as wear indicators, safety nuts, rotation monitoring kits, special lifting screw end fittings, encoder adapter flanges, etc.

3. Completely special screw jacks

Where a modification of our existing range is not practical we have the facilities to design and manufacture screw jacks tailored specifically to your requirements.

Systems

The screw jacks can be connected together in systems so that multiple units can be operated and controlled together. These jacking system arrangements or configurations can be built in many formats with the use of bevel gearboxes, motors, reduction gearbox, drive shafts, couplings, plummer blocks and motion control devices.

The use of bevel gearboxes allows the distribution of drive throughout a jacking system. The gearboxes come in 2,3 and 4 way drive types. See Neeter Drive Bevel Gearboxes brochure for more details.

Bevel gearboxes and other system components can also be supplied in stainless steel or other corrosion resistant designs.

Two of the most popular system configurations are the 'H' and 'U' configured jacking systems. Remember that multiple screw jacks can be linked together mechanically or electrically. The latter is useful if there is no space for linking drive shafts.



If multiple machine screw jacks are connected in a mechanically linked system then the complete system may be considered self-locking. If you would like this checked consult Power Jacks. Alternatively, to be sure, include a brake on the system either as a stand alone device or as a brake motor.

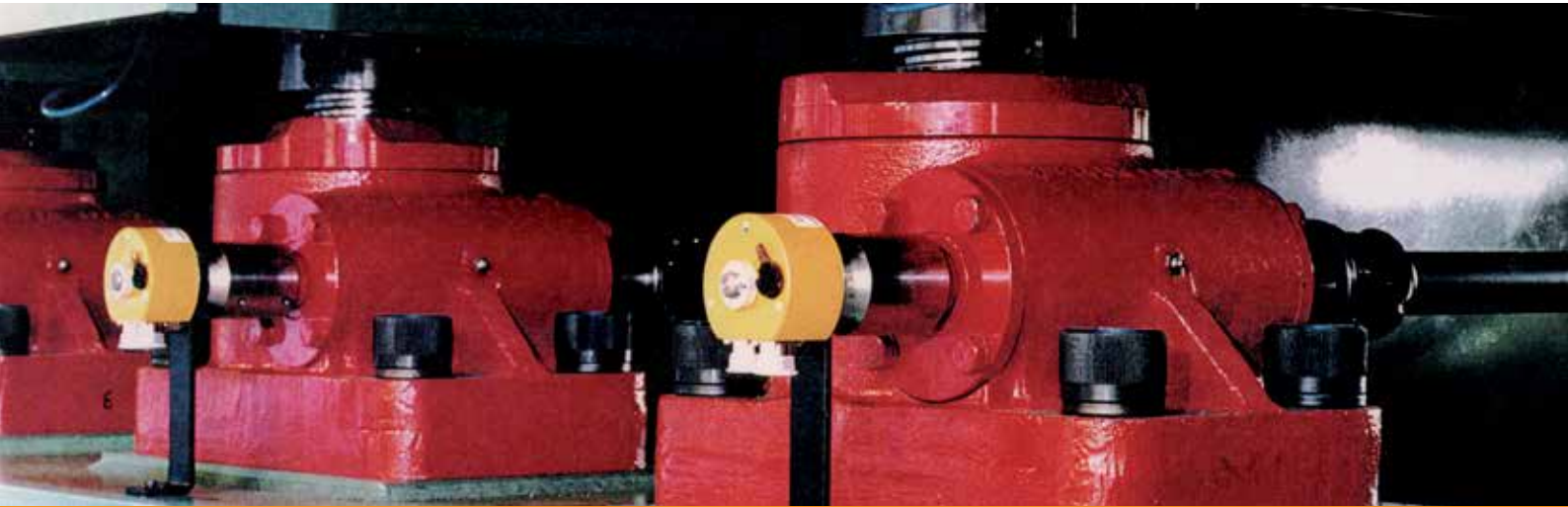

BRONX METAL SECTION STRAIGHTENER

Variable centre straighteners for moving the centre straightening rollers, end pinch rollers and the landing legs.

A jacking system for each straightening roller has two special design screw jacks and a strengthened gearbox, rated for a 700kN dynamic capacity in compression. The pinch rollers have their position adjusted by two horizontally opposing screw jacks, driven individually by motorised helical gearboxes.

For more application examples see the 'Power at Work' brochure or www.powerjacks.com.



Standard Performance

Model		E2625	E2501	E1802	E1805	E1810	E1820	E1830	E1850	E18100	E18150	E18200
Capacity	kN	5	10	25	50	100	200	300	500	1000	1500	2000
Lifting Screw ^{note1}	mm	16 x 3	20 x 5	30 x 6	40 x 9	55 x 12	65 x 12	95 x 16	120 x 16	160 x 20	Available on Request	Available on Request
Gear Ratios	Option 1	5:1	5:1	6:1	6:1	8:1	8:1	10 2/3:1	10 2/3:1	12:1		
	Option 2	20:1	20:1	24:1	24:1	24:1	24:1	32:1	32:1	36:1		
Turn of worm for travel of lifting screw	Option 1	5 for 3mm	1 for 1mm	1 for 1mm	1 for 1.5mm	1 for 1.5mm	1 for 1.5mm	1 for 1.5mm	1 for 1.5mm	3 for 5mm		
	Option 2	20 for 3mm	4 for 1mm	4 for 1mm	4 for 1.5mm	2 for 1mm	2 for 1mm	2 for 1mm	2 for 1mm	9 for 5mm		
Max. Input Power (kW)	Option 1	0.25	0.375	1.5	3	3.75	3.75	6	11.25	18.5		
	Option 2	0.12	0.19	0.375	0.55	1.125	1.125	1.9	4.5	8.25		
Start up torque at full load (Nm) ^{note2}	Option 1	2.5	6.8	19.8	56	115.9	263.8	480	904	2025		
	Option 2	1.1	3	8.7	25.5	60.5	137	284	504	1119		
Weight (kg) - stroke = 150mm		1.03	2.27	8.17	15.88	24.72	45	86	195	553		
Weight (kg) per extra 25mm		0.073	0.13	0.21	0.32	0.57	0.86	1.58	2.49	4.31		
Option 1	Gear Ratio	5	5	6	6	8	8	10 2/3	10 2/3	12		
	Screw Jack Static Efficiency	0.189	0.233	0.201	0.213	0.206	0.181	0.149	0.132	0.131		
	Screw Jack Dynamic Efficiency	0.252	0.306	0.264	0.281	0.272	0.242	0.205	0.181	0.178		
Option 2	Gear Ratio	20	20	24	24	24	24	32	32	36		
	Screw Jack Static Efficiency	0.107	0.130	0.115	0.117	0.132	0.116	0.084	0.079	0.079		
	Screw Jack Dynamic Efficiency	0.160	0.194	0.167	0.172	0.190	0.169	0.128	0.120	0.123		

Notes

1. All metric machine screws have a trapezoidal thread form, single start as standard (diameter x pitch)
2. For loads of 25% to 100% of screw jack capacity, torque requirements are approximately proportional to the load
3. Efficiency values for standard grease lubricated worm gear box and lifting screw
4. All E-Series screw jacks have grease lubricated gearbox and lead screw as standard
5. For performance data for Anti-Backlash, Anti-Rotation (Keyed) and other variants, see p25.

Plan View

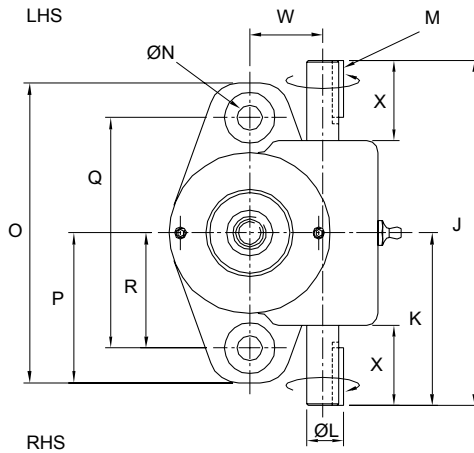

Models:
2625
2501

Plan View

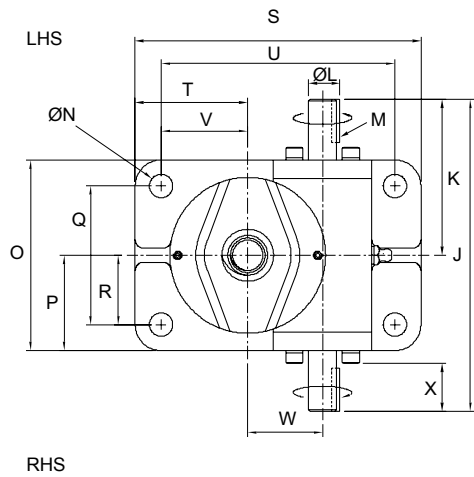

Models:
1802
1805
1810
1820
1830
1850

Plan View

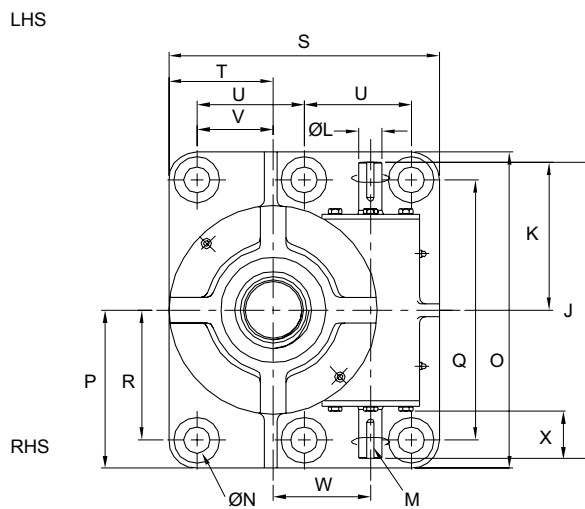

Models:
18100
18150
18200

Note

1. Closed Height of threaded end and top plate units is the same for upright or inverted models
2. LHS = Left Hand Side
3. RHS = Right Hand Side.

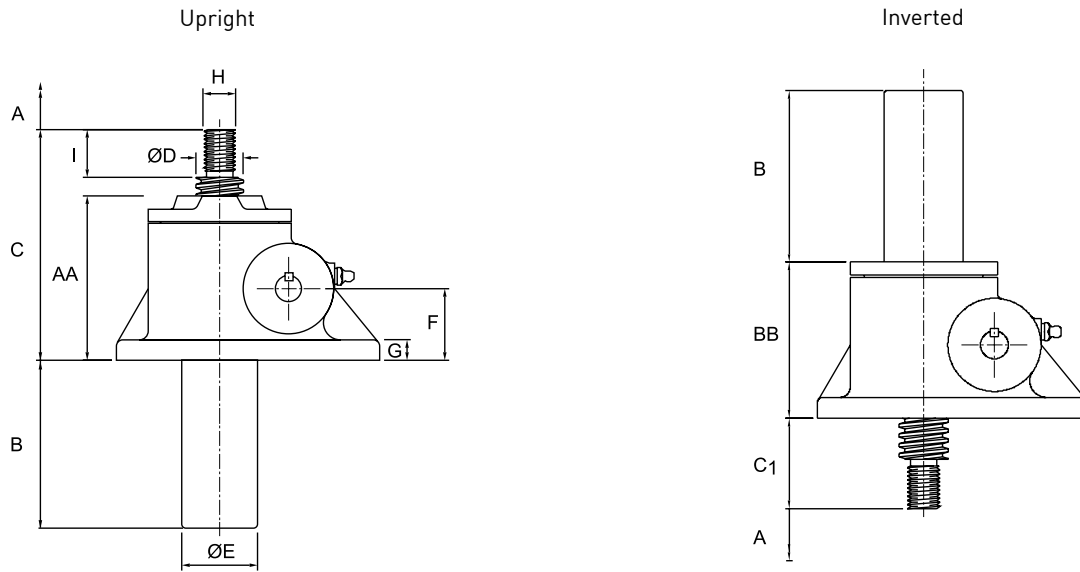

Model	Upright	E2625	E2501	E1802	E1805	E1810	E1820	E1830	E1850	E18100	E18150	E18200
	Inverted	E2624	E2500	E1801	E1804	E1809	E1819	E1829	E1849	E18099	E18149	E18199
Capacity [kN]		5	10	25	50	100	200	300	500	1000		
A		Stroke as required										
B		A + 9	A + 10	A + 5	A - 5	A + 3	A - 1	A + 15	A + 13	A + 3		
C		95	125	145	185	200	265	325	390	560		
C1		40	45	55	65	80	95	115	150	260		
ØD		16	20	30	40	55	65	95	120	160		
ØE		26.7	33.4	48.3	60.3	73	89	115	141	194		
F		26 ± 0.13	40 ± 0.13	45 ± 0.13	60 ± 0.13	60 ± 0.13	85 ± 0.13	105 ± 0.13	120 ± 0.13	150 ± 0.13		
G		10	10	13	14	16	20	30	32	40		
H		M10 x 1.5	M12 x 1.75	M20 x 2.5	M24 x 3	M36 x 4	M48 x 5	M72 x 4	M100 x 4	M125 x 4		
I		20	24	30	35	40	55	65	90	125		
J		120	150	180	230	280	300	380	460	580		
K		60	75	90	115	140	150	190	230	290		
ØL		10 h8	14 h8	16 h8	19 h8	25 h8	28 h8	35 h8	40 h8	45 h8		
M		3 x 3 x 18	5 x 5 x 25	5 x 5 x 25	6 x 6 x 32	8 x 7 x 40	8 x 7 x 40	10 x 8 x 50	12 x 8 x 56	14 x 9 x 70		
ØN		9	11	13.5	18	22	26	39	51	51		
O		110	130	110	150	190	210	260	300	620		
P		55	65	55	75	95	105	130	150	310		
Q		85	100	80	115	145	150	190	200	510		
R		42.5	50	40	57.5	72.5	75	95	100	255		
S		-	-	165	205	225	275	365	535	530		
T		-	-	65	75	75	105	140	225	205		
U		-	-	135	170	180	215	295	435	210		
V		-	-	50	57.5	52.5	75	105	175	150		
W		23.82 + 0.076 - 0.000	31.75 + 0.076 - 0.000	43.26 + 0.025 - 0.025	55.58 + 0.050 - 0.000	66 + 0.060 - 0.000	66 + 0.070 - 0.000	95.25 + 0.130 - 0.000	135 + 0.070 - 0.000	190.5 + 0.076 - 0.000		
X		27	35	27.5	35	44	44	56	66	88		
AA		64	90	103.5	138	146.5	195	235	275	405		
BB		64	78	95.5	122	130.5	179	235	275	405		

Available on Request

Available on Request

Note

1. All dimensions in mm
2. Closed height of threaded end and top plate units are the same for upright or inverted models
3. Rotating screw jacks (refer p24) have the same dimensions for the shell as the translating screw type.

For other dimensions and performance data refer to metric translating screw jacks. All dimensions in mm.

Upright

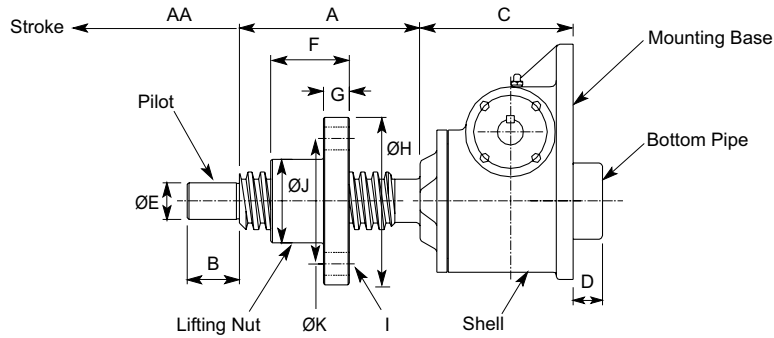

Model	UE2626	UE2502	UE1803	UE1806	UE1811	UE1821	UE1831	UE1851	UE18101	UE18151	UE18201
Capacity (kN)	5	10	25	50	100	200	300	500	1000	1500	2000
A	AA + 40	AA + 44	AA + 60	AA + 80	AA + 100	AA + 100	AA + 180	AA + 200	AA + 250	Available on Request	Available on Request
B	16	16	25	30	50	65	85	100	125		
C	64	90	103.5	138	146.5	195	235	275	405		
D	34	0	0	0	28	24	40	63	128		
ØE	10	12	20	25	35	45	75	90	125		
F	25	35	40	65	75	75	140	150	175		
G	10	12	15	20	25	25	35	50	60		
ØH	60	80	90	115	160	185	230	280	380		
I	4 x Ø9	4 x Ø11	4 x Ø13.5	4 x Ø18	4 x Ø22	4 x Ø26	6 x Ø26	6 x Ø33	6 x Ø45		
ØJ	25	35	40	55	80	90	125	160	210		
ØK (PCD)	42	57	65	85	120	135	175	220	295		

Inverted

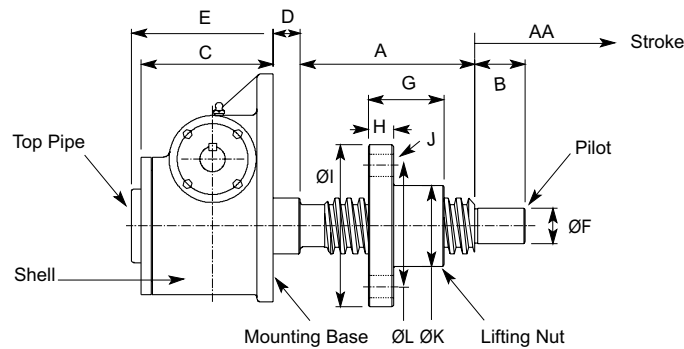

Model	DE2626	DE2502	DE1803	DE1806	DE1811	DE1821	DE1831	DE1851	DE18101	DE18151	DE18201
Capacity (kN)	5	10	25	50	100	200	300	500	1000	1500	2000
A	AA + 40	AA + 44	AA + 60	AA + 80	AA + 100	AA + 100	AA + 180	AA + 200	AA + 250	Available on Request	Available on Request
B	16	16	25	30	50	65	85	100	125		
C	64	90	95.5	122	130.5	179	235	275	405		
D	12	10	14	18	26.5	25	25	35	105		
E	64	90	95.5	122	130.5	203	275	313	458		
ØF	10	12	20	25	35	45	75	90	125		
G	25	35	40	65	75	75	140	150	175		
H	10	12	15	20	25	25	35	50	60		
ØI	60	80	90	115	160	185	230	280	380		
J	4 x 9	4 x 11	4 x 13.5	4 x 18	4 x 22	4 x 26	6 x 26	6 x 33	6 x 45		
ØK	25	35	40	55	80	90	125	160	210		
ØL (PCD)	42	57	65	85	120	135	175	220	295		

PCD = Pitch Circle Diameter

E-Series Metric Screw Jacks are available with anti-backlash nuts for applications where a reversal of loading from tension to compression is encountered and axial backlash is to be minimised.

Anti-Backlash Features

- Reduction in the axial backlash between the screw and the worm gear nut to a practical minimum for smoother, more precise operation and minimum wear
- Acts as a safety device, providing a dual nut load carrying unit, when the worm gear becomes worn
- Wear indicator for critical applications.

The anti-backlash feature can be maintained by adjusting the shell cap until the desired amount of backlash is achieved. To avoid binding and excessive wear, do not adjust lifting screw backlash to less than 0.025 mm.

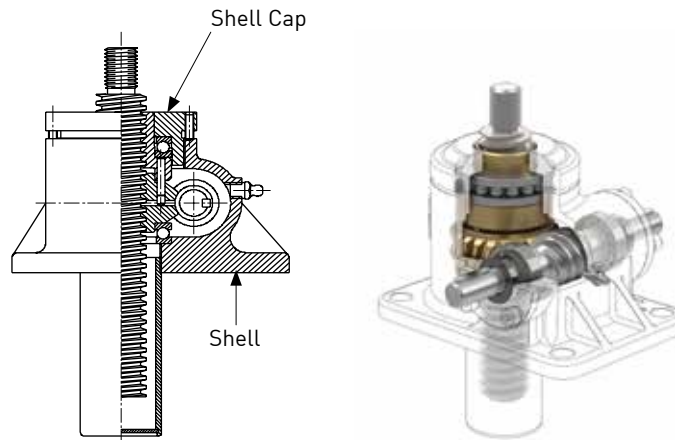

Anti-Backlash

Keyed Anti-Backlash (with Anti-Rotation)

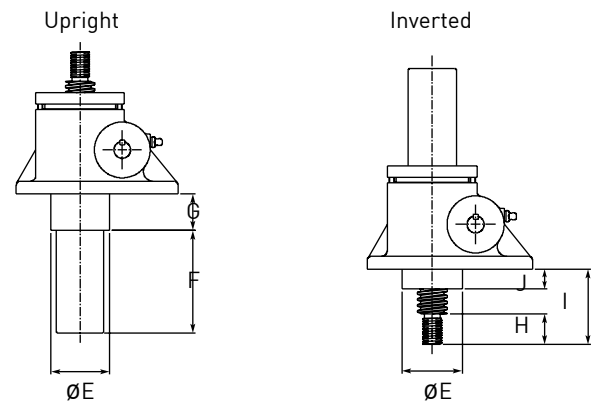
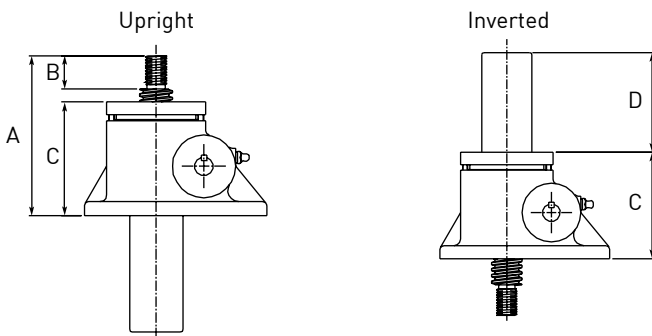

Note: Inverted unit closed height same as standard unit

Standard Dimensions (mm)

Anti-Backlash				Keyed Anti-Backlash (with Anti-Rotation)							
Model	A	B	C	D	Model	E	F	G	H	I	J
E4625	95	20	65	Stroke + 34	KE4625	36	Stroke + 9	25	20	40	14
E4501	125	24	86	Stroke + 35	KE4501	38	Stroke + 9	30	24	45	16
E4802	145	30	103.5	Stroke + 30	KE4802	60	Stroke +30	37	30	55	19.5
E4805	185	35	138	Stroke - 5	KE4805	75	Stroke + 20	40	35	65	24
E4810	200	40	146.5	Stroke +3	KE4810	90	Stroke + 3	48	40	80	30
E4820	265	55	195	Stroke +24	KE4820	102	Stroke + 24	58	55	110	39
E4830	340	65	250	Stroke + 38	KE4830	138	Stroke + 15	73	65	115	43
E4850	415	90	295	Stroke + 55	KE4850	206	Stroke + 13	95	90	213	63
E48100	585	125	415	Stroke + 35	KE48100	264	Stroke + 3	180	125	405	145

Torque and Efficiencies for Standard Anti-Backlash Screw Jacks

Model	Upright	E4625	E4501	E4802	E4805	E4810	E4820	E4830	E4850	E48100
	Inverted	E4624	E4500	E4801	E4804	E4809	E4819	E4829	E4849	E48099
Capacity (kN)		5	10	25	50	100	200	300	500	1000
Start-up torque at full load (Nm)	Standard	2.9	7.8	23.5	62	129	281	535	1003	2248
	Optional	1.3	3.7	9.8	28	67	153	314	568	1245
Screw Jack Static Efficiency	Standard	0.164	0.203	0.169	0.192	0.185	0.170	0.134	0.119	0.118
	Optional	0.090	0.109	0.102	0.105	0.119	0.104	0.076	0.070	0.071
Weight with Base Raise of 150mm (kg) approx.		1.48	2.72	8.62	16.78	26.12	48.6	90.5	208.6	609.8

Note: For loads from 25% to 100% of screw jack capacity, torque requirements are proportional to the load.

A keyed translating screw jack stops the screw from rotating without the need for end pinning. However the key-way in the screw will cause greater than normal wear on the internal threads of the worm gear.

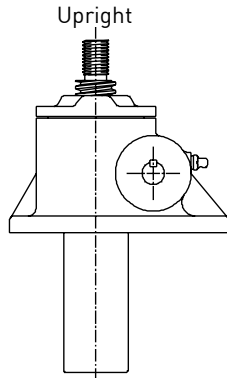

(dimensions as non-keyed version. P22-23)

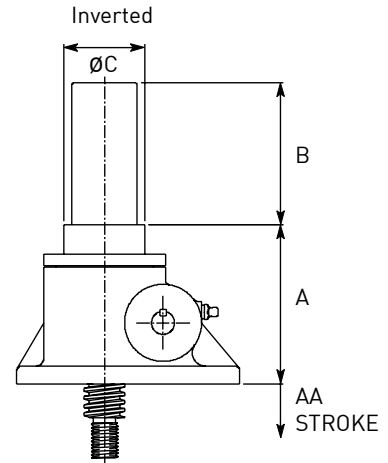

Standard Keyed Dimensions for Inverted Models

Model	E2624	E2500	E1801	E1804	E1809	E1819	E1829	E1849	E1899	
Inverted	A	79	78	125.5	159	167.5	210	267	**	**
	B	AA + 9	AA + 35	AA + 30	AA + 20	AA + 3	AA - 1	AA + 15	**	**
	$\varnothing C$	35	N/A	60	75	90	102	141.5	**	**

Secondary Guide

Secondary Guiding for the screw for greater lateral rigidity aiding screw guidance and improved side load resilience.

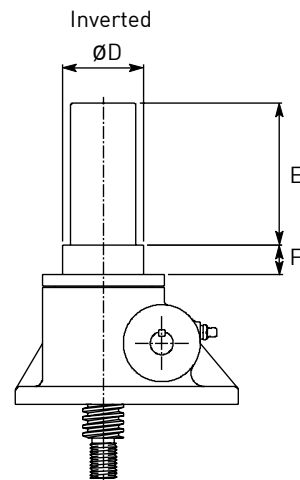
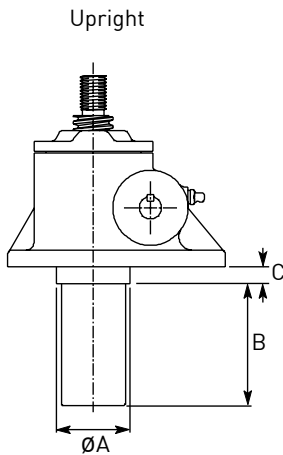

Standard Secondary Guide Dimensions

Model Capacity [kN]	E2625	E2501	E1802	E1805	E1810	E1820	E1830	E1850	E18100	
Upright	$\varnothing A$	36	38	60	70	90	100	138	155	225
	B	Stroke + 34	Stroke + 34	Stroke + 30	Stroke + 20	Stroke + 29	Stroke + 24	Stroke + 40	Stroke + 38	Stroke + 50
	C	16	20	20	18	20	20	38	38	65
Inverted	$\varnothing D$	36	**	60	70	90	100	138	155	**
	E	Stroke + 34	Stroke + 34	Stroke + 30	Stroke + 20	Stroke + 29	Stroke + 24	Stroke + 40	Stroke + 38	**
	F	16	**	20	18	20	20	38	38	**

** Consult Power Jacks Ltd

Note: All dimensions in mm.

Power Jacks metric machine screw jacks can be fitted with a safety nut, which provides 2 safety roles:

1. In the event of excessive wear on the nut thread the load will be transferred from the standard nut to the safety nut. This will also provide visual wear indication as the gap between the safety nut decreases to zero as the standard lifting nut wears.
2. In the unlikely event of catastrophic nut thread failure, the safety nut will sustain the load. The safety of industrial and human cargo is therefore improved.

There are several configurations for each safety nut device as they only work in one load direction. For this reason when ordering please supply a sketch of your application showing load directions.

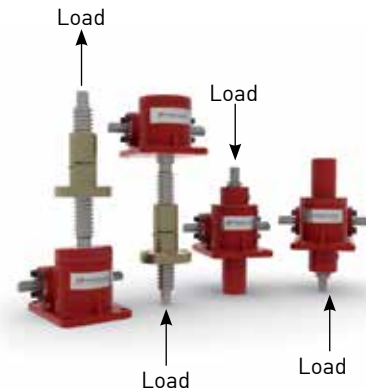

Translating Screw Jacks with Safety Nuts

Translating Metric Screw Jacks with safety nuts are similar in format to the anti-backlash units. Consult Power Jacks for details.

Rotating Screw Jacks with Safety Nuts

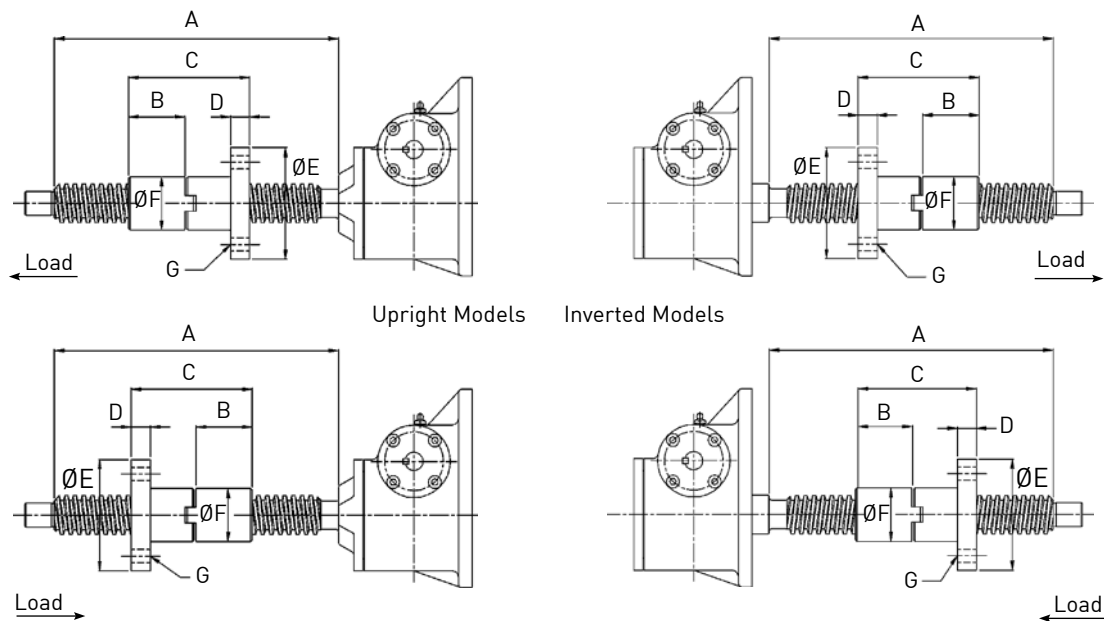

Upright Rotating Screw

Model Number	Rating [kN]	A	B	C	D	E	F	G
UE1803	25	Stroke + 95	33.5	75	15	90	40	4 Holes - 13.5 Dia. on 65 Dia. PCD
UE1806	50	Stroke + 140	58	125	20	115	55	4 Holes - 18 Dia. on 85 Dia. PCD
UE1811	100	Stroke + 170	67	145	25	160	80	4 Holes - 22 Dia. on 120 Dia. PCD
UE1821	200	Stroke + 170	67	25	25	185	90	4 Holes - 26 Dia. on 135 Dia. PCD

Inverted Rotating Screw

Model Number	Rating [kN]	A	B	C	D	E	F	G
DE1803	25	Stroke + 95	33.5	75	15	90	40	4 Holes - 13.5 Dia. on 65 Dia. PCD
DE1806	50	Stroke + 140	58	125	20	115	55	4 Holes - 18 Dia. on 85 Dia. PCD
DE1811	100	Stroke + 170	67	145	25	160	80	4 Holes - 22 Dia. on 120 Dia. PCD
DE1821	200	Stroke + 170	67	25	25	185	90	4 Holes - 26 Dia. on 135 Dia. PCD

Note: All dimensions in millimetres.

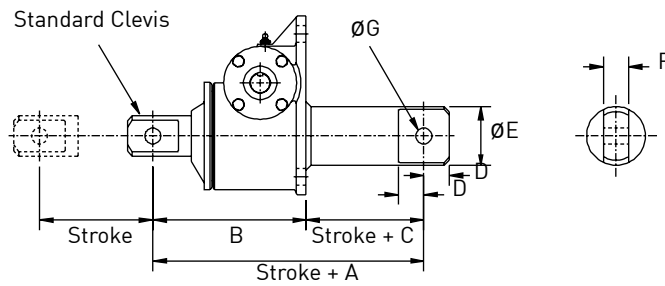
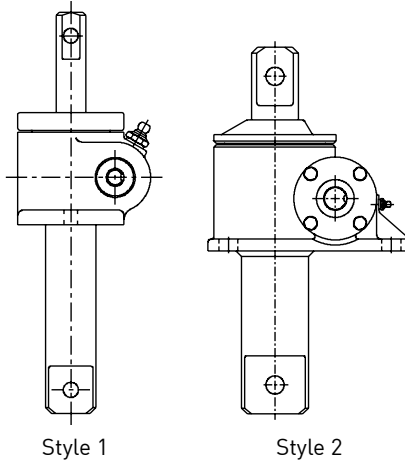

Note: For other performance and dimension information refer to translating screw models.

Model	CCE 2625	CCE 2501	CCE 1802	CC 1805	CCE 1810	CCE 1820	CCE 1830	CCE 1850
Capacity (kN)	5	10	25	50	100	200	300	500
Style	1	1	2	2	2	2	2	2
A	150	180	213	260	352	428	492	570
B	115	145	470	210	247	313	367	440
C	35	35	43	50	105	115	125	130
D	15	20	23	30	33	40	60	75
E	26.7	33.4	48.3	60.3	73	102	141	168
F	15	20	30	35	40	50	80	110
ØG	10	12	16	20	22	30	45	60
Max Stroke at Rated Load (Compression)	220	175	352	420	593	592	1338	1920

Note: All dimensions in millimetres unless otherwise stated.

Configuration A

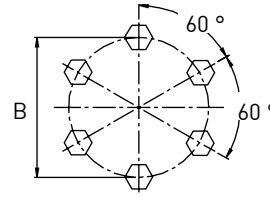
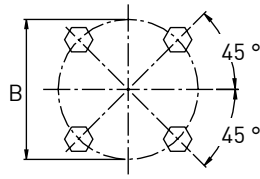

Configuration B

Model	'B' Bolt PCD (mm)	Bolt Information	Configuration
E2625	N/A	N/A	N/A
E2501	N/A	N/A	N/A
E1802	46	M6 X 1mm Pitch, 14mm Deep	A
E1805	61	M8 X 1.25mm Pitch, 22mm Deep	A
E1810	70	M8 X 1.25mm Pitch, 14mm Deep	A
E1820	88	M10 X 1.5mm Pitch, 14mm Deep	A
E1830	107	M10 X 1.5mm Pitch, 19mm Deep	A
E1850	135	M16 X 2mm Pitch, 25mm Deep	A
E18100	160	M16 X 2mm Pitch, 28mm Deep	B

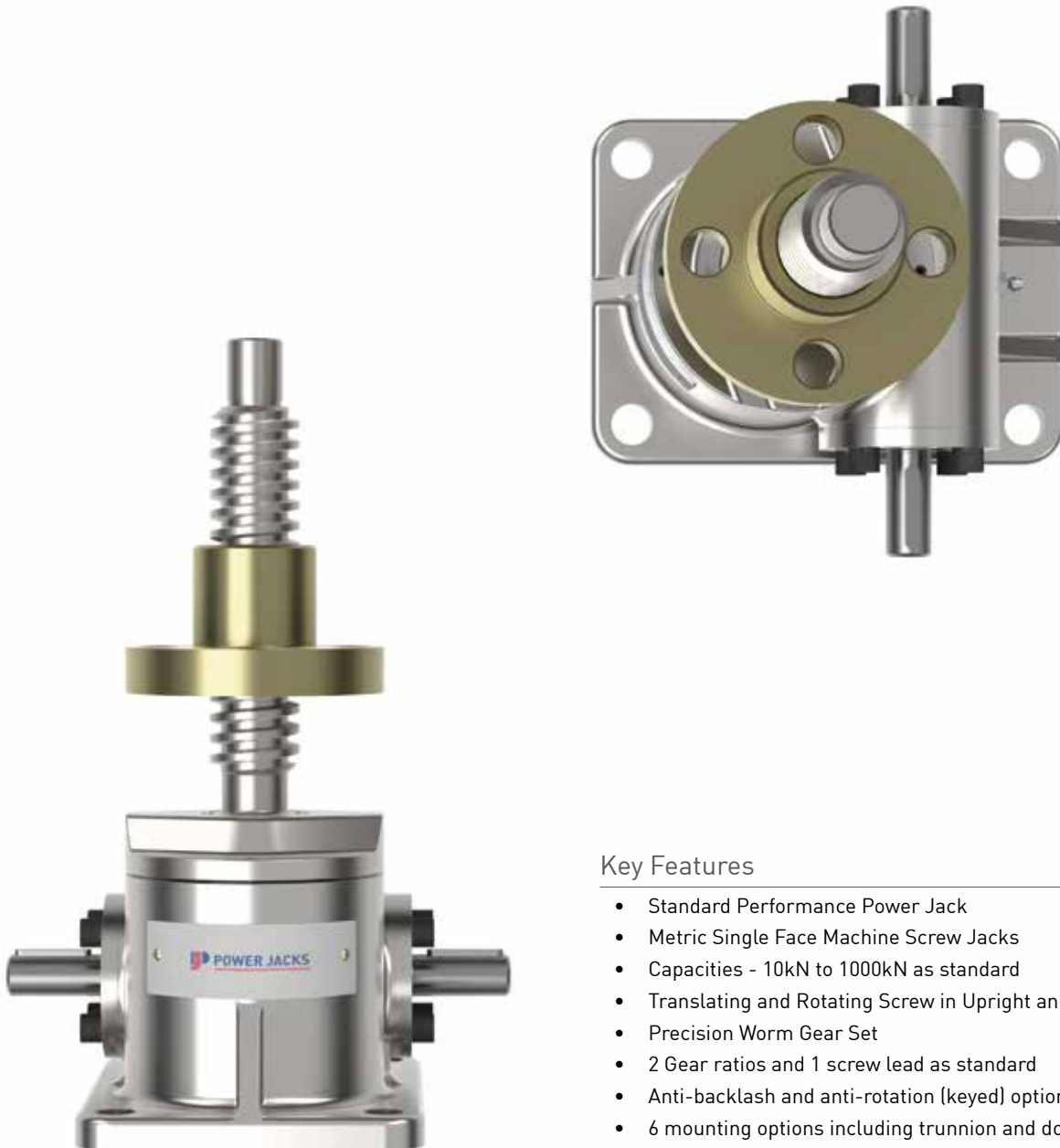

Key Features

- Standard Performance Power Jack
- Metric Single Face Machine Screw Jacks
- Capacities - 10kN to 1000kN as standard
- Translating and Rotating Screw in Upright and Inverted types
- Precision Worm Gear Set
- 2 Gear ratios and 1 screw lead as standard
- Anti-backlash and anti-rotation (keyed) options
- 6 mounting options including trunnion and double clevis
- Sealed gearbox design available
- Special custom designs available

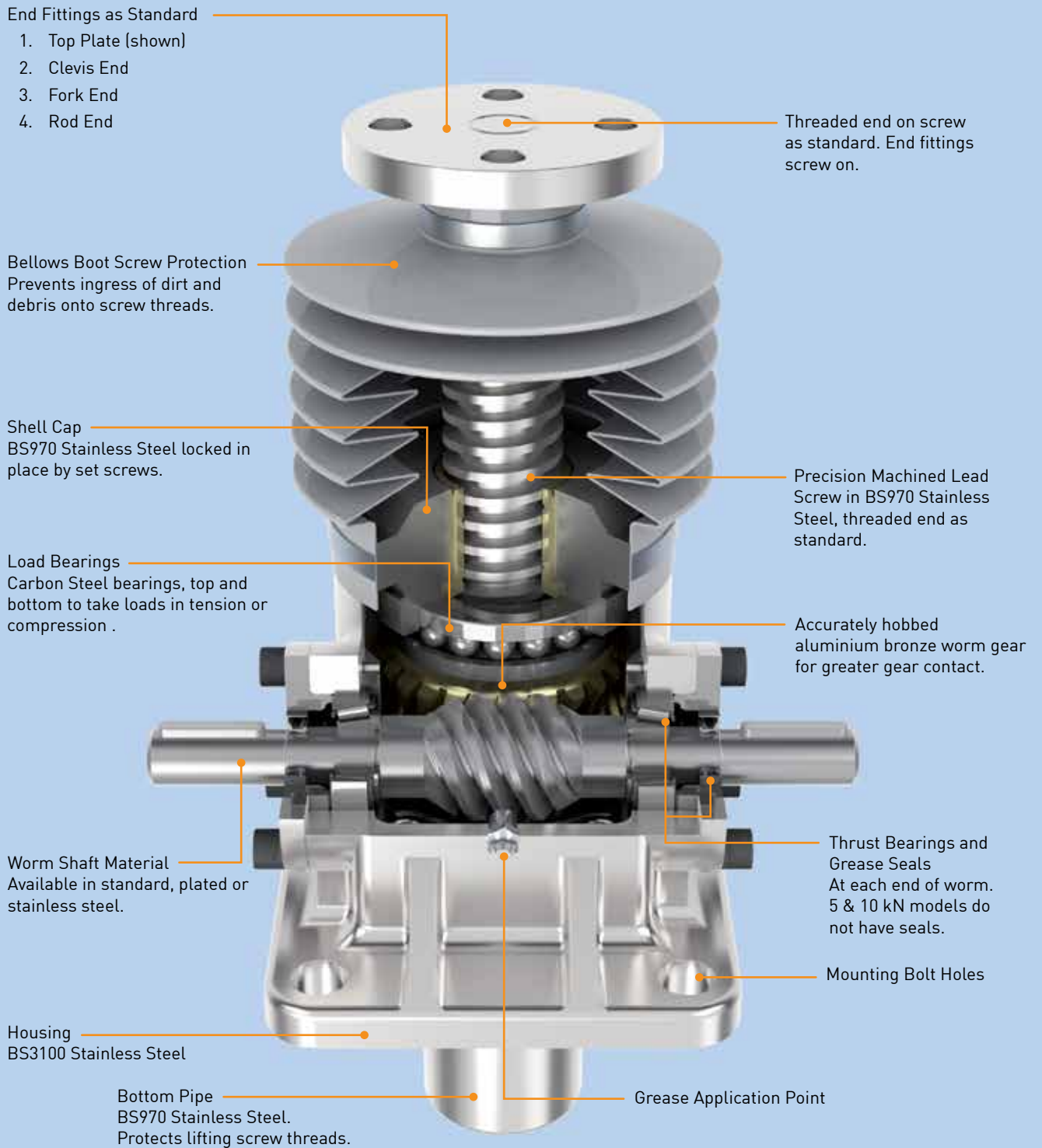

The stainless steel screw jacks are ideal for use in harsh or corrosive environments such as marine, nuclear, water, food processing or paper making machinery, where standard materials may be inadequate.

Translating Screw



Upright



Inverted

Rotating Screw



Upright



Inverted

Typical Applications

Stainless Steel Machine Screw Jacks are typically used in harsh or corrosive environments or those with a regular wash down requirement. Industries such as Marine, Water Treatment, Nuclear, Food Processing, Offshore, Pulp and Paper use stainless steel screw jacks. For each application, variants with different material grades or plated components can be used, tailoring the product for the specific application and budget.

Selecting the Right Screw Jack

Consider all application constraints then choose a product that looks suitable for the intended application. Calculate the power and torque requirements. This is a 5 step process:

- Screw Jack Input Speed (RPM)
- Operating Input Power (kW)
- Operating Input torque (Nm)
- Screw Jack Start-up Torque (Nm)
- Mechanical Power and Torque Check

Special Designs

1. Modifications to the standard screw jacks

This would include non-standard painting or plating of the housing, 2 or 3 start threaded lifting screws, stainless steel lifting screws or worm shafts, increased closed heights, extended worm shafts, opposite threading of lifting screws, etc.

2. Additions to the standard screw jacks

Items such as wear indicators, safety nuts, rotation monitoring kits, special lifting screw end fittings, encoder adapter flanges, etc.

3. Completely special screw jacks

Where a modification of our existing range is not practical we have the facilities to design and manufacture screw jacks tailored specifically to your requirements.

Systems

The screw jacks can be connected together in systems so that multiple units can be operated and controlled together. These jacking system arrangements or configurations can be built in many formats with the use of bevel gearboxes, motors, reduction gearbox, drive shafts, couplings, plumber blocks and motion control devices.

The use of bevel gearboxes allows the distribution of drive throughout a jacking system. The gearboxes come in 2,3 and 4 way drive types. See Neeter Drive Bevel Gearboxes brochure for more details.

Bevel gearboxes and other system components can also be supplied in stainless steel or other corrosion resistant designs.

Two of the most popular system configurations are the 'H' and 'U' configured jacking systems. Remember that multiple screw jacks can be linked together mechanically or electrically. The latter is useful if there is no space for linking drive shafts.



If multiple machine screw jacks are connected in a mechanically linked system then the complete system may be considered self-locking. If you would like this checked consult Power Jacks. Alternatively, to be sure, include a brake on the system either as a stand alone device or as a brake motor.

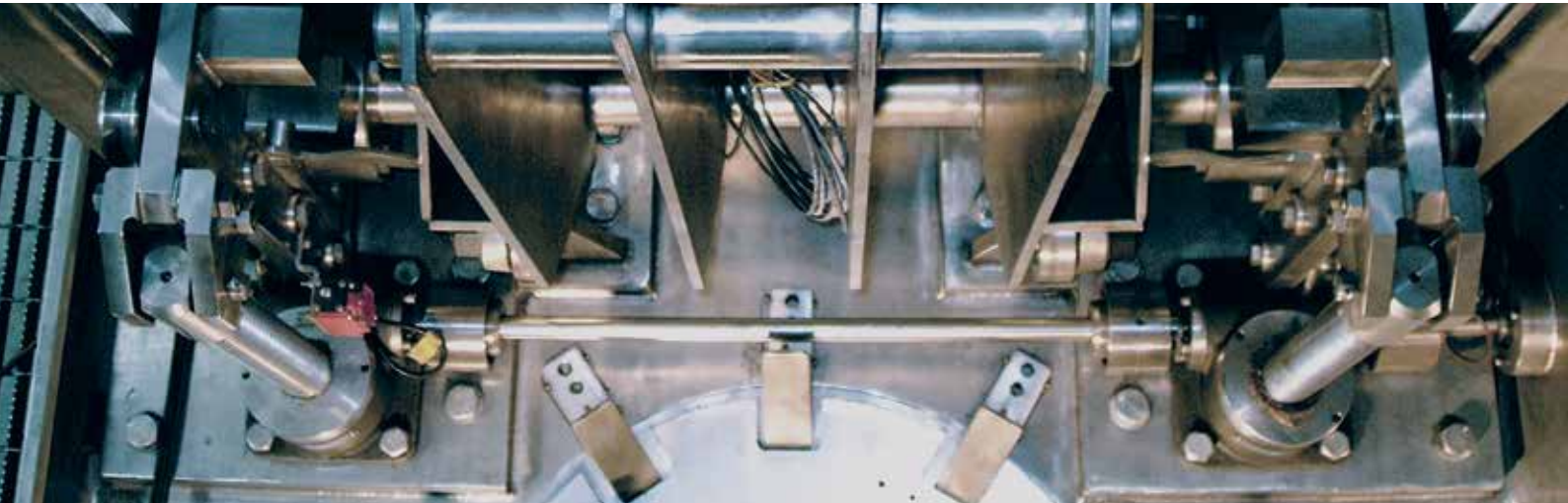

DRUM POSTING EQUIPMENT (DPE)

Dunreay cementation plant waste transfer facility.

Raise and lower drum transfer table.

Two stainless steel E-Series translating machine screw jacks type CE-1810-1805-1 connected in series by a stainless steel drive shaft and geared couplings.

For more application examples see the 'Power at Work' brochure or www.powerjacks.com.



Stainless Steel Screw Jack Standard Performance

Model		S-E2501	S-E1802	S-E1805	S-E1810	S-E1820	S-E1830	S-E1850	S-E18100	
Capacity	kN	10	25	50	100	200	300	500	10000	
Sustaining Capacity (kN) 1	Tension	6.6	16.5	33	66	132	200	333	666	
	Compression	10	25	50	100	200	300	500	1000	
Operating Capacity (kN) 2	Stainless Steel Worm Shaft	3.3	8.25	16.5	33	66	100	167	333	
	Plated Worm Shaft	Tension	6.6	16.5	33	66	132	200	333	666
		Compression	10	25	50	100	200	300	500	1000
Lifting Screw 3	Diameter (mm)	20	30	40	55	65	95	120	160	
	Pitch (mm)	5	6	9	12	12	16	16	20	
Gear ratios	Option 1	5:1	6:1	6:1	8:1	8:1	10 2/3	10 2/3:1	12:1	
	Option 2	20:1	24:1	24:1	24:1	24:1	32:1	32:1	36:1	
Turn of worm for travel of lifting screw	Option 1	1 for 1mm	1 for 1mm	1 for 1.5mm	1 for 1.5mm	1 for 1.5mm	1 for 1.5mm	1 for 1.5mm	3 for 5mm	
	Option 2	4 for 1mm	4 for 1mm	4 for 1.5mm	2 for 1mm	2 for 1mm	2 for 1mm	2 for 2mm	9 for 5mm	
Max. Input power (kW)	Option 1	0.375	1.5	3.0	3.75	3.75	6.0	11.25	18.5	
	Option 2	0.19	0.375	0.55	1.125	1.125	1.9	4.5	8.25	
Start up torque at full load (Nm) 4	Option 1	2.3	6.5	18.5	38.2	87	160	301	675	
	Option 2	1.0	2.9	8.4	19.9	45	95	168	373	
Weight (kg) - stroke = 150mm		2.27	8.17	15.88	24.72	45	86	195	553	
Weight (kg) per extra 25mm		0.13	0.21	0.32	0.57	0.86	1.58	2.49	4.31	
Option 1	Gear Ratio	5	6	6	8	8	10.66	10 2/3	12	
	Screw Jack Static Efficiency	0.233	0.201	0.213	0.206	0.181	0.149	0.132	0.131	
	Screw Jack Dynamic Efficiency	0.306	0.264	0.281	0.272	0.242	0.205	0.181	0.178	
Option 2	Gear Ratio	20	24	24	24	24	32	32	36	
	Screw Jack Static Efficiency	0.130	0.115	0.117	0.132	0.116	0.084	0.079	0.079	
	Screw Jack Dynamic Efficiency	0.194	0.167	0.172	0.190	0.169	0.128	0.120	0.123	

Notes

1. Sustaining capacity for tension is less than screw jack rating due to the performance of the stainless steel lifting screw. If a tension sustaining capacity is required equal to the screw jack rating consult Power Jacks Ltd.
2. Operational rating is less than sustaining rating due to the performance of stainless steel worm shafts. If a operating capacity is required equal to sustaining capacity consult Power Jacks for worm shaft options such as Chrome or Electroless-Nickel plating.
3. All metric stainless steel machine screws have a trapezoidal thread form, single start as standard.
4. Based on operating capacity for loads of 25% to 100% of screw jack capacity, torque requirements are approximately proportional to the load.
5. Efficiency values for standard grease lubricated worm gear box and lifting screw

External dimensions same as for Metric Machine Screw Jacks.

Metric Ball Screw Jack

A BALL-BEARING TYPE HEAT-TREATED SCREW AND MATING NUT WITH ROLLING CONTACT REDUCES FRICTION TO A BARE MINIMUM IN CONVERTING TORQUE TO THRUST.

Overall operating efficiency is as high as 70% in some models, depending on the worm gear ratio.

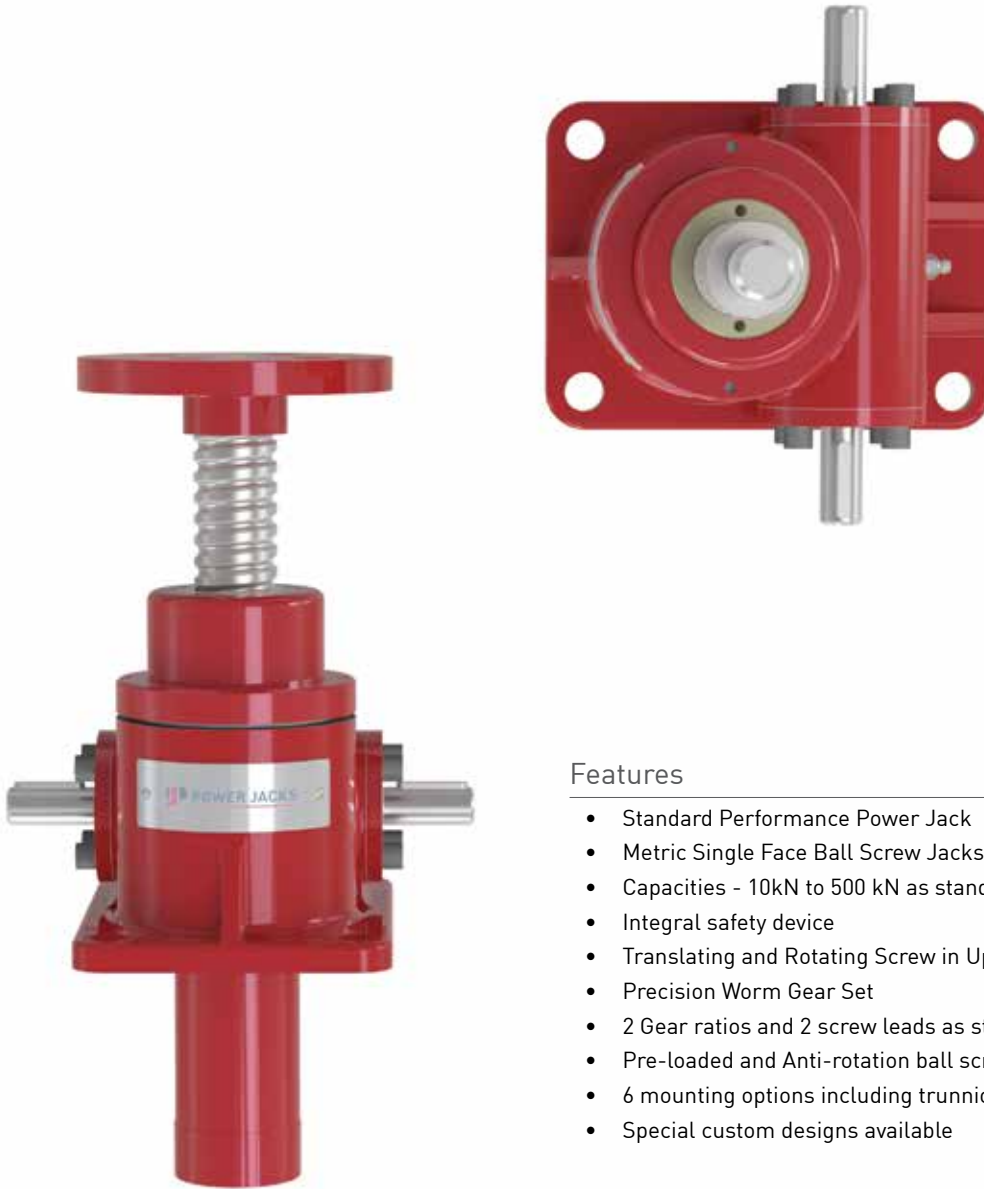

Features

- Standard Performance Power Jack
- Metric Single Face Ball Screw Jacks
- Capacities - 10kN to 500 kN as standard
- Integral safety device
- Translating and Rotating Screw in Upright and Inverted types
- Precision Worm Gear Set
- 2 Gear ratios and 2 screw leads as standard
- Pre-loaded and Anti-rotation ball screw options
- 6 mounting options including trunnion and double clevis
- Special custom designs available

End Fittings as Standard

1. Top Plate (shown)
2. Clevis End
3. Fork End
4. Rod End

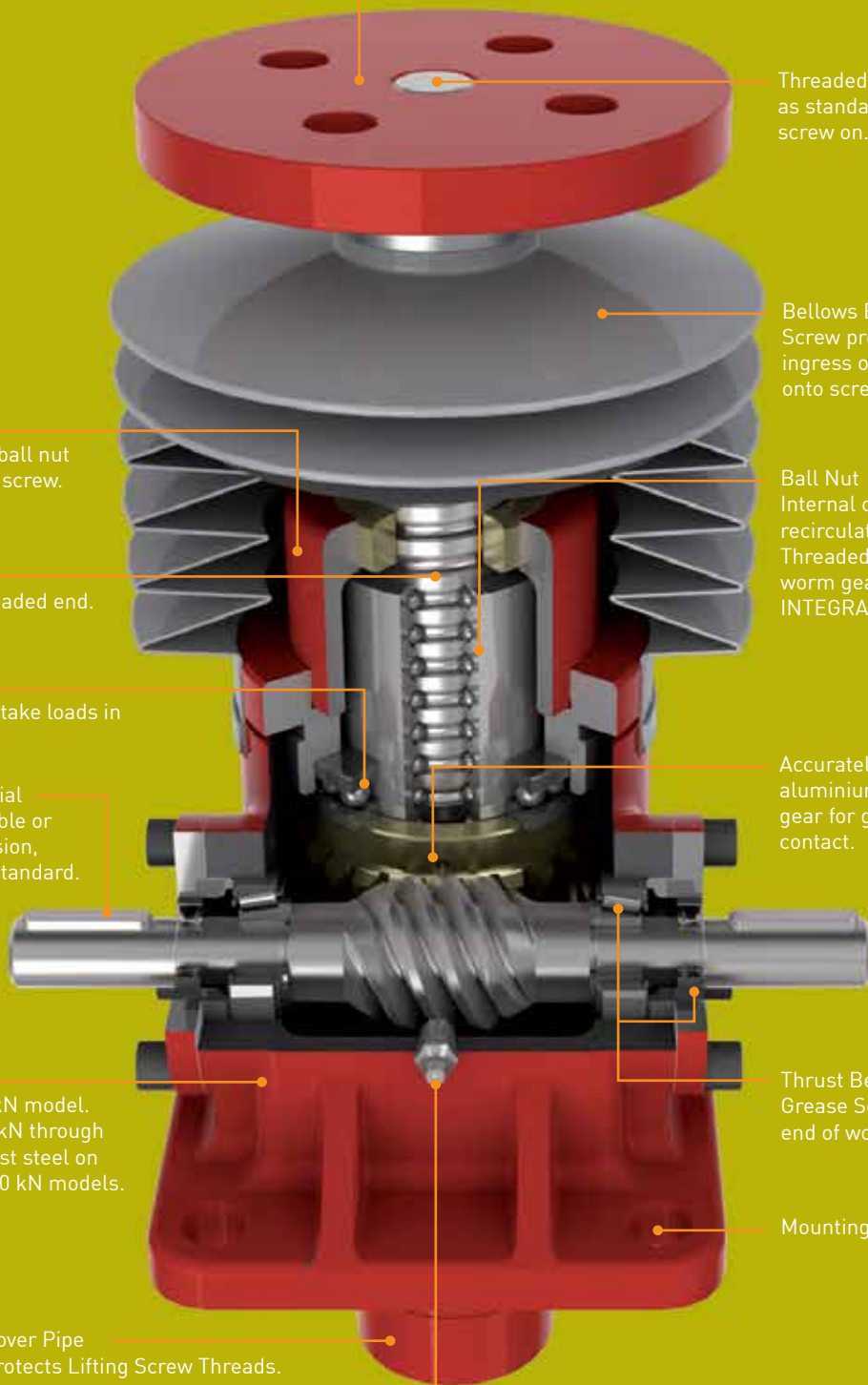

Threaded end on screw as standard. End fittings screw on.

Bellows Boot
Screw protection prevents ingress of dirt and debris onto screw threads.

End Cap
Protective cap for ball nut with guide for ball screw.

Ball Nut
Internal continuous recirculation of steel balls. Threaded and secured to worm gear. Equipped with INTEGRAL SAFETY DEVICE.

Ball Screw
Standard with threaded end.

Load Bearings
Top and bottom to take loads in either direction.

Accurately hobbled aluminium bronze worm gear for greater gear contact.

Worm Shaft Material
Available with double or single shaft extension, fitted with key as standard.

Housing
Aluminium on 10 kN model. Ductile iron on 25 kN through 100 kN models, cast steel on 200 kN through 500 kN models.

Thrust Bearings and Grease Seals at each end of worm.

Mounting Bolt Holes.

Cover Pipe
Protects Lifting Screw Threads.

Grease Application Point.

Translating Screw



Upright

Inverted

Rotating Screw



Upright

Inverted

Typical Applications

Ball Screw Jacks are generally used when the application has a relatively high duty cycle or the input power for a given screw jack is to be minimised. The high efficiency of the ball screw & nut significantly increase the efficiency of a screw jack in comparison to a Machine Screw Jack. Due to their high efficiency they nearly always require a brake to hold position. They are used in a wide variety of applications including Automotive, Steel, Glass, Defence, Nuclear and Solar industries.

Selecting the Right Screw Jack

Consider all application constraints then choose a product that looks suitable for the intended application. Calculate the power and torque requirements. This is a 5 step process:

- Screw Jack Input Speed (RPM)
- Operating Input Power (kW)
- Operating Input Torque (Nm)
- Screw Jack Start-up Torque (Nm)
- Mechanical Power and Torque Check

Special Designs

1. Modifications to the standard screw jacks

This would include non-standard painting or plating of the housing, high lead ball screws, stainless steel ball screws or worm shafts, increased closed heights, extended worm shafts, opposite threading of ball screws, etc.

2. Additions to the standard screw jacks

Items such as wear indicators, safety nuts, rotation monitoring kits, special ball screw end fittings, encoder adapter flanges, etc.

3. Completely special screw jacks

Where a modification of our existing range is not practical we have the facilities to design and manufacture screw jacks tailored specifically to your requirements.

Systems

The screw jacks can be connected together in systems so that multiple units can be operated and controlled together. These jacking system arrangements or configurations can be built in many formats with the use of bevel gearboxes, motors, reduction gearbox, drive shafts, couplings, plumber blocks and motion control devices.

The use of bevel gearboxes allows the distribution of drive throughout a jacking system. The gearboxes come in 2,3 and 4 way drive types. See Neeter Drive Bevel Gearboxes brochure for more details.

Bevel gearboxes and other system components can also be supplied in stainless steel or other corrosion resistant designs.

Two of the most popular system configurations are the 'H' and 'U' configured jacking systems. Remember that multiple screw jacks can be linked together mechanically or electrically. The latter is useful if there is no space for linking drive shafts.



If multiple ball screw jacks are connected in a mechanically linked system then the complete system in some circumstances may be considered self-locking depending on the gear ratios and efficiencies of units in the system. In general, Power Jacks recommend a brake is used on **ALL** Ball Screw Jack systems. If you would like this checked, consult Power Jacks. Alternatively, to be sure, include a brake on the system either as a stand alone device or as a brake motor.



CAVENDISH LABORATORY ANTENNA DISH

Position adjustment of Arcminute Microkelvin Imager (AMI) to achieve a pointing accuracy of better than half a minute of arc (1/120 of a degree). 10 x antenna dishes all in close proximity of each other. Measuring the weight of the universe by analysing "dark matter".

10 x off 50kN E-Series CE3805-1050-BHS metric ball screw jacks in translating screw configuration with a stroke of 1050mm. These ball screw jacks operate in normal UK outdoor conditions and allow the antenna to operate at wind speeds of up to 50mph.

For more application examples see the 'Power at Work' brochure or www.powerjacks.com.



Screw Jack Standard Performance

Model	E28501	E3802		E3805		E3810		E3820		E3830	E3860
Capacity (kN)	10	25		50		100		200		300	500
Lifting Screw	Diameter (mm)	20	25		40		50		63		80
	Pitch (mm)	5	5	10	10	20	10	20	10	20	20
Gear Ratios	Option 1	5:1	6:1		6:1		8:1		8:1		10 2/3:1
	Option 2	20:1	24:1		24:1		24:1		24:1		32:1
Turn of worm for travel of Lifting Screw	Option 1	10 for 10mm	12 for 10mm	6 for 10mm	6 for 10mm	3 for 10mm	8 for 10mm	4 for 10mm	8 for 10mm	4 for 10mm	5.33 for 10mm
	Option 2	40 for 10mm	48 for 10mm	24 for 10mm	24 for 10mm	12 for 10mm	24 for 10mm	12 for 10mm	24 for 10mm	12 for 10mm	16 for 10mm
Maximum Input Power (kW)	Option 1	0.375	1.5		3		3.75		3.75		6
	Option 2	0.18	0.375		0.55		1.125		1.125		1.9
Start-up Torque at full load (Nm) †	Option 1	2.7	5.9	11.1	23.4	44.6	36.4	68.5	75.2	139.4	182
	Option 2	1.2	2.6	4.9	10.7	20.4	19.1	35.8	39.4	72.9	107.3
Weight (kg) - stroke = 150mm	2.8	8.17		15.88		24.72		45		86	
Weight (kg) - per extra 25mm	0.08	0.21		0.32		0.57		0.86		1.58	

On request

† For loads of 25% to 100% of screw jack capacity, torque requirements are approximately proportional to the load.

Efficiency - Option 1 Gear Ratio

Model	E28501	E3802		E3805		E3810		E3820		E3830	E3860
Gear Ratio	5:1	6:1		6:1		8:1		8:1		10 2/3:1	Available on Request
Lifting Screw Lead (mm)	5	5	10	10	20	10	20	10	20	20	
Static Efficiency	0.603	0.565	0.600	0.567	0.595	0.546	0.581	0.529	0.571	0.492	
Dynamic Efficiency	0.681	0.662	0.692	0.663	0.687	0.645	0.674	0.631	0.665	0.595	

Efficiency - Option 2 Gear Ratio

Model	E28501	E3802		E3805		E3810		E3820		E3830	E3860
Gear Ratio	20:1	24:1		24:1		24:1		24:1		32:1	Available on Request
Lifting Screw Lead (mm)	5	5	10	10	20	10	20	10	20	20	
Static Efficiency	0.341	0.320	0.340	0.310	0.325	0.348	0.370	0.337	0.364	0.278	
Dynamic Efficiency	0.429	0.419	0.438	0.407	0.422	0.450	0.470	0.440	0.465	0.371	

Note

1. Efficiency values for standard grease lubricated worm gear box and lifting screw.

Plan View

Model:
E28501

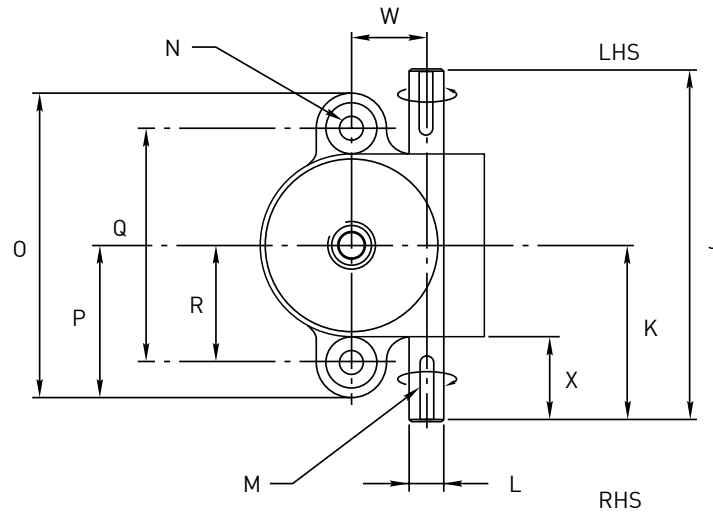

Plan View

Models:
E3802, E38021, E3805, E38051, E3810,
E38101, E3820, E38201, E3830, E3860

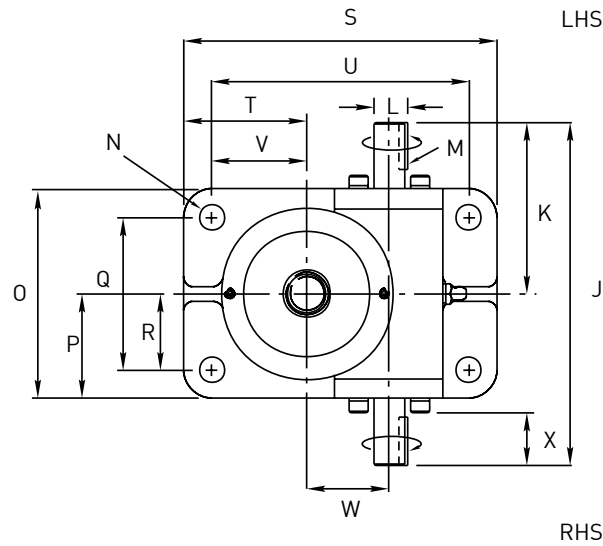

Note

1. All dimensions in mm
3. LHS = Left Hand Side
4. RHS = Right Hand Side.

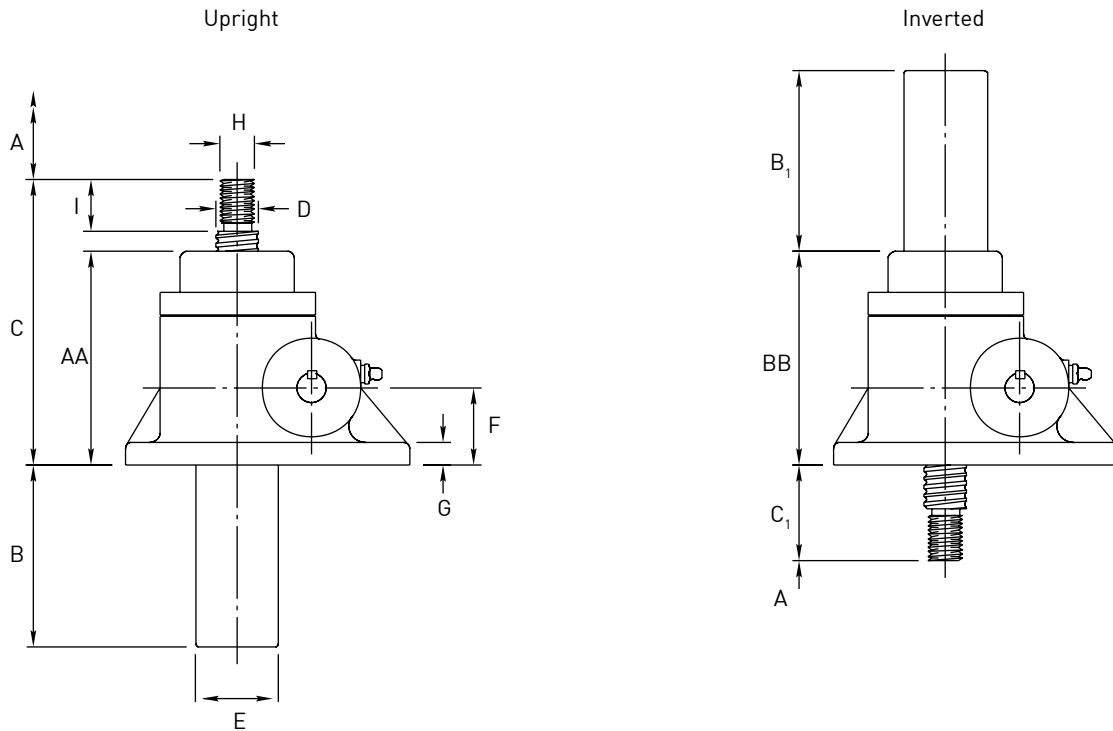

Model	Upright	E28051	E3802	E38021	E3805	E38051	E3810	E38101	E3820	E3830	E3860
	Inverted	E28500	E3801	E38011	E3804	E38041	E3809	E38091	E3819	E3829	E3859
Capacity (kN)		10	25		50		100		200	300	500
A		Stroke as Required									
B		A+35	A+10		A+10		A+15		A+10	A+30	
B ₁		A+35	A+25		A+25		A+25		A+25	A+25	
C		150	175	202	218	269	252	275	338	386	445
C ₁		45	55		65		80		95	115	
D		20	25		40		50		63	80	
E		42	48.3		60.3		73		89	115	
F		40 ± 0.13	45 ± 0.13		60 ± 0.13		60 ± 0.13		85 ± 0.13	105 ± 0.13	
G		9	13		14		16		20	30	
H		M12 x 1.75	M20 x 2.5		M24 x 3		M36 x 4		M48 x 5	M72 x 4	
I		24	30		35		40		55	65	
J		150	180		230		280		300	380	
K		75	90		115		140		150	190	
øL		14 h8	16 h8		19 h8		25 h8		28 h8	35 h8	
M		5 x 5 x 25	5 x 5 x 25		6 x 6 x 32		8 x 7 x 40		8 x 7 x 40	10 x 8 x 50	
N		11	13.5		18		22		26	39	
O		130	110		150		190		210	260	
P		65	55		75		95		105	130	
Q		100	80		115		145		150	190	
R		50	40		57.5		72.5		75	95	
S		-	165		205		225		275	365	
T		-	65		75		75		105	140	
U		-	135		170		180		215	295	
V		-	50		57.5		52.5		75	105	
W		31.75 + 0.076 - 0.000	43.26 + 0.025 - 0.025		55.58 + 0.050 - 0.000		66 + 0.060 - 0.000		66 + 0.070 - 0.000	95.25 + 0.130 - 0.000	
X		36	27.5		35		44		44	56	
AA		114	134	161	172	223	197	220	268	316	360
BB		114	134	161	172	223	197	220	268	316	360

Available on Request

Note

1. All dimensions in mm.

For other dimensions and performance data refer to translating screw jacks.

Upright

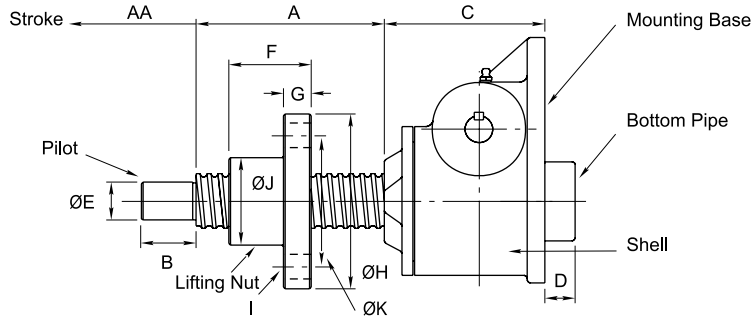

Model	UE28502	UE3803	UE38031	UE3806	UE38061	UE3811	UE38111	UE3821	UE38211	UE3831	UE3861
Capacity (kN)	10	25		50		100		200		300	500
A	AA + 74	AA + 85	AA + 110	AA + 110	AA + 160	AA + 135	AA + 160	AA + 176	AA + 190	AA + 240	Available on Request
B	16	25		30		50		65		85	
C	90	103.5		138		146.5		195		235	
D	34	0		0		28		24		40	
ØE	12	20		25		35		45		75	
F	44	65	96	90	136	108	132	150.5	160	200	
G	12	15		20		25		35		48	
H	55	90		120		155		185		230	
I	6 x Ø7	4 x Ø13.5		4 x Ø18		4 x Ø22		4 x Ø26		4 x Ø26	
ØJ	32	40	47	60	70	75	85	95	120		
ØK(PCD)	45	65		90		115		135		175	

Inverted

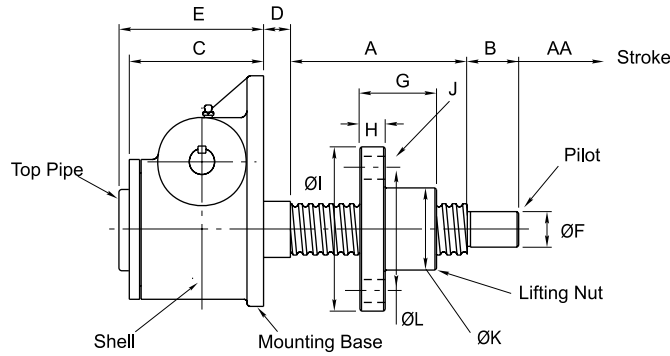

Model	DE28502	DE3803	DE38031	DE3806	DE38061	DE3811	DE38111	DE3821	DE38211	DE3831	DE3861
Capacity (kN)	10	25		50		100		200		300	500
A	AA + 74	AA + 85	AA + 110	AA + 110	AA + 160	AA + 135	AA + 160	AA + 176	AA + 190	AA + 240	Available on Request
B	16	25		30		50		65		85	
C	90	95.5		122		130.5		179		235	
D	10	13.5		18		26.5		25		25	
E	90	95.5		122		130.5		203		275	
ØF	12	20		25		35		45		75	
G	44	65	96	90	136	108	132	150.5	160	200	
H	12	15		20		25		35		48	
ØI	55	90		120		155		185		230	
J	6 x Ø7	4 x Ø13.5		4 x Ø18		4 x Ø22		4 x Ø26		4 x Ø26	
ØK	32	40	47	60	70	75	85	95	120		
ØL(PCD)	45	65		90		115		135		175	

Note: 1. PCD = Pitch Circle Diameter.

Power Jacks ball nut employs the internal ball transfer system for recirculating the balls. This design provides for:

- Robust design
- Small ball nut body outer diameter
- Smooth movement
- Less turns per circuit
- Absence of parts liable to wear.

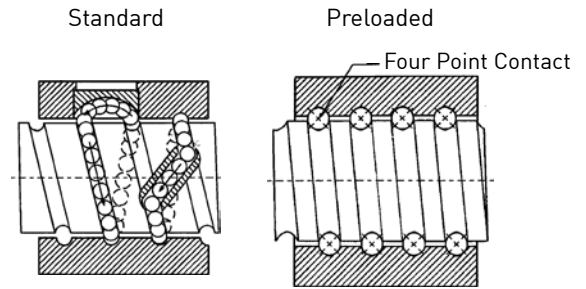

Solid formed nylon wiper seals on the ball nut prevents ingress of foreign matter and retain lubrication within the nut.

Integral Safety Device

All Power Jacks Metric Ball Screw Jacks have an integral safety device as standard. This provides two important safety roles:

1. In the unlikely event of an excessive wear in the ball screw drive, the safety device will contact the screw shaft and act as an “ACME” Thread. This will provide early warning of any possible ball screw failure and is capable of providing drive in the event of any such failure. This can allow a control system to alert an operator to wear of this kind by monitoring the increase in motor current required to drive the system due to the increased friction generated by the device.
2. It allows the ball nut on the screw jack to sustain a load in the event of catastrophic ball failure. The safety of industrial and human cargo is therefore improved. Ball screw systems without this device could collapse under load or drop the carried load.

Note: Model E28501 ball screw jack does not have safety device as standard, if required consult Power Jacks Ltd.

Preloaded for Reduced Axial Backlash

Metric Ball Screw Jacks can be provided with preloaded ball nuts to give reduced axial backlash as a high efficiency alternative to the metric machine screw anti-backlash option. Preloading on the ball nut is obtained by the “Interference Ball” method. By fitting interference balls in the ball nut to obtain a diametral interference fit and using the ogival track form, a four-point contact results.

Ball Screw Life

Theoretical service life can be expressed in either L_{10} 10^6 revolutions or L_h 10^3 hours or L_d kilometres. As the life of a ball screw is determined by metal fatigue it is not possible to accurately predict life. However, it is practical to suppose that 90% of a sufficiently large number of equally sized ball screws running under equal working conditions will reach L_{10} or L_h without evidence of material fatigue. The L_{10} ball screw life is rated using the Dynamic Capacity, which is the maximum constant axial load that can be applied in running conditions for a life of 1.10^6 revolutions of the ball screw. This can be expressed in linear travel [L_d].

Where L_{10} = Service Life (millions of revolutions)
 L_d = Service Life (km)
 P = Pitch of Ball Screw (mm)

$$L_d = L_{10} * P$$

Model	Linear Travel L_d in km		Working Load [kN]										
	Capacity [kN]	Pitch [mm]	5	10	25	30	50	75	100	150	200	250	300
E28501	10	5	20.5	2.5	-	-	-	-	-	-	-	-	-
E3802	25	5	381	48	3	-	-	-	-	-	-	-	-
E38021	25	10	1 775	222	14	-	-	-	-	-	-	-	-
E3805	50	10	11 978	1 497	96	55	12	-	-	-	-	-	-
E38051	50	20	17 039	2 130	136	79	17	-	-	-	-	-	-
E3810	100	10	32 287	4 036	258	149	32	10	4	-	-	-	-
E38101	100	20	38 503	4 813	308	178	39	11	5	-	-	-	-
E3820	200	10	162 327	20 291	1 299	752	162	48	20	6	3	-	-
E38201	200	20	320 060	40 008	2 560	1 482	320	95	40	12	5	-	-
E3830	300	20	903 882	112 985	7 231	4 185	904	268	113	33	14	7	4

Use the following formulae to calculate the service life in terms of hours running:

Where L_h = Service Life (hours)
 L_{10} = Service Life (revolutions)
 n_m = Mean Screw Jack Input Speed (rpm)
 Gr = Gear Ratio

$$L_h = \frac{L_{10} * Gr}{60 * n_m}$$

Note: 1. Ball screw life based on dynamic load calculated according to DIN69051 Part 4.

4 E-Series - Metric Ball Screw Jack

46 Flange Bolt for Worm Shafts

Model	'B' Bolt PCD (mm)	Bolt Information
E28501	n/a	n/a
E3802	46	M6 x 1mm Pitch, 14mm Deep
E3805	61	M8 x 1.25 Pitch, 22mm Deep
E3810	70	M8 x 1.25 Pitch, 14mm Deep
E3820	88	M10 x 1.5mm Pitch, 14mm Deep
E3830	107	M10 x 1.5mm Pitch, 19mm Deep
E3860	135	M16 x 2mm Pitch, 25mm Deep

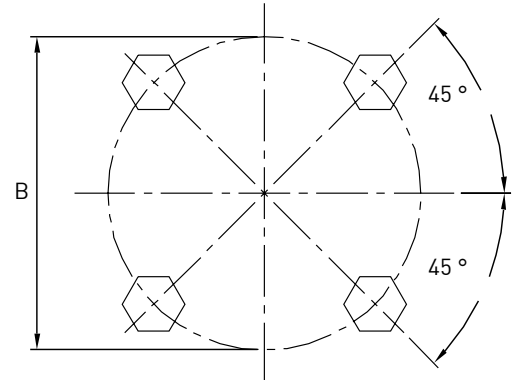

Note

1. All dimensions in millimetres unless otherwise stated.

Double Clevis End Ball Screw Jacks

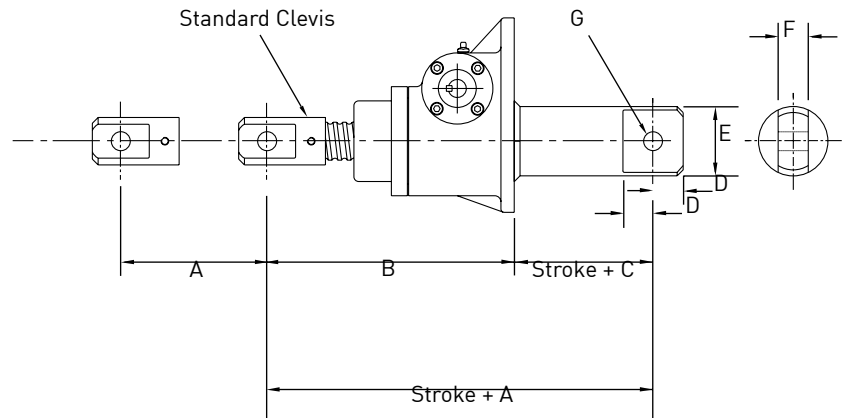

Model	CCE28501	CCE3802	CCE38021	CCE3805	CCE38051	CCE3810	CCE38101	CCE3820	CCE38201	CCE3830	CCE3860
Capacity	10	25	25	50	50	100	100	200	200	300	500
A	Available on Request	260	287	313	364	427	450	525	573	Available on Request	Available on Request
B		202	229	245	296	299	322	386	434		
C		58	58	68	68	128	128	139	139		
D		23	23	30	30	33	33	40	40		
E		48.3	48.3	60.3	60.3	73	73	102	102		
F		30	30	35	35	40	40	50	50		
G		16	16	20	20	22	22	30	30		
Max Raise at Max Rated Load in Compression		280	200	600	560	658	588	769	621		

Note

1. For other performance and dimension information refer to translating screw models.
2. All dimensions in millimetres unless otherwise stated.

The anti-rotation device is available for translating ball screw models only. It is used only when the load to be moved (actuated) may rotate, i.e. the screw is unguided and does not prevent rotation.

The anti-rotation device consists of a square steel tube which guides the movement of a square aluminium bronze guide block fitted to the end of the ball screw. The guide block also acts as a stop nut.

Model	E28501	E3802	E3805	E3810	E3820	E3830	E3860
Capacity (kN)	10	25	50	100	200	300	500
A	AOR	50	70	AOR	AOR	AOR	AOR
B	AOR	50	60	AOR	AOR	AOR	AOR
C	AOR	90	115	AOR	AOR	AOR	AOR
D	AOR	16	20	AOR	AOR	AOR	AOR

Note

1. AOR = Application On Request, consult Power Jacks Ltd.
2. All dimensions in millimetres unless otherwise stated.

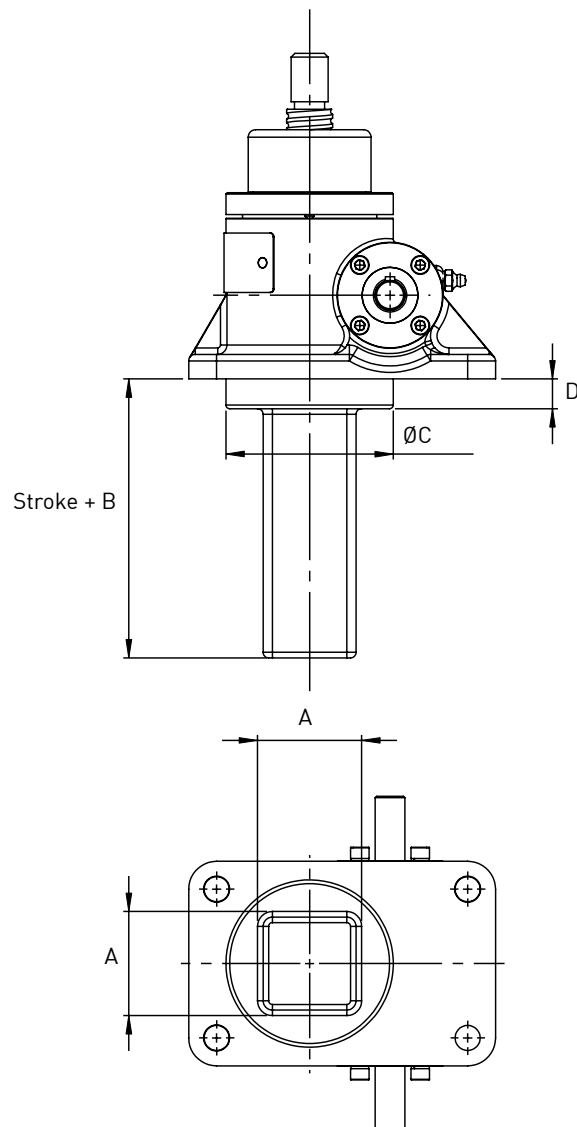

Special Designs

THE E-SERIES SCREW JACKS DESIGN IS FULLY CUSTOMISABLE BY OUR ENGINEERING TEAM TO MEET YOUR EXACT APPLICATION REQUIREMENTS.

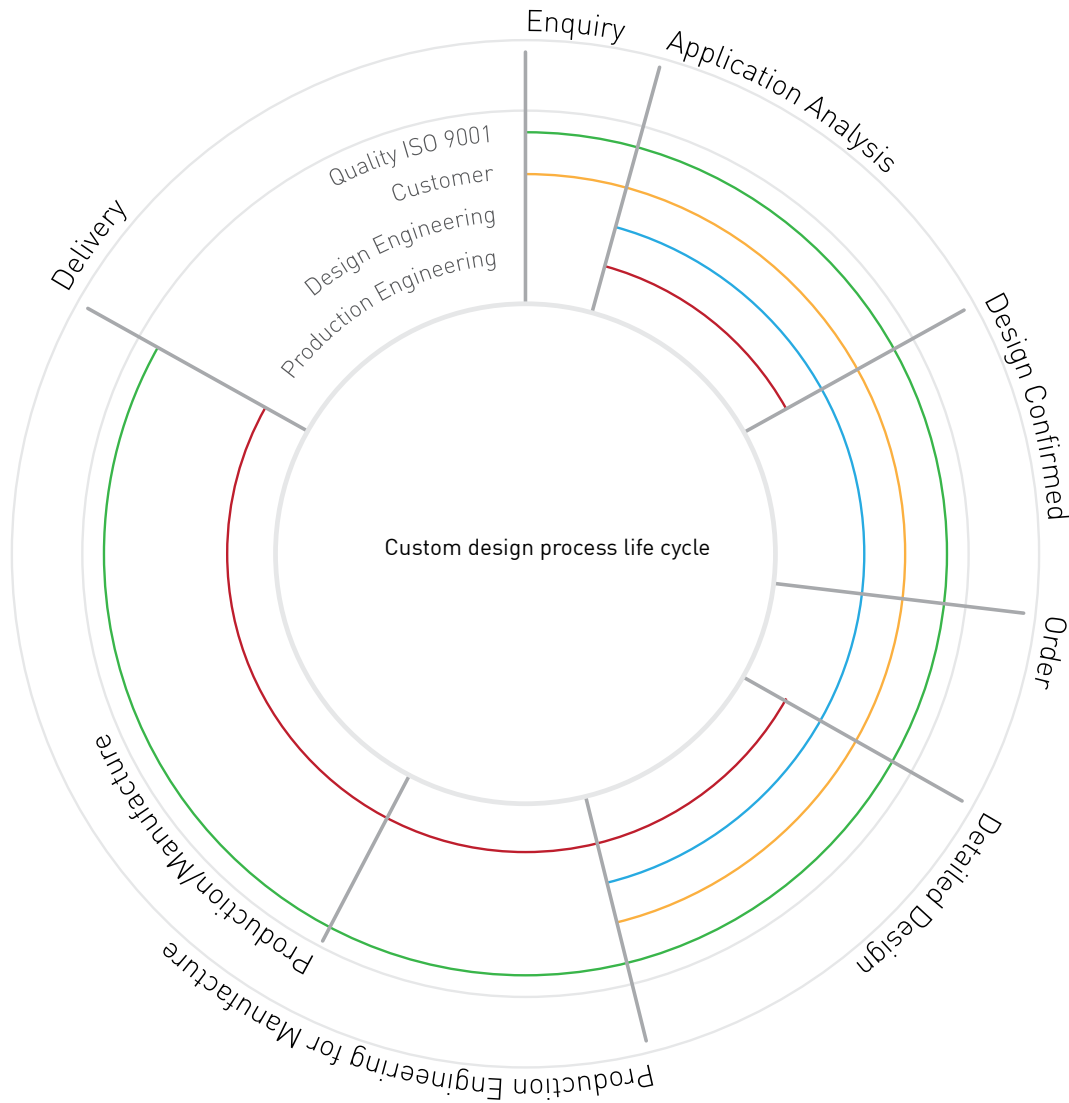

Customised Products

For Power Jacks, every order is different.

We're ready every time to assess the precise requirements of the customer and formulate the right solution.

Off-the-shelf solutions are the norm for many engineering companies. And while they're certainly options for our customers, that's only the case if they're precisely the right options.

We pride ourselves on our adaptability – on our readiness to customise basic models, or even to start from scratch, so that we're providing products that offer optimum performance.

It's a customising service across our entire range of products that means customers get exactly what they need.



An extensive range of axially translating and rotating screw jacks fitted with the patented Spiracon roller screw and designed specifically to customers' application requirements. The Spiracon roller screw is an extremely high performance screw mechanism exhibiting almost no axial backlash and is designed to meet the following demands:

- High precision and repeatable positioning
- High speed
- High dynamic load capacity
- Continuous duty
- High efficiency
- Long life
- Minimum maintenance requirements

The range covers lifting capacities up to 1200 kN, with many design features available to meet the customers' particular requirements. The units' gearbox is based on the standard range of Power Jacks screw jacks, although other gearbox types can be designed for specific applications. The gearboxes are either grease or oil lubricated depending on the application. The roller screw is based around the standard Spiracon planetary roller screw range, with alternative nut housings available to meet the requirements of specific applications.

Principle of Operation

The Spiracon™ system consists of a multi-start screw with an involute thread form and a number of planetary rollers with annular grooves, which engage with the screw. These rollers also engage with a grooved load bearing element, which transmits the load through roller thrust bearings, to the nut housing. The rolling action results in a high efficiency mechanism, while the line contact and hardened and ground construction achieves a high dynamic load carrying capacity, together with almost no axial backlash or wear.

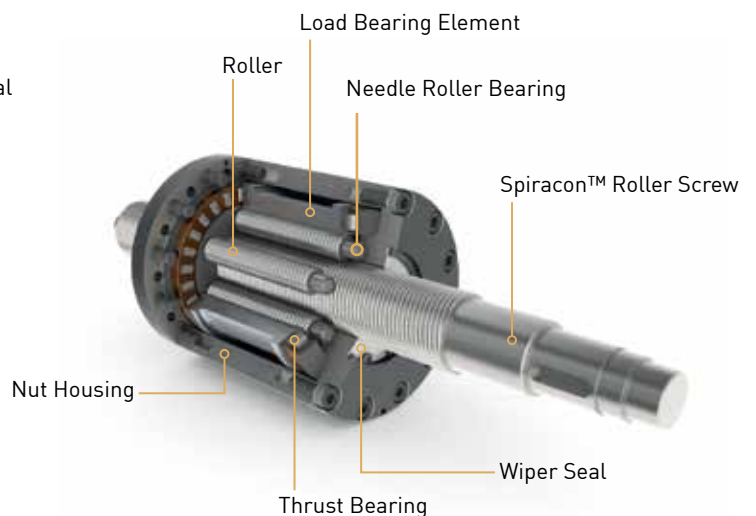
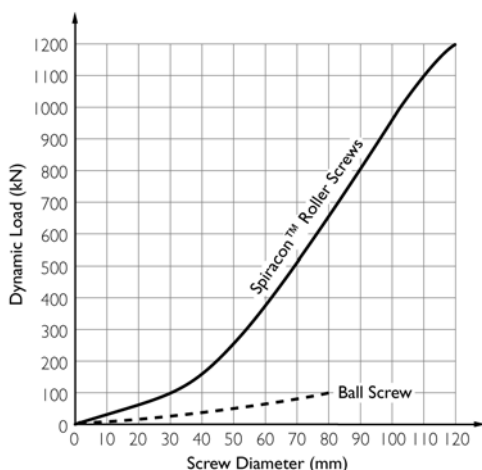

Special Screw Jack Designs

The special screw jacks can be broken down into three categories:

- 1. Modifications to the standard screw jacks
This would include non-standard painting or plating of the housing, 2 or 3 start threaded lifting screws, stainless steel lifting screws or worm shafts, increased closed heights, extended worm shafts, opposite threading of lifting screws, etc.
- 2. Additions to the standard screw jacks
Items such as wear indicators, safety nuts, rotation monitoring kits, special lifting screw end fittings, encoder adapter flanges, etc.
- 3. Completely special screw jacks
Where a modification of our existing range is not practical we have the facilities to design and manufacture screw jacks tailored specifically to your requirements.



50kN
Based on TE1805



50kN
Based on UE1806



25kN
Based on UE1803



200kN
Based on FE4819

Note
1. Units are not to scale on illustration



GRAPHITE HANDLING MACHINE

The Graphite Handling system was developed to retrieve graphite components, capping pieces and thermocouples from inside nuclear reactors, crush them for size reduction and deposit them into shielded flasks. The machine houses 4 types of flask.

The Crusher Jaws are driven by three 50 kN E-Series Screw Jacks, complete with Bevel gearbox, brake and motor, to size reduce the component. The selected Flask is raised into the docking position by two more 50kN screw jacks, driven by a single electric motor via bevel gearboxes. The size reduced component is deposited into the flask and the flask is returned to its storage position.

For more application examples see the 'Power at Work' brochure or www.powerjacks.com.





COIL SPRING LOAD LIMITER

When an industrial machine needs to move a cover or lid onto a dead stop or sealing face it must do so precisely and positively, with contact on all dead stops or over the complete sealing face.

To push the cover into position precisely Power Jacks designed a special coil spring load limiter for the end of the jacks lifting screw.

For more application examples see the 'Power at Work' brochure or www.powerjacks.com.



E-Series

6

Screw Jack Accessories



Top Plate

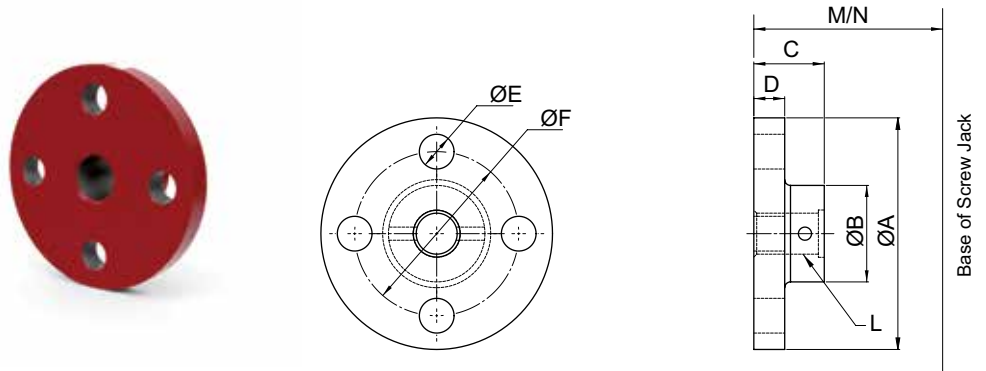

Clevis End

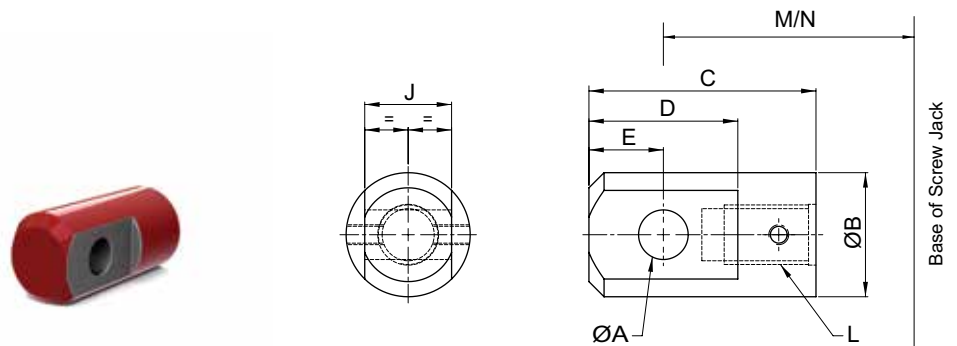

Fork End

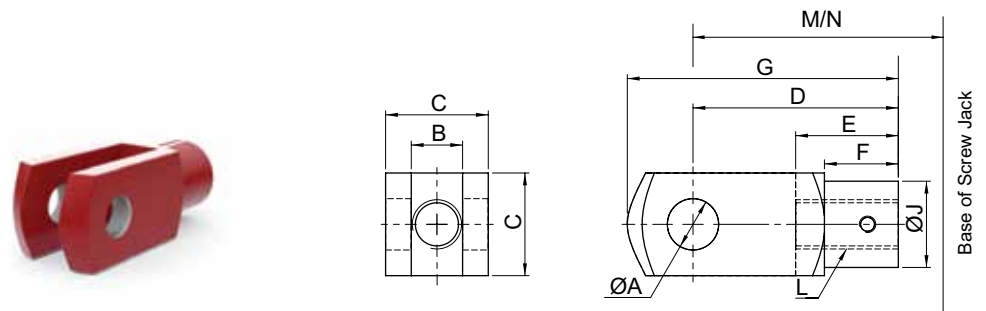

Rod End

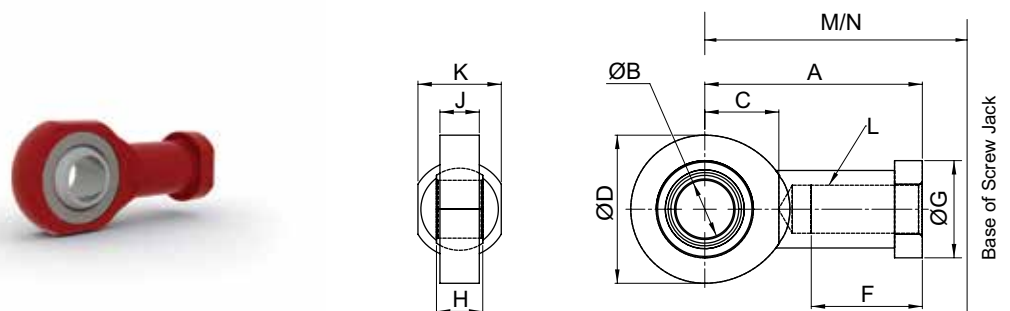

Model		E2626	E2501	E1802	E1805	E1810	E1820	E1830	E1850	E18100	
Top Plate	ØA	65	80	100	120	150	170	240	280	380	
	ØB	25	30	40	50	65	75	110	150	200	
	C	21	24	31.5	36.5	42	58	67	92	127	
	D	8	10	12	16	20	25	30	35	75	
	ØE	9	11	13.5	18	22	26	33	33	51	
	ØF (PCD)	45	55	70	85	110	120	170	215	290	
	L	M10 x 1.5	M12 x 1.75	M20 x 2.5	M24 x 3	M36 x 4	M48 x 5	M72 x 4	M100 x 4	M125 x 4	
	M#1	Upright	95	125	145	185	200	265	325	390	560
		Inverted	40	45	55	65	80	95	115	150	260
	N#2	Upright	-	150	175	218	252	338	445	-	-
Inverted		-	45	55	65	80	95	115	-	-	

Model		E2625	E2501	E1802	E1805	E1810	E1820	E1830	E1850	E18100	
Clevis End	ØA	10	12	16	20	22	30	45	60	90	
	ØB	25	30	40	50	65	75	110	150	200	
	C	56	63	79.5	91.5	120	143	167	217	297	
	D	30	36	46	60	66	80	120	150	210	
	E	15	18	23	30	33	40	60	75	105	
	L	M10 x 1.5	M12 x 1.75	M20 x 2.5	M24 x 3	M36 x 4	M48 x 5	M72 x 4	M100 x 4	M125 x 4	
	J	15	20	30	35	40	50	80	110	140	
	M#1	Upright	115	145	170	210	245	310	365	440	625
		Inverted	60	65	80	90	125	140	155	200	325
	N#2	Upright	-	170	200	243	297	383	485	-	-
Inverted		-	65	80	90	125	140	155	-	-	

Model		E2625	E2501	E1802	E1805	E1810	E1820	E1830	E1850	E18100
Fork End	ØA	10	12	20	25	35	50	Available on Request	Available on Request	Available on Request
	B	10	12	20	25	35	50			
	C	20	24	40	50	70	96			
	D	40	48	80	100	144	192			
	E	20	24	40	50	72	96			
	F	15	18	30	36	54	73			
	G	52	62	105	132	188	265			
	ØJ	18	20	34	42	60	82			
	L	M10 x 1.5	M12 x 1.75	M20 x 2.5	M24 x 3	M36 x 4	M48 x 5			
	M#1	Upright	114	148	194	248	302			
Inverted		59	68	104	128	182	230			
N#2	Upright	-	173	224	281	354	473			
	Inverted	-	68	104	128	182	230			

Model		E2625	E2501	E1802	E1805	E1810	E1820	E1830	E1850	E18100
Rod End	A	43	50	77	94	125	160	Available on Request	Available on Request	Available on Request
	ØB	10	12	20	25	35	50			
	C	15	18	27	32	42	60			
	ØD	29	34	53	64	82	112			
	F	-	23	40	48	60	68			
	ØG	19	22	35	42	58	75			
	H	9	10	16	20	25	35			
	J	7	8	13	17	21	30			
	K	17	19	32	36	50	65			
	L	M10 x 1.5	M12 x 1.75	M20 x 1.5	M24 x 2	M36 x 3	M45 x 3			
M#1	Upright	117	150	190	242	283	367			
	Inverted	62	70	100	122	163	197			
N#2	Upright	-	175	220	275	335	440			
	Inverted	-	70	100	122	163	197			

Note

1. M = For Machine Screw Jacks
2. N = For Ball Screw Jacks, Standard Lead only.

Features

- Protects the screw from dust and dirt
- Guards against moisture and corrosive contaminants
- Helps maintain the proper lubrication
- Boots are made of P.V.C. coated nylon with sewn construction. Other materials are available for applications involving high temperatures, highly corrosive atmospheres and other special conditions.



Boot Dimensions

Model	A	B	C	D	E
E2625-B	25	60	100	13	13
E2501-B	30	70	110	15	15
E1802-B	40	90	120	15	23
E1805-B	50	115	140	15	31
E1810-B	65	136	150	15	31
E1820-B	75	165	165	20	20
E1830-B	110	220	191	20	20
E1850-B	150	285	210	20	45
E18100-B	200	220	244	20	20

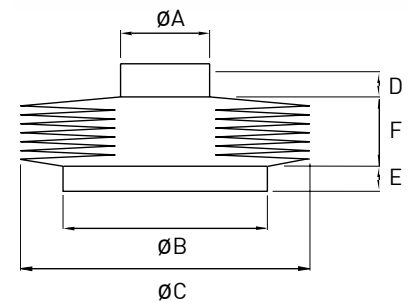

Model		E2625-B	E2501-B	E1802-B	E1805-B	E1810-B	E1820-B	E1830-B	E1850-B	E18100-B
F	Stroke 0 → 150	10	-	-	-	-	-	-	-	-
	Stroke 0 → 300	20	20	20	20	20	20	20	20	20
	Stroke 300 → 600	30	35	30	30	30	30	30	30	30
	Stroke 600 → 750	-	40	-	-	-	-	-	-	-
	Stroke 600 → 900	-	-	-	45	-	-	-	-	-
	Stroke 750 → 1000	-	60	-	-	-	-	-	-	-
	Stroke 600 → 1050	-	-	50	-	50	50	50	50	50
	Stroke 900 → 1050	-	60†	-	50	-	-	-	-	-
	Stroke 1000 → 1250	-	-	70	-	-	-	-	-	-
	Stroke 1050 → 1500	-	-	100†	70	70	70	70	70	70
	Stroke 1500 → 1800	-	-	-	95	-	90†	100†	-	-
	Stroke 1500 → 2000	-	-	-	-	105	-	-	-	-
	Stroke 1800 → 2100	-	-	-	110†	-	110†	-	-	-
	Stroke 2000 → 2500	-	-	-	-	120†	-	-	-	-
	Stroke 2100 → 2500	-	-	-	130†	-	-	-	-	-
Stroke 2500 → 3000	-	-	-	160†	-	-	-	-	-	

Note

1. F = Bellows boot minimum closed thickness
2. - = Not applicable
3. † = Control tapes fitted (approximately 20 mm increase to outer diameter).

Closed Heights

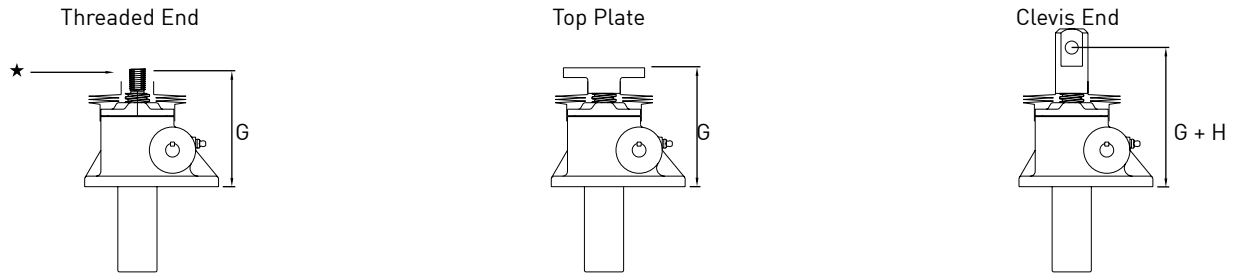

Standard Dimensions for all Upright Metric Machine Screw Jacks including Keyed

Model		E2625-B	E2501-B	E1802-B	E1805-B	E1810-B	E1820-B	E1830-B	E1850-B	E18100-B
G	Stroke 0 → 150	100	-	-	-	-	-	-	-	-
	Stroke 0 → 300	110	140	160	200	215	280	330	390	560
	Stroke 300 → 600	120	155	170	210	225	290	340	400	565
	Stroke 600 → 750	-	160	-	-	-	-	-	-	-
	Stroke 600 → 900	-	-	-	225	-	-	-	-	-
	Stroke 750 → 1000	-	180	-	-	-	-	-	-	-
	Stroke 600 → 1050	-	-	190	-	245	310	360	420	585
	Stroke 900 → 1050	-	-	-	230	-	-	-	-	-
	Stroke 1000 → 1250	-	180+	-	-	-	-	-	-	-
	Stroke 1050 → 1500	-	-	210	250	265	330	380	440	605
	Stroke 1500 → 1800	-	-	240+	275	-	350+	410+	-	-
	Stroke 1500 → 2000	-	-	-	-	300	-	-	-	-
	Stroke 1800 → 2100	-	-	-	290+	-	370+	-	-	-
	Stroke 2000 → 2500	-	-	-	-	315+	-	-	-	-
Stroke 2100 → 2500	-	-	-	310+	-	-	-	-	-	
Stroke 2500 → 3000	-	-	-	340+	-	-	-	-	-	
H	Extra Closed Height for Clevis	20	20	25	25	45	45	40	50	65

Standard Dimensions for all Upright Metric Anti-Backlash Screw Jacks including Keyed

Model		E4625-B	E4501-B	E4802-B	E4805-B	E4810-B	E4820-B	E4830-B	E4850-B	E48100-B
G	Stroke 0 → 150	105	-	-	-	-	-	-	-	-
	Stroke 0 → 300	115	140	160	200	215	280	345	415	585
	Stroke 300 → 600	120	155	170	210	225	290	355	425	585
	Stroke 600 → 750	-	160	-	-	-	-	-	-	-
	Stroke 600 → 900	-	-	-	225	-	-	-	-	-
	Stroke 750 → 1000	-	180	-	-	-	-	-	-	-
	Stroke 600 → 1050	-	-	190	-	245	310	375	445	600
	Stroke 900 → 1050	-	-	-	230	-	-	-	-	-
	Stroke 1000 → 1250	-	180+	-	-	-	-	-	-	-
	Stroke 1050 → 1500	-	-	210	250	265	330	395	465	620
	Stroke 1500 → 1800	-	-	240+	275	-	350+	425+	-	-
	Stroke 1500 → 2000	-	-	-	-	300	-	-	-	-
	Stroke 1800 → 2100	-	-	-	290+	-	370+	-	-	-
	Stroke 2000 → 2500	-	-	-	-	315+	-	-	-	-
Stroke 2100 → 2500	-	-	-	310+	-	-	-	-	-	
Stroke 2500 → 3000	-	-	-	340+	-	-	-	-	-	
H	Extra Closed Height for Clevis	20	20	25	25	45	45	40	50	65

Closed Heights

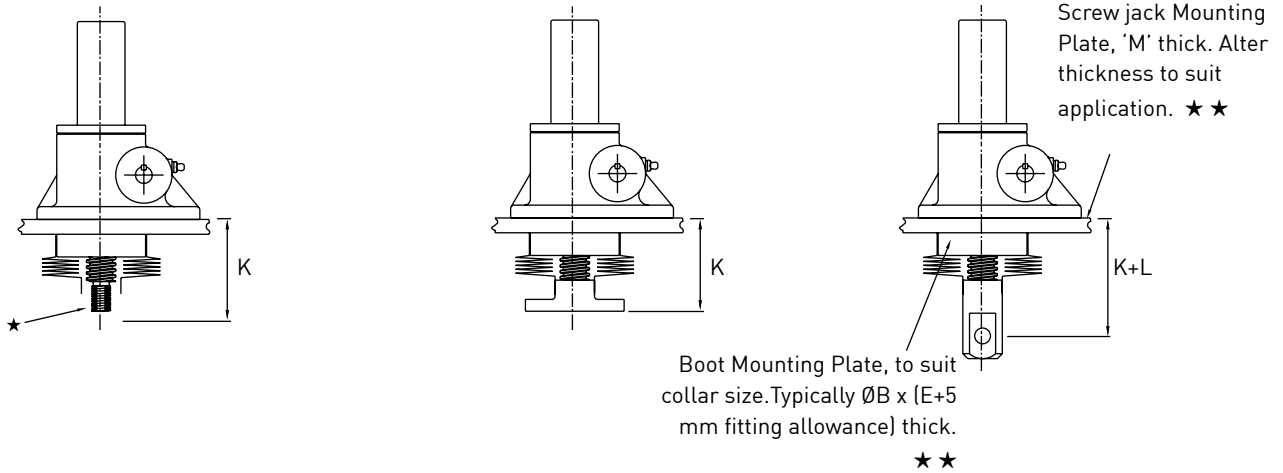

Standard Dimensions for all Inverted Metric Machine Screw Jacks including Anti-Backlash and Keyed

	Model	E2624-B	E2500-B	E1801-B	E1804-B	E1809-B	E1819-B	E1829-B	E1849-B	E18099-B
M	Mounting Plate	10	10	15	15	20	20	30	30	50
K	Stroke 0 → 150	70	-	-	-	-	-	-	-	-
	Stroke 0 → 300	80	85	105	120	130	135	165	215	260
	Stroke 300 → 600	90	100	115	130	140	145	175	225	260
	Stroke 600 → 750	-	105	-	-	-	-	-	-	-
	Stroke 600 → 900	-	-	-	145	-	-	-	-	-
	Stroke 750 → 1000	-	125	-	-	-	-	-	-	-
	Stroke 600 → 1050	-	-	135	-	160	165	195	245	280
	Stroke 900 → 1050	-	-	-	150	-	-	-	-	-
	Stroke 1000 → 1250	-	125†	-	-	-	-	-	-	-
	Stroke 1050 → 1500	-	-	155	170	180	185	215	265	300
	Stroke 1500 → 1800	-	-	185†	195	-	205†	245†	-	-
	Stroke 1500 → 2000	-	-	-	-	215	-	-	-	-
	Stroke 1800 → 2100	-	-	-	210†	-	225†	-	-	-
	Stroke 2000 → 2500	-	-	-	-	230†	-	-	-	-
Stroke 2100 → 2500	-	-	-	230†	-	-	-	-	-	
Stroke 2500 → 3000	-	-	-	260†	-	-	-	-	-	
L	Extra Closed Height for Clevis	20	20	25	25	45	45	40	50	65
p	Extra Closed Height for Keyed Anti-Backlash Units	4	6	4.5	9	10	19	13	33	115

Notes for all metric machine screw jacks with bellows boots

1. Supplied complete with a set of corrosion-resistant 'jubilee' clips (2) suitable for fitting over collar diameters.
2. † Control tapes are fitted (approximately 20 mm increase to outer diameter).
3. For horizontal installation exceeding 450 mm of travel, internal boot guides are recommended.
4. Customers with threaded end screw jacks must provide a fixing for the unattached collar (★).
5. Bellows boots for Rotating Screw Jacks consult Power Jacks Ltd.
6. For other sizes, raises, and materials please consult Power Jacks Ltd.
7. All dimensions in millimetres unless otherwise stated.
8. Dimensions subject to change without notice.
9. Screw Jack mounting plate and bellows boot mounting plate are usually all part of the customers superstructure (★ ★). For other options consult Power Jacks.

Features

- Protects the screw from dust and dirt
- Guards against moisture and corrosive contaminants
- Helps maintain the proper lubrication
- Boots are made of P.V.C. coated nylon with sewn construction. Other materials are available for applications involving high temperatures, highly corrosive atmospheres and other special conditions.



Boot Dimensions

Model	A	B	C	D	E
E28501-B	30	75	114	12	12
E3802-B	40	66	120	15	15
E3805-B	50	85	140	15	15
E3810-B	65	100	150	15	15
E3820-B	75	105	165	20	20
E3830-B	Available on Request				
E3860-B	Available on Request				

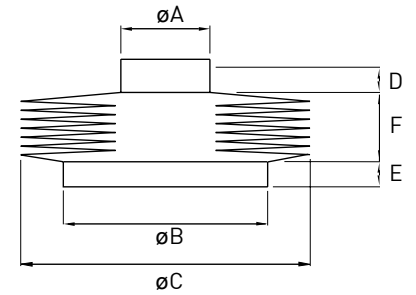

Model		E28501-B	E3802-B	E3805-B	E3810-B	E3820-B	E3830-B	E3860-B
F	Stroke 0 → 300	16	20	20	20	20	Available on Request	Available on Request
	Stroke 300 → 600	32	30	30	30	30		
	Stroke 600 → 900	-	-	45	-	-		
	Stroke 600 → 1050	56	50	-	50	50		
	Stroke 900 → 1050	-	-	50	-	-		
	Stroke 1050 → 1500	80	70	70	70	70		
	Stroke 1500 → 1800	-	100†	95	-	90†		
	Stroke 1500 → 2000	-	-	-	105	-		
	Stroke 1800 → 2100	-	-	110	-	110†		
	Stroke 2000 → 2500	-	-	-	120†	-		
	Stroke 2100 → 2500	-	-	130†	-	-		
Stroke 2500 → 3000	-	-	160†	-	-			

Note

1. F = Bellows boot minimum closed thickness
2. - = Not applicable consult Power Jacks Ltd
3. † = Control tapes fitted (approximately 20 mm increase to outer diameter).

Closed Heights

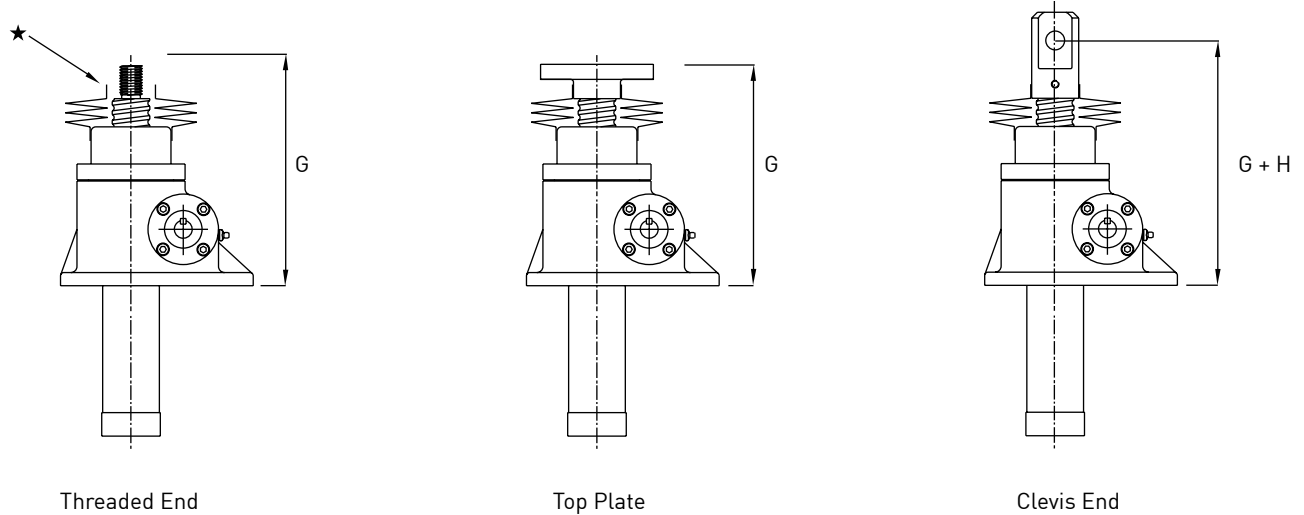

Standard Dimensions for all Upright Metric Ball Screw Jacks

Model	E28501-B	E3802-B	E38021-B	E3805-B	E38051-B	E3810-B	E38101-B	E3820-B	E38201-B	E3830-B	E3860-B
G	Stroke 0 → 150	-	-	-	-	-	-	-	-	-	-
	Stroke 0 → 300	166	180	200	230	270	255	285	323	361	-
	Stroke 300 → 600	182	190	210	240	280	265	295	333	371	-
	Stroke 600 → 900	-	-	-	255	295	-	-	-	-	-
	Stroke 600 → 1050	206	210	230	-	-	285	315	353	391	-
	Stroke 900 → 1050	-	-	-	260	300	-	-	-	-	-
	Stroke 1050 → 1500	230	230	250	280	320	305	335	373	411	-
	Stroke 1500 → 1800	-	260†	280†	305	345	-	-	393†	431†	-
	Stroke 1500 → 2000	-	-	-	-	-	340	370	-	-	-
	Stroke 1800 → 2100	-	-	-	320†	360†	-	-	413†	451†	-
	Stroke 2000 → 2500	-	-	-	-	-	355†	385†	-	-	-
	Stroke 2100 → 2500	-	-	-	340†	380†	-	-	-	-	-
Stroke 2500 → 3000	-	-	-	370†	410†	-	-	-	-	-	
H	Extra Closed Height for Clevis	20	25	25	25	25	45	45	45	45	-

Available on Request

Available on Request

Note

1. Supplied complete with a set of corrosion-resistant 'jubilee' clips (2) suitable for fitting over collar diameters
2. † Control tapes are fitted (approximately 20 mm increase to outer diameter).
3. For horizontal installation exceeding 450 mm of travel, internal boot guides are recommended.
4. Customers with threaded end Screw Jacks must provide a fixing for the unattached collar (★).
5. Bellows boots for Rotating Screw Jacks consult Power Jacks Ltd.
6. For other sizes, raises, and materials please consult Power Jacks Ltd.
7. All dimensions in millimetres unless otherwise stated.

Closed Heights

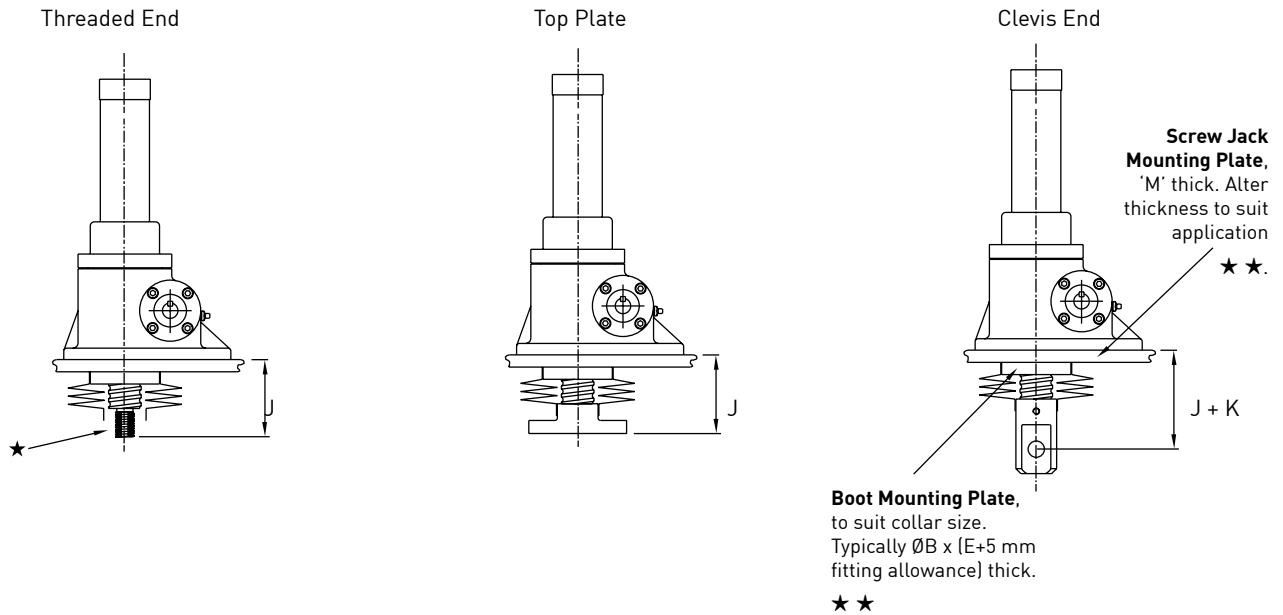

Standard Dimensions for all Inverted Metric Ball Screw Jacks

Model		E28501-B	E3801-B & E38011-B	E3804-B & E38041-B	E3809-B & E38091-B	E3819-B & E38191-B	E3829-B & E38291-B
M	Mounting Plate Thickness	10	15	15	20	20	30
J	Stroke 0 → 150	-	-	-	-	-	Available on Request
	Stroke 0 → 300	61	100	105	120	140	
	Raise 300 → 600	77	110	115	130	150	
	Stroke 600 → 900	-	-	130	-	-	
	Stroke 600 → 1050	101	130	-	150	170	
	Stroke 900 → 1050	-	-	135	-	-	
	Stroke 1050 → 1500	125	150	155	170	190	
	Stroke 1500 → 1800	-	180†	170	-	210†	
	Stroke 1500 → 2000	-	-	-	195	-	
	Stroke 1800 → 2100	-	-	185†	-	230†	
	Stroke 2000 → 2500	-	-	-	210†	-	
Stroke 2100 → 2500	-	-	205†	-	-		
Stroke 2500 → 3000	-	-	235†	-	-		
K	Extra Closed Height for Clevis	20	25	25	45	45	

Note

- Supplied complete with a set of corrosion-resistant 'jubilee' clips [2] suitable for fitting over collar diameters.
- † Control tapes are fitted (approximately 20 mm increase to outer diameter).
- For horizontal installation exceeding 450 mm of travel, internal boot guides are recommended.
- Customers with threaded end screw jacks must provide a fixing for the unattached collar (★).
- Bellows boots for rotating screw jacks consult Power Jacks Ltd.
- For other sizes, and materials please contact Power Jacks Ltd.
- All dimensions in millimetres unless otherwise stated.
- Dimensions subject to change without notice.
- Screw Jack mounting plate and bellows boot mounting plate are usually all part of the customers superstructure (★★). For other options consult Power Jacks.

End of Travel Proximity Sensors Sensor Kit

- Inductive Proximity Sensors as standard, others available on request.
- No contact so no wearing parts.
- 2 wire sensor for either Normally Closed (NC) or Normally Open (NO) switching.
- Sensor has rugged one-piece metal housing.
- Optical setting aid with 2 LED colour settings:- Red LED indicates just in sensing range. Yellow LED only indicates within 80% safe sensing range.
- M12 plug in connection for fast change-ability.
- M12 sockets available straight or angled with 5-m cable (other cable lengths available on request).
- Full 360° visibility for switching with 4 yellow LED's at 90° offset.
- Sensor kit includes - sensor, mounting ring, target ring and modification to screw jacks cover pipe.

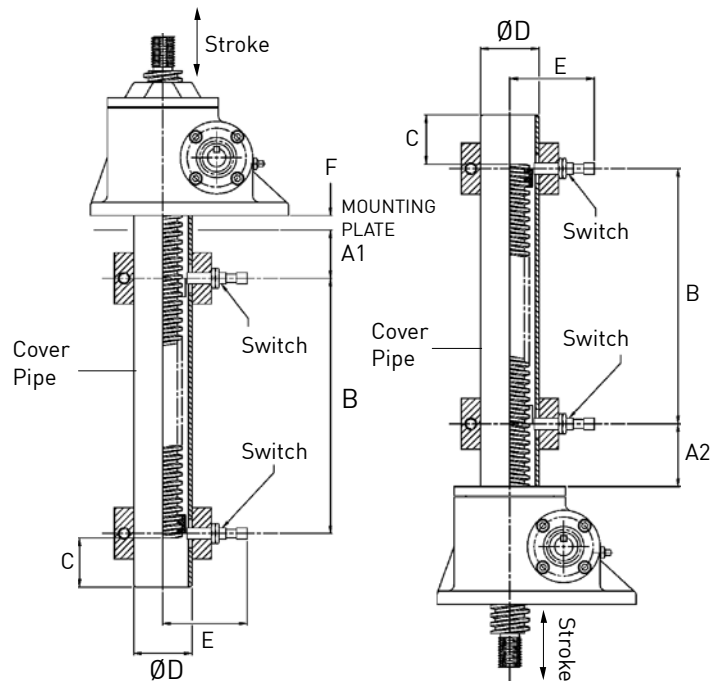

Metric Upright & Inverted Screw Jacks									
Capacity Rating (kN)	Switch Dia (mm)	A1 (mm)	A2 (mm)	B (mm)	C (mm)	D (Ømm)	E (mm) ±5	F (mm)	Switch Adjustment (mm)
25	12	50	40	Stroke + 15	40	48	83	15	±10
50	12	50	40	Stroke + 18	40	60	90	15	±10
100	18	50	40	Stroke + 24	45	73	103	20	±10
200	18	50	40	Stroke +24	45	89	110	20	±10

Note

1. All dimensions in mm unless otherwise stated.
2. Other sizes are available with cover pipe limit switches. Consult Power Jacks Ltd for advice.



End of Travel Electro-Mechanical Switches

The screw jacks can be fitted with electro-mechanical limit switches in a similar design. For dimensions please consult Power Jacks Ltd.



RLS-51 Rotary Limit Switch

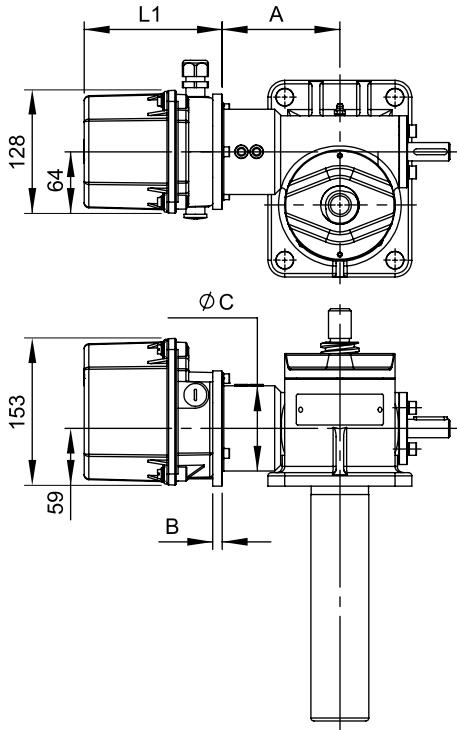

Rotary limit switches can be used as end of travel limit switches, with the option of intermediate switches as well. These units are mounted onto a screw jacks free worm shaft and offer an alternative where bottom pipe mounted limit switches are not possible e.g. rotating screw jacks. Up to 8 limit switches can be accommodated in one enclosure (IP66). Operating temperature -40°C → +80°C.

For full details on the RLS-51 limit switch refer to separate catalogue.

Metric Screw Jack Capacity (kN)								
Adapter Mounting	Std. Part	25			50			
		A	B	ØC	Std. Part	A	B	ØC
B5	x	-	-	-	x	-	-	-
B14	✓	117	10	70	✓	133	10	89

Metric Screw Jack Capacity (kN)								
Adapter Mounting	Std. Part	100			200			
		A	B	ØC	Std. Part	A	B	ØC
B5	✓	152	13	98	✓	174	13	125
B14	x	-	-	-	x	-	-	-

The mounting kit includes the flexible coupling and drive adapter.

Gear Size	Usable revs. selected	Usable revs. theoretical with 15° cam discs	Gear Ratio	1 rev. of the drive shaft - corresp. to an ang. motion of cam disc =°	Change - over contact reset rev. at driving shaft	Max drive speed (RPM)	Min drive shaft speed (only for change - over contact)	L1 (mm)			
								Limit Switches			
								2	4	6	8
1	4.1	4.16	4.285	84	0.00714	1000	0.67	132	132	157	157
	6.5	6.88	7.083	50.8	0.0118	1200	1.1				
	11	11.23	11.56	31.14	0.0193	1500	1.8				
2	17.5	17.84	18.361	19.6	0.0306	1800	2.9	132	132	157	182
	29	29.5	30.35	11.86	0.0505	1800	4.7				
	48	48.13	49.538	7.27	0.0825	1800	7.7				
3	75	76.45	78.678	4.57	0.131	1800	12.2	132	132	157	182
	125	126.39	130.054	2.77	0.2166	1800	20.2				
	205	206.26	212.272	1.69	0.3536	1800	33				
4	323	327.6	337.135	1.06	0.5616	1800	52	132	157	182	207
	540	541.5	557.284	0.65	0.9284	1800	87				
	880	883.8	909.59	0.4	1.515	1800	141				
5	1384	1403.7	1444.62	0.25	2.406	1800	224	132	157	182	207
	2288	2320.2	2387.96	0.15	3.978	1800	371				
	3735	3787.1	3897.58	0.09	6.493	1800	606				
6	5900	6014.77	6190.204	0.06	10.313	1800	*	157	157	182	207
	9800	9942.2	10232.407	0.04	17.047	1800	*				
	16000	16227.6	16701.17	0.02	27.824	1800	*				

Note

1. More than 8 contacts on request.
2. Dimensions with more than 8 contacts and with special executions, eg. potentiometer, on request.
3. RLS-51 B5 Flange thickness = 4mm.
4. Options available include Anti-condensation heaters, potentiometer, pulse transmitter, encoder, aluminum housing and VBG-70 STAGE technology.
5. Mounting kits available for all screw jacks. For those not listed, consult Power Jacks.

The SKA rotary limit switch is a compact 2-position limit switch designed for screw jack and linear actuator applications. For full details on the SKA limit switch refer to separate catalogue.

These limit switches are generally used for existing installations. For new applications, Power Jacks recommend the use of the RLS-51 Rotary Limit Switch.

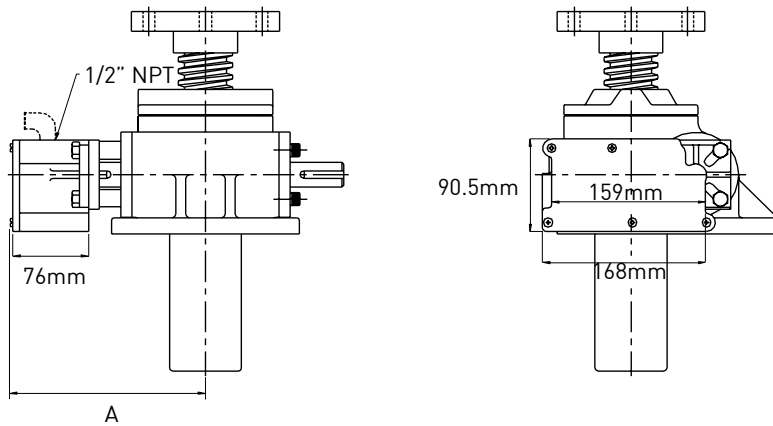

A (mm)	25kN	50kN	100kN	200kN	300kN	500kN	1000kN
Close Mount	N/A	137	180	195	223	252	290
Extended Mount (If Retro-fit)	176	199	224	234	274	313	374

Note

1. All dimensions are in millimetres (mm) unless otherwise stated.

Model No.	Max. Voltage		Max. Amps		Max. Worm Rev.	Max Raise	Max Allowable Drift	Notch Adjustment	
	AC	DC	AC	DC					
SKA-6000-A-10	250		15		1095	1095/TPU	24/TPU	1/TPU	
SKA-6000-A-20					2190	2190/TPU	48/TPU	2/TPU	
SKA-6000-A-40					4380	4380/TPU	96/TPU	4/TPU	
SKA-6000-B-10	480	125	15	0.5	750	750/TPU	29/TPU	1/TPU	
SKA-6000-B-20		250		0.25	1500	1500/TPU	57/TPU	2/TPU	
SKA-6000-B-40					3000	3000/TPU	115/TPU	4/TPU	
SKA-6000-C-10	120 240 480 800	115	15	0.80	675	675/TPU	38.5/TPU	1/TPU	
SKA-6000-C-20		230		0.40	1350	1350/TPU	77/TPU	2/TPU	
SKA-6000-C-40						2700	2700/TPU	154/TPU	4/TPU

Notes

1. Operating Temperaturee -29 °C → 65 °C
2. Enclosure IP65.

- Standard adapters for 25 kN - 300 kN metric machine screw and ball screw jacks
- Designed for standard IEC frame sizes
- Allows direct motor coupling on either side of the screw jack input shaft
- Complete with drive coupling and mounting hardware
- NEMA frame size versions available on request
- Adapters for other metric screw jacks and mounting arrangements available on request.

Note

- When direct coupling a motor to a screw jack, it is necessary to match motor power to screw jack load so the motor does not exceed the maximum power for the screw jack gear set.

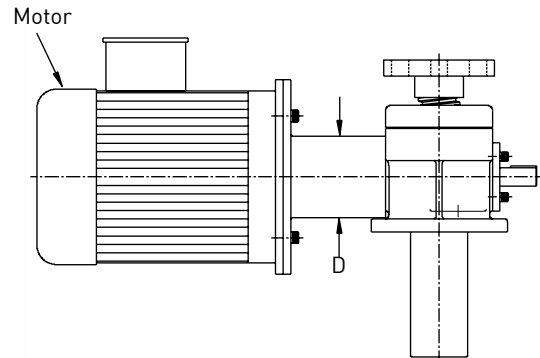
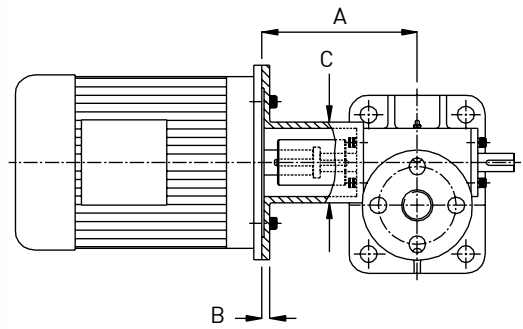

Motor Adapters		Capacity (kN)																					
		25				50				100				200				300					
Frame Size	Motor Mounting	Std. Part	A	B	C	Std. Part	A	B	C	Std. Part	A	B	C	D	Std. Part	A	B	C	D	Std. Part	A	B	C
71	B5	✓	145	14	80	x	-	-	-	x	-	-	-	-	x	-	-	-	-	x	-	-	-
	B14 C105	x	-	-	-	x	-	-	-	x	-	-	-	-	x	-	-	-	-	x	-	-	-
80	B5	✓	160	14	80	✓	187	14	100	x	-	-	-	-	x	-	-	-	-	x	-	-	-
	B14 C120	✓	145	14	80	x	-	-	-	x	-	-	-	-	x	-	-	-	-	x	-	-	-
90	B5	✓	160	14	80	✓	187	14	100	✓	212	14	110	98	✓	212	14	110	98	✓	250	14	120
	B14 C140	✓	145	14	80	x	-	-	-	✓	212	14	110	98	✓	212	14	110	98	✓	260	14	120
100	B5	✓	160	14	80	✓	207	14	100	✓	212	14	110	98	✓	212	14	110	98	✓	280	14	120
	B14 C160	✓	160	14	80	✓	187	14	100	✓	212	14	110	98	✓	212	14	110	98	✓	260	14	120
112	B5	x	-	-	-	✓	207	14	100	✓	212	14	110	98	✓	212	14	110	98	✓	280	14	120
	B14 C190	x	-	-	-	✓	187	14	100	✓	212	14	110	98	✓	212	14	110	98	✓	260	14	120
132	B5	x	-	-	-	✓	207	14	100	x	-	-	-	-	x	-	-	-	-	x	280	14	120
	B14 C200	x	-	-	-	✓	207	14	100	✓	212	14	110	98	✓	232	14	110	98	✓	280	14	120

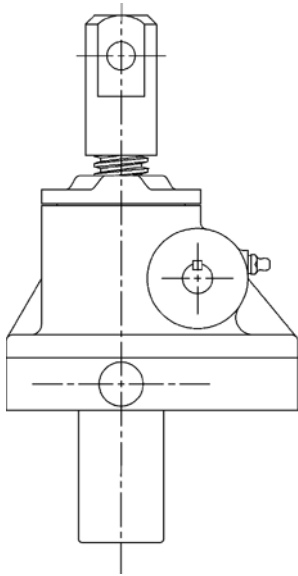

Type 1

Type 2

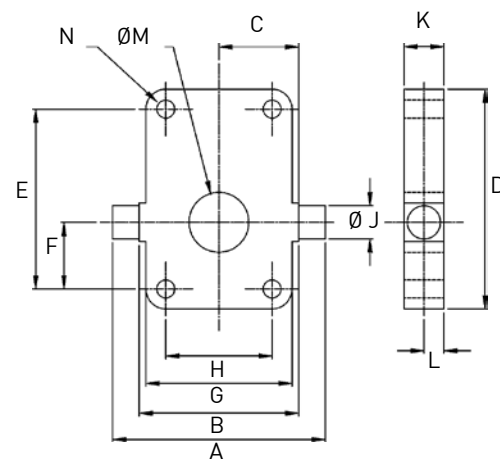
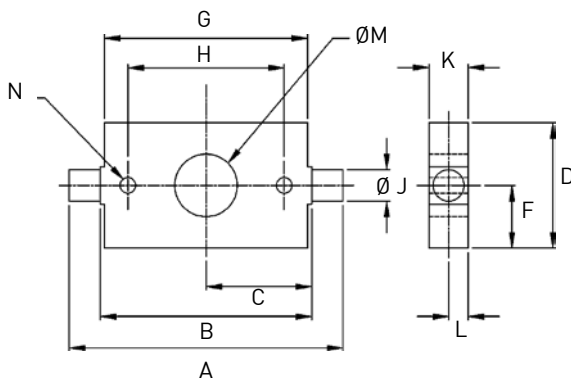

Capacity (kN)	Type	A	B	C	D	E	F	G	H	J	K	L	M	N	Weight (kg)
5	1	114	114	57	60	-	30	110	85	15	20	10	50	M8 (2)	1.24
10	1	175	135	67.5	80	-	40	130	100	20	25	12.5	58	M10 (2)	2.27
25	2	160	120	60	165	135	50	110	80	25	30	15	72	M12 (4)	3.27
50	2	200	160	80	205	170	57.5	150	115	35	40	20	95	M16 (4)	8.90
100	2	270	200	100	225	180	52.5	190	145	45	50	25	130	M20 (4)	15.57

Trunnion mounts bolt onto screw jack base plates.

Note

1. Trunnion mounts for other screw jack sizes are available on request
2. All dimensions in millimetres (mm) unless otherwise stated.

Stop Nut

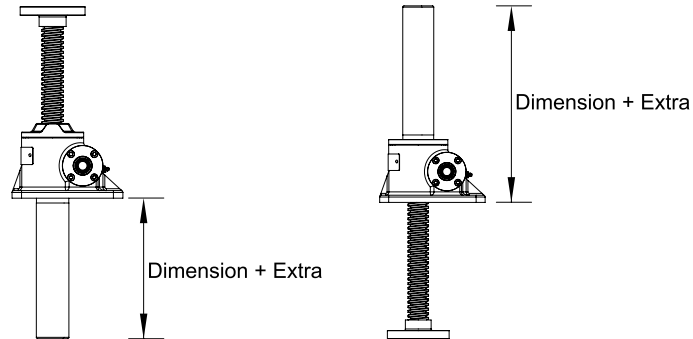

Machine Screw jack

Model	Extra (mm)	
	Upright	Inverted
E2525	On Request	
E2501	17	50
E1802	21	21
E1805	38	38
E1810	41	41
E1820	39	39
E1830	On Request	
E1850	On Request	
E18100	On Request	
E18150	On Request	
E18200	On Request	

Ball Screw Jack

Model	Extra (mm)	
	Upright	Inverted
E28501	On Request	
E3802	30	30
E3805	57	57
E3810	60	60
E3820	56	56
E3830	On Request	
E3860	On Request	

Hand Wheels

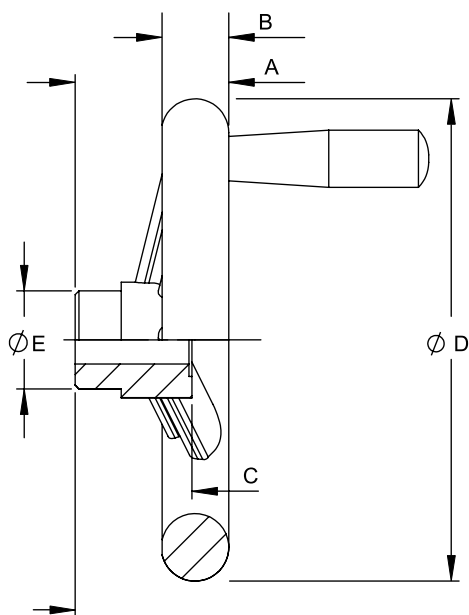

Model	A	B	C	ØD	ØE	H7 Bore
HW 005	40	14	36	98	24	Ø10
HW 010	50	22	38	157	32	Ø14
HW 025	56	24	43	198	40	Ø16
HW 050	56	24	43	198	40	Ø19
HW 100	66	30	44	247	49	Ø25

Notes:

1. Material: Polished aluminium casting and rotating handle
2. Bored and keyed to BS4235 Part 1
3. All dimensions in millimetres unless otherwise stated
4. Other types of hand wheels are available on request. Consult Power Jacks.

E-Series

7

ENGINEERING GUIDE

USEFUL PERFORMANCE & OPERATIONAL DETAIL FOR SCREW JACKS

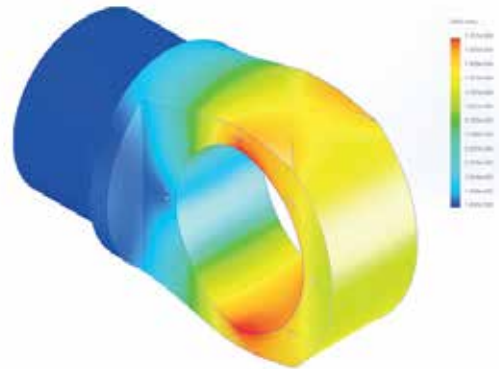
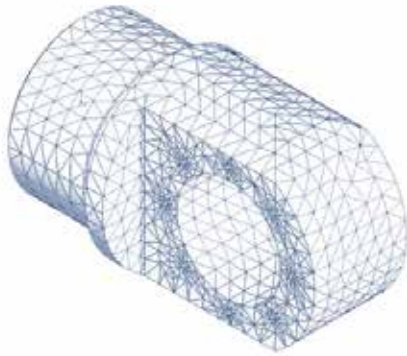
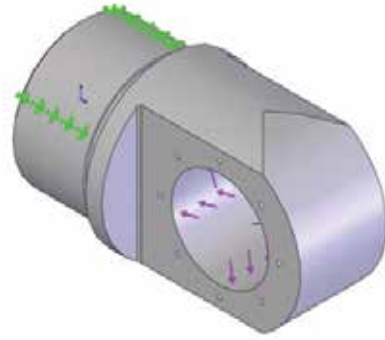

Important Notes

1. All charts are rated for industrial cargo with a safety factor of 3.5.
2. For human cargo a safety factor of 5 is recommended. To alter the permissible compressive load (WP) for human cargo multiply the load selected from the chart by 0.7 e.g. $W_{PHC} = W_P * 0.7$.

Column Length Correction Factors, F_{cb}

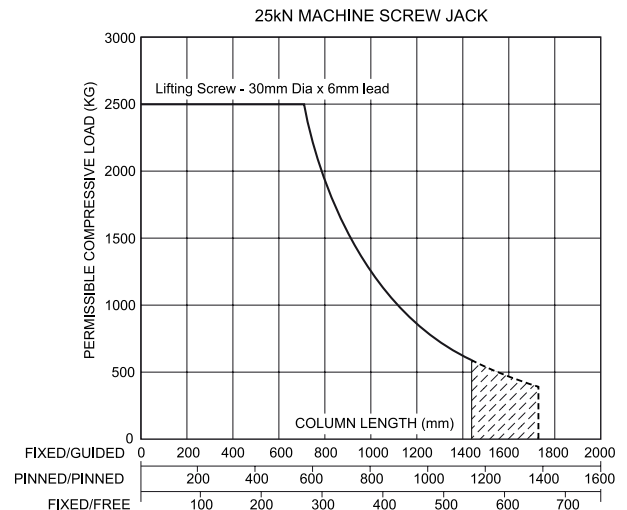
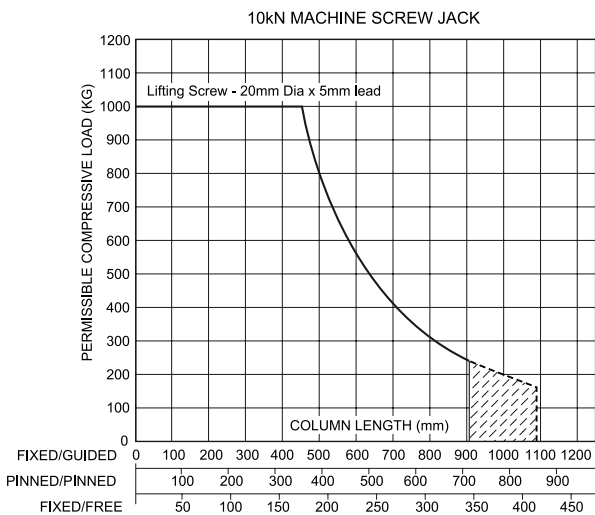
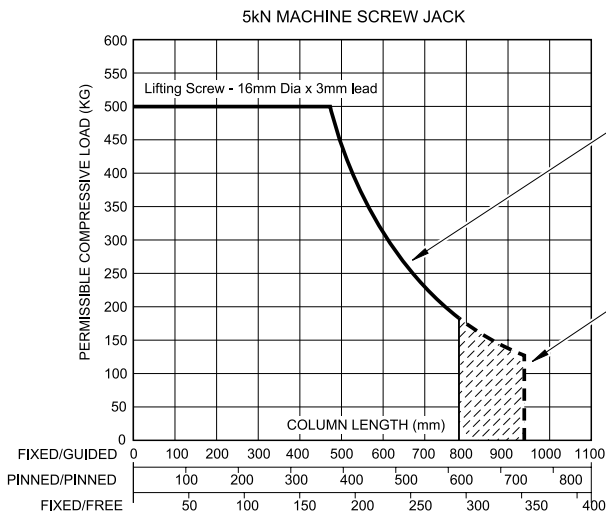
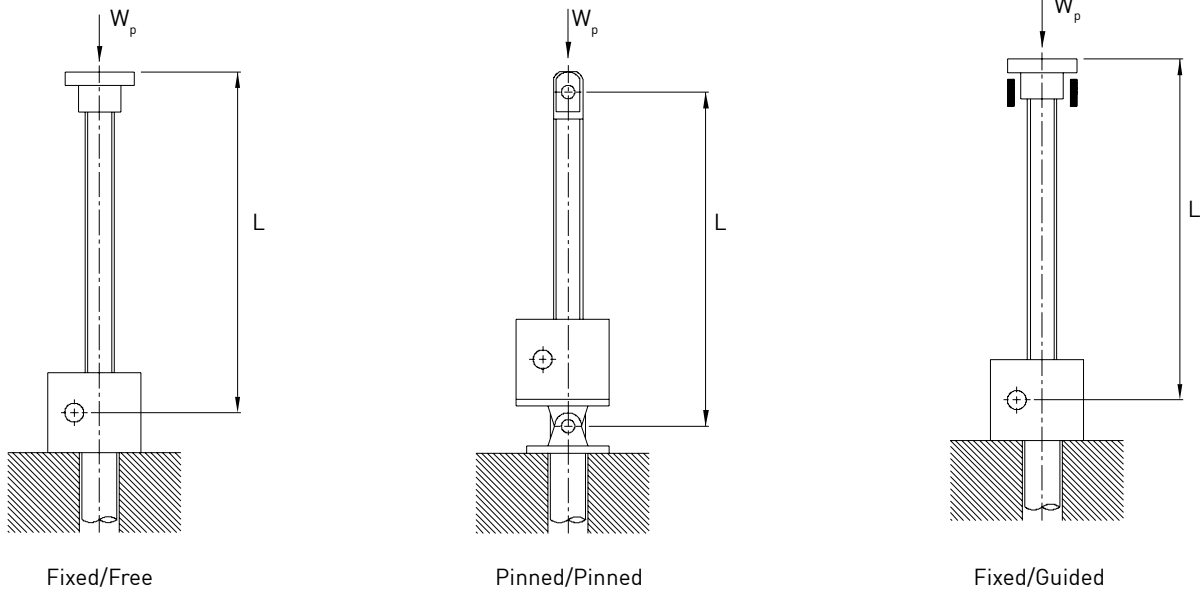

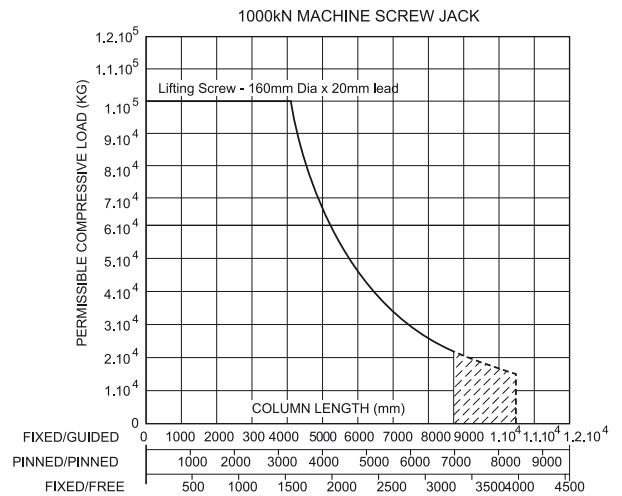
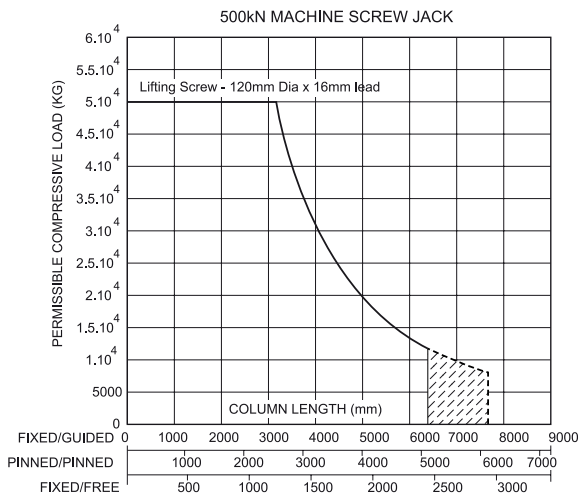
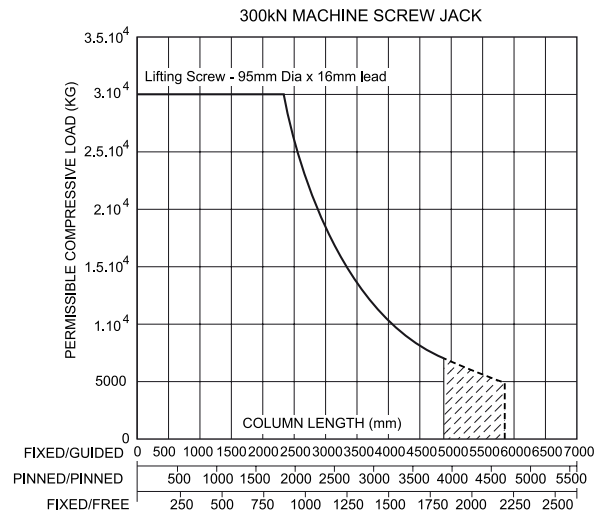
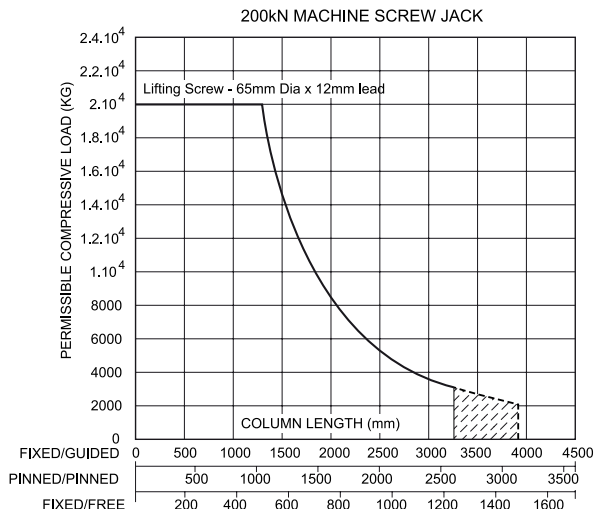
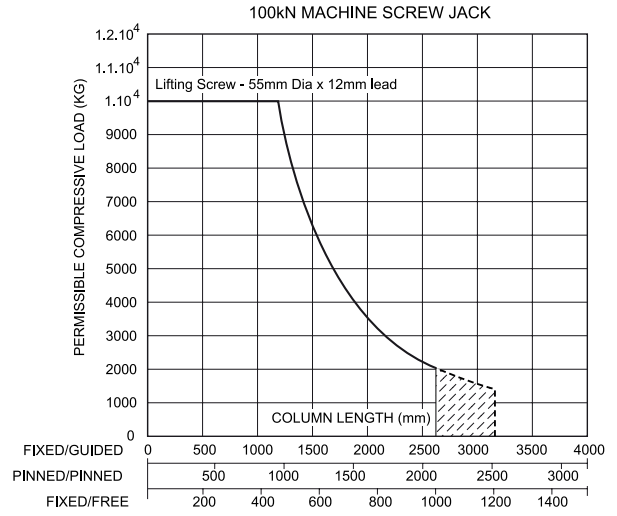
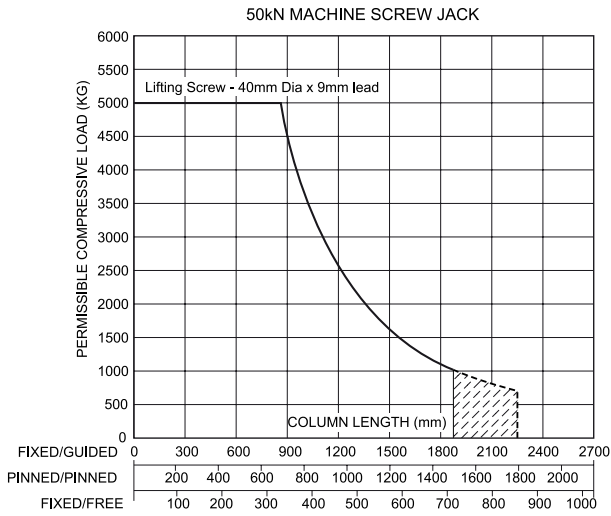

Note

1. Column end constraints based on A.I.S.C. recommended values
2. All screw jack column strength charts show a Euler buckling curve and three scales for the appropriate end condition for the application under analysis.

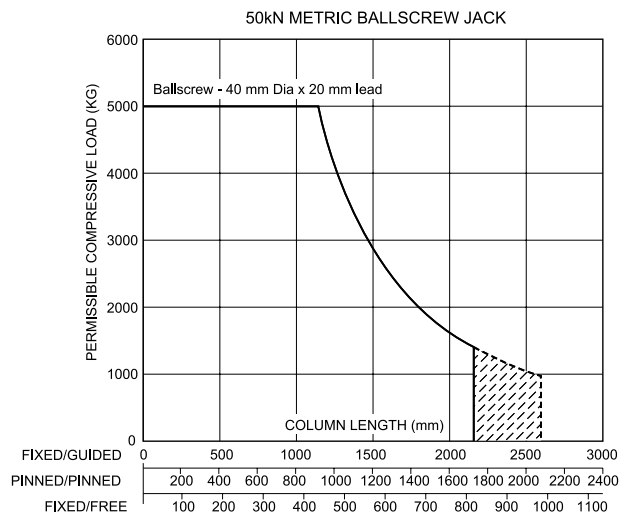
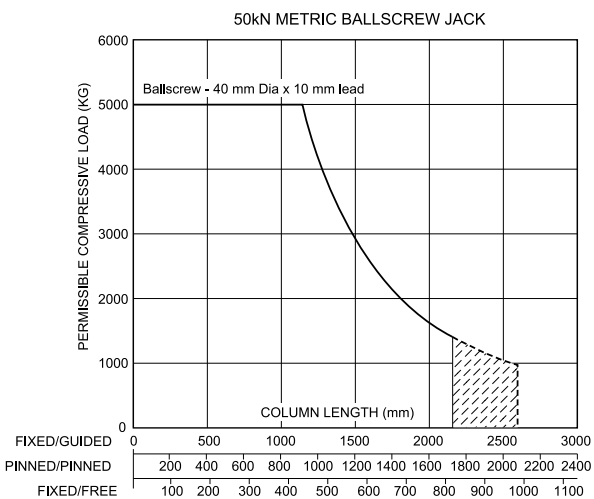
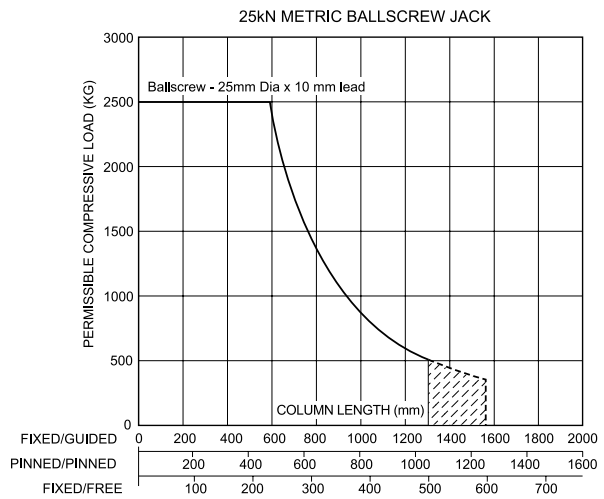
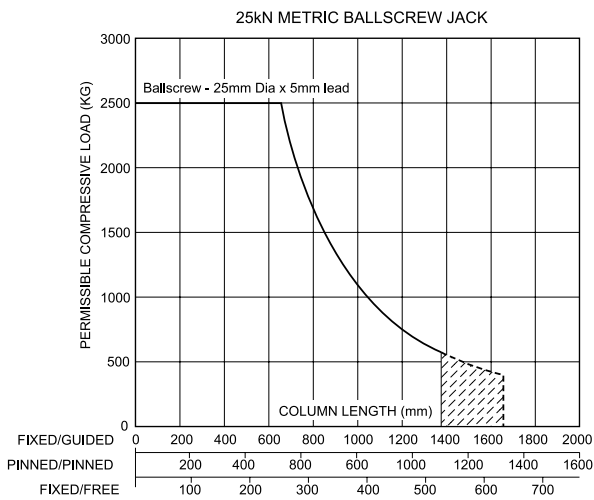
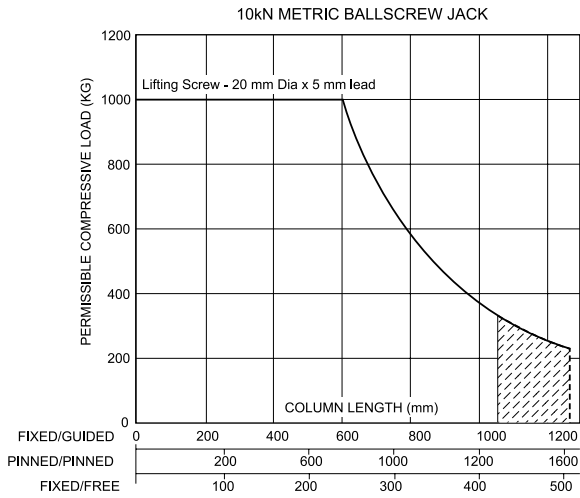

Critical Screw Speed Factors, F_{cs}

Fixed/Free, $F_{cs} = 0.15$

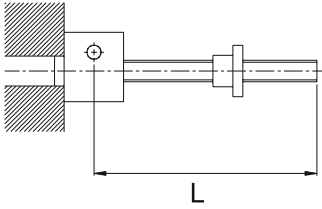

Fixed/Supported, $F_{cs} = 0.7$

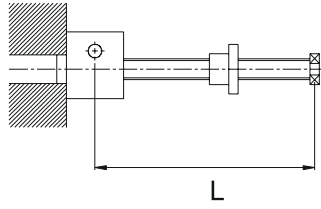

Fixed/Fixed, $F_{cs} = 1$

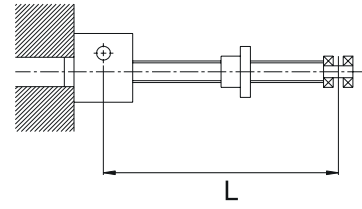

Metric Machine Screw Critical Screw Speed (Shaft Whirling)

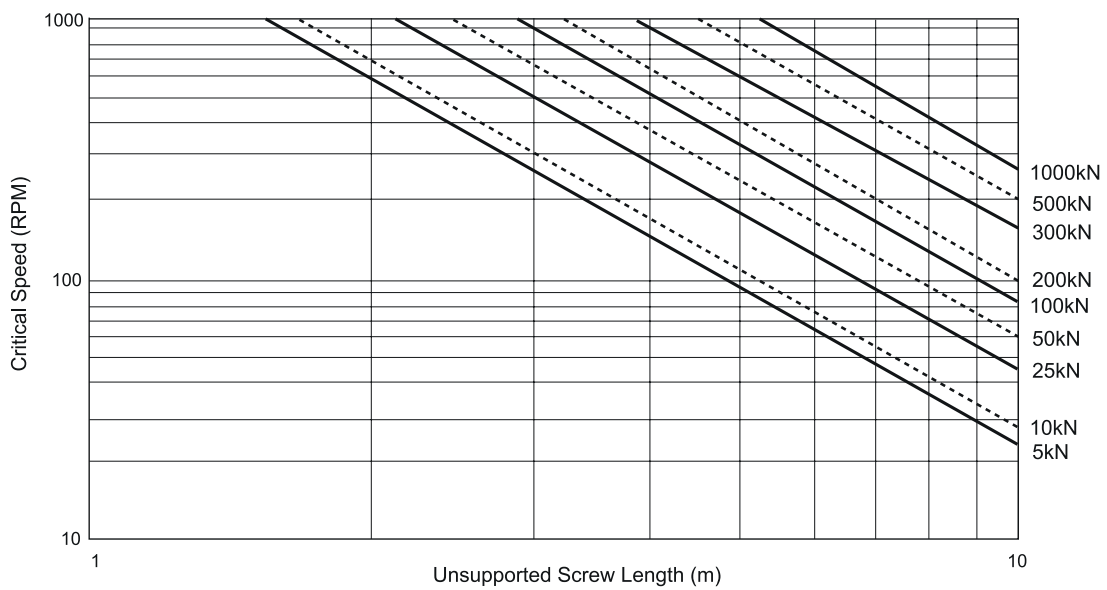

Based on both ends fixed and 80% of the critical speed.

Metric Ball Screw Critical Screw Speed (Shaft Whirling)

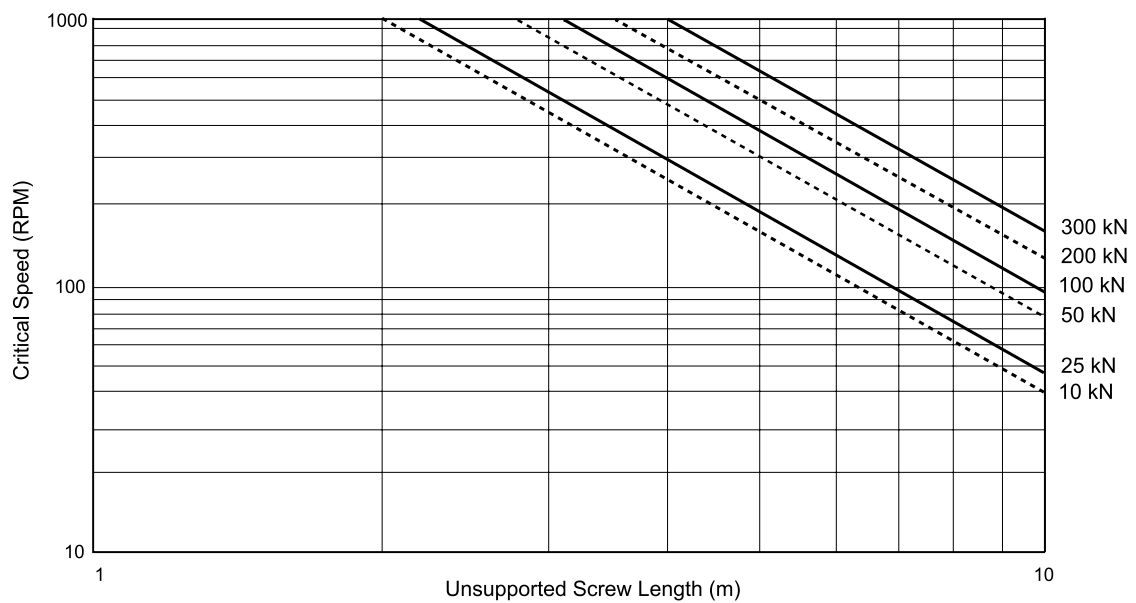

Based on both ends fixed and 80% of the critical speed.

The key torque is caused by the tendency of the lifting screw to rotate. It is a function of the screw lead, screw efficiency and the load. It is not affected by the screw jack unit gear ratio.

Note

The values below are given at rated load. For a smaller load reduce the key torque in direct proportion.

Machine Screw Jacks

Capacity (kN)	Screw Diam (mm)	Lead (mm)	Key Torque (Nm)
5	16	0.003	8
5	16	0.006	11
10	20	0.005	22
10	20	0.010	30
25	30	0.006	76
25	30	0.012	102
50	40	0.009	210
50	40	0.018	290
100	55	0.012	575
100	55	0.024	780
200	65	0.012	1300
200	65	0.024	1705
300	95	0.016	2805
300	95	0.032	3610
500	120	0.016	5645
500	120	0.032	6975
1000	160	0.020	14890
1000	160	0.040	18220

Ball Screw Jacks

Capacity (kN)	Screw Diam (mm)	Lead (mm)	Key Torque (Nm)
10	20	0.005	9
10	-	-	-
25	25	0.005	23
25	25	0.01	43
50	40	0.01	88
50	40	0.02	167
100	50	0.01	181
100	50	0.02	340
200	63	0.01	370
200	63	0.02	690
300	80	0.02	1030
500		On Request	

Maximum Jack Side Load Ratings with Full Jack Rated Load in Tension

Machine Screw Jacks

Metric Machine Screw Jack									
Capacity (kN)	5	10	25	50	100	200	300	500	1000
Max. Slide Load 300mm Offset (N)	100	150	540	1130	2900	3350	17500	37800	83400

Ball Screw Jacks

Metric Ball Screw Jack											
Capacity (kN)	10	25	25	50	50	100	100	200	200	300	500
Ball Screw Lead (mm)	5	5	10	10	20	10	20	10	20	20	*
Max. Slide Load 300mm Offset (N)	105	195	195	980	980	1570	1570	2060	2060	4340	*

*Consult Power Jacks.

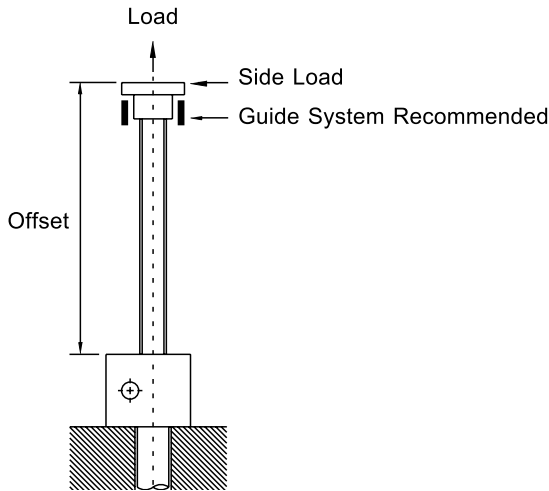

To calculate maximum side load for different raises for screw jacks in tension under full rated load use the following formula to modify the above tabulated values.

$$\text{Permissible Max. Side Load for Actual Offset} = \frac{\text{Max Side Load Rating Tabulated} \times \text{Stated Offset}}{\text{Actual Offset}}$$

Note
The correct units must be used

Important Notes

1. **These figures are for Screw Jacks in tension only.**
2. The figures given above are permissible side load ratings, however, we recommend that all side loads be carried by guides in your arrangement and not by the screw and nut.
3. Life of the lifting screw and nut will be adversely affected the more side load they see.
4. These figures are based on acceptable stresses in the lifting screw and not on lifting screw deflection.
5. For maximum side load ratings for screw jacks in compression consult Power Jacks Ltd.
6. For precise calculations for your application consult Power Jacks Ltd.

For applications where a screw jack is belt/chain driven, a calculation must be made to determine the radial force (F_R) and compared to the allowable radial load exerted on the worm shaft, that must not exceed those tabulated below. The values below are maximum values for the screw jacks at rated load regardless of worm speed or load direction and the radial load applied midway along the key of the worm shaft. For all applications the sprocket, gear etc. should be positioned as close as possible to the screw jack housing in order to reduce bearing loads and shaft stresses and to prolong life.

$$\text{Radial Force, } F_R = \frac{2000 \times T \times K}{D}$$

- Where
- F_R = Radial Load (N)
 - T = Torque applied to the screw jacks input shaft (Nm)
 - K = Factor from table below
 - D = PCD in mm of gear, sprocket

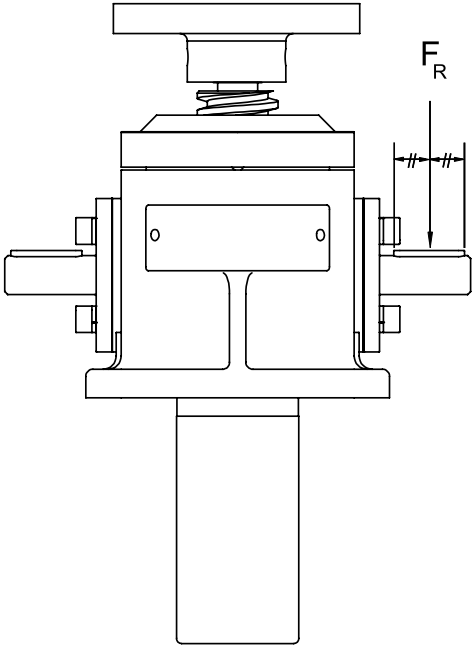

Transmission Element	Factor K
Chain sprocket	1
Gears (spur or helical pinion)	1.25
V-Belt pulley	1.5
Flatbelt pulley	2.0

Metric Machine Screw Jack				
Capacity (kN)	25	50	100	200
Radial Load (N)	440	1100	1200	1600

Metric Ball Screw Jack									
Capacity (kN)	5	10	25	50	100	200	300	500	1000
Radial Load (N)	180	325	380	740	1000	1600	2170	2190	2220

Machine Screw Jacks

Component	Normal Backlash
Lifting Screw and Nut	0.12mm → 0.2mm (0.005" → 0.008")
Load Bearings	0.00mm → 0.03mm (0.000" → 0.001")
Total	0.12mm → 0.23mm (0.005" → 0.009")

Note

1. The lifting screw backlash will increase during operation due to wear of threads in the nut
2. Axial play can be reduced by altering the load bearings preload to eliminate bearing play or by specifying a screw jack with the Anti-Backlash feature
3. For exact backlash ratings for an individual unit consult Power Jacks.

Anti-Backlash Option

This unit can be adjusted for screw thread and bearing clearances to a minimum of 0.025 mm (0.001"). Some clearances must be maintained to keep torque requirements within reason and to provide adequate space for a lubrication film to form.

Ball Screw Jacks

Component	Normal Backlash
Ball Track and Nut	0.05mm → 0.15mm (0.002" → 0.006")
Load Bearings	0.00mm → 0.03mm (0.000" → 0.003")
Total	0.05mm → 0.18mm (0.0002" → 0.007")

Note

1. For exact backlash ratings for an individual unit consult Power Jacks.
2. Ball nuts can be supplied with zero backlash or with adjustable backlash via a special twin nut assembly (twin nut assembly for rotating screw units only). Consult Power Jacks for details.
3. Altering the load bearings preload to eliminate bearing play can reduce axial play.
4. There is no Anti-Backlash nut feature for the gear sets of these screw jacks.

Pitch Deviation of Lifting Screw

Lifting Screw	Pitch Deviation
Machine Screw	0.05mm → 0.25mm per 300mm
Ball Screw	0.025mm → 0.050mm per 300mm (DIN Class 5.7)

Note

1. Pitch deviation is cumulative and **NOT** detrimental to the operation of the Screw Jack
2. The Lifting screws are manufactured from material with a straightness tolerance of 0.2 mm per metre
3. Pitch deviation is related to the cutting machines tolerance and the material used.

Metric Machine Screw Jacks

Stroke (mm)	5kN	10kN	25kN	50kN	100kN	200kN	300kN	500kN	1000kN
100	0.7	0.6	0.8	1.0	1.0	0.4	0.4	0.7	0.7
200	1.3	1.1	1.4	1.7	1.7	0.7	0.6	1.0	1.0
300	1.9	1.5	1.9	2.3	2.3	0.9	0.8	1.3	1.3
400	2.5	2.0	2.5	2.9	2.9	1.2	1.0	1.7	1.6
500	3.1	2.4	3.1	3.6	3.6	1.4	1.2	2.0	1.9
600	3.7	2.8	3.6	4.2	4.2	1.6	1.4	2.3	2.2
700	4.3	3.3	4.2	4.8	4.8	1.9	1.6	2.6	2.4
800	4.8	3.7	4.8	5.5	5.5	2.1	1.8	2.9	2.7
900	5.4	4.2	5.3	6.1	6.1	2.4	1.9	3.2	3.0
1000	6.0	4.6	5.9	6.7	6.7	2.6	2.1	3.6	3.3

Notes

1. Values quoted above are the maximum expected lateral movement for the given raise and screw jack model.
2. Does not allow for possible deflection due to side loads.
3. Lateral movements are for information only. For best results we recommend guides where possible.
4. Lateral movements will be reduced if the screw jack is fitted with secondary guides.
5. The above movements apply to machine screw jack only and not ball screw jacks. Permitting lateral movement on the ball screw jack under load will exert side thrust on the ball screw and ball nut and will be detrimental to the ball screw and nut life. Ball screw applications should be guided to ensure a minimum of lateral movement.
6. Where lateral movement is critical consult Power Jacks for exact values for the application.



How a Rotating Screw Jack Works

The rotation of the worm shaft causes the worm gear to rotate. For rotating screw jacks the lead screw is fixed to the worm gear and they rotate at the same speed. The lifting nut moves along the lead screw. As the worm gear turns, the friction forces on the screw thread act to turn the nut also. The greater the load on the screw jack unit, the greater the tendency of the nut to turn. If the nut turns with the screw, it will not raise the load. Therefore the nut needs to be fixed to a structure to prevent rotation. The restraining torque required for the structure, also known as the "lead screw key torque" can be found on P77 or requested from Power Jacks.

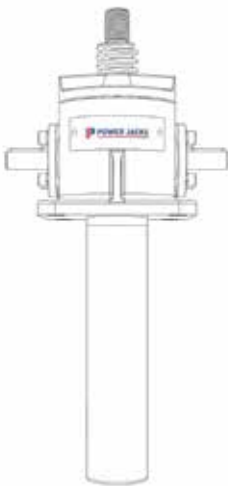

How a Translating Screw Jack Works

The rotation of the worm shaft causes the worm gear to rotate. For translating screw jacks the worm gear is threaded to accommodate the lead screw thread. The lead screw translates through the gear. As the worm gear turns, the friction forces on the screw thread act to turn the screw also. The greater the load on the screw jack unit, the greater the tendency of the screw to turn. If the screw turns with the nut (worm gear), it will not raise the load. In those cases where a single unit is used, and where the load cannot be restrained from turning, it is necessary to use a screw jack with an anti-rotation mechanism (keyed screw jack). Lead screw key torque (refer to P77 or request from Power Jacks) must be checked as excessively heavy unguided loads could break the Anti-rotation mechanism (key).



Anti-Backlash Screw Jack – When To Use

For reduced axial backlash of the lead screw in the screw jack select a model with the "Anti-Backlash" mechanism. This is typically used when the load direction changes from tension to compression and minimal axial backlash is required. This design is only available for translating screw jacks. It can be combined with Anti-Rotation mechanism as well.

Input Torque Required for a Screw Jack

The input torque for a single screw jack depends on the load, the worm gear ratio, type of screw (machine screw, ball screw or roller screw) and the pitch of the lead screw. Torque values are listed in the individual product specification charts based on capacity loads. For loads from 25% to 100% of screw jack model capacity, torque requirements are approximately proportional to the load.

Note

The input torque, as well as the efficiency and side load ratings, is the same for both translating screw and rotating screw jacks.

Maximum Input Power & Speed for a Screw Jack

The input power to the screw jacks should not exceed the power rating shown in the specifications table. Maximum input speed in rpm (revolutions per minute) to a screw jacks worm shaft should not exceed 1800 rpm for E-Series screw jacks.

Efficiency of a Screw Jack

Screw Jack model efficiencies are listed in the individual product specification charts.

Expected Life of a Screw Jack

The life expectancy of a screw jacks lead screw, bearings, nut and worm gear set varies considerably due to the extent of lubrication, abrasive or chemical action, overloading, excessive heat, improper maintenance, etc. For detailed life calculations, consult Power Jacks.

Screw Jack with Anti-Rotation (Keyed) Mechanism

This design is only available for translating screw jacks. If the structure/object connected to the lead screw is not prevented from rotating or the lead screw is not always in contact with the structure then a screw jack with an "Anti-Rotation" mechanism (keyed) should be used.

Standard Screw Jacks - How To Prevent The Load from Rotating

For multiple screw jack systems, fix the lead screw end fittings (e.g. top plate or clevis) to the common member being lifted by all the units. For single screw jack applications, bolt the lead screw end fitting (e.g. top plate or clevis) to the load and ensure the load is guided to prevent rotation.

A guided load is always recommended to ensure that the screw jack does not receive any side load and so guidance can be scaled suitably for the load without altering the screw jack design unnecessarily. Note that an external guidance system can provide a higher restraining "key" torque than compared to an anti-rotation mechanism in a screw jack.

Self-Locking of Screw Jacks

Screw Jacks with 24:1 or higher gear ratios are considered self-locking in most cases. Consult Power Jacks for a recommendation specific to your application.

All screw jacks with multi-start lifting screws are considered not to be self-locking.

All ball screw and roller screw jacks are considered not to be self-locking.

Screw Jacks considered not self-locking will require a brake or other holding device.

Shock Loads on a Screw Jack

Shock loads should be eliminated or reduced to a minimum, if they cannot be avoided, the screw jack model selected should be rated at twice the required static load.

For severe shock load applications, the load bearings can be replaced with heat-treated steel thrust rings which is an option available from Power Jacks. Note this will increase the input torque by approximately 100%.

Axial Backlash in a Screw Jack

Backlash in Standard Machine Screw Jacks

Machine screw jacks have backlash due not only to normal manufacturing tolerances, but to the fact that there must be some clearances to prevent binding and galling when the screw jack unit is under load. Usually, the axial backlash is not a problem unless the load on the screw jack unit changes between compression and tension. If a problem does exist, a unit with the anti-backlash feature should be considered.

Screw Jacks with the Anti-Backlash Device

The anti-backlash device reduces the axial backlash between the lead screw and nut assembly to a regulated minimum. As the backlash will increase as the lead screw thread on the gear wears the anti-backlash device can be adjusted to remove this normal condition.

How the Anti-Backlash Device Works

When the screw (1) is under a compression load, the bottom of its thread surfaces are supported by the top thread surfaces of the worm gear (2) at point (A). The anti-backlash nut (3), being pinned to the worm gear and floating on these pins and being adjusted downward by the shell cap, forces its bottom thread surfaces against the upper thread surfaces of the lifting screw at point (B). Thus, backlash between worm gear threads is reduced to a regulated minimum.

When wear occurs in the worm gear threads and on the load carrying surfaces of the lifting screw thread, the load carrying thickness of the worm gear thread will be reduced. This wear will create a gap at point (B) and provide backlash equal to the wear on the threads.

Under compression load, the lifting screw will no longer be in contact with the lower thread surface of the anti-backlash nut. Under this condition, backlash will be present when a tension load is applied. The anti-backlash feature can be maintained simply by adjusting the shell cap until the desired amount of backlash is achieved.

To avoid binding and excessive wear do not adjust lifting screw backlash to less than 0.025mm (0.001"). This will reduce the calculated separation (C) between the anti-backlash nut and worm gear and will reduce the backlash between the worm gear threads and the lifting screw to the desired minimum value.

When separation (C) has been reduced to zero, wear has taken place. Replace the worm gear (2) at this point. This feature acts as a built in safety device which can be used to provide wear indication for critical applications.

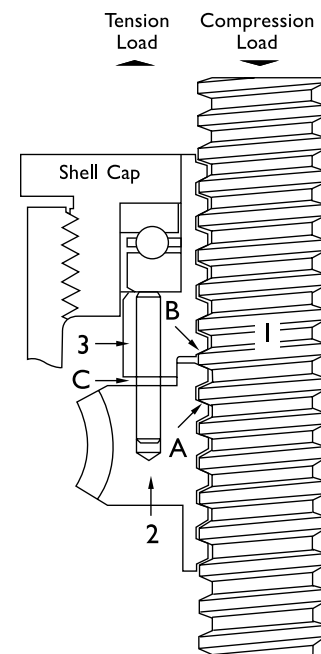

Column Strength of the Screw Jack

Column strength of a screw is determined by the relationship between the screw length and its diameter. For column strength charts consult product literature or Power Jacks.

Side Loads on a Screw Jack

Screw jacks are designed primarily to move and position loads and any side loads (loads not acting axially on lead screw) should be avoided. The units will withstand some side loads, depending on the diameter of the lifting screw and the extended length of the lifting screw. Where side loads are present, the loads should be guided and the guides, rather than the screw jacks, should take the side loads - particularly when long raises are involved. Even a small side load can exert great force on the housings and bearings and increase the operating torque and reduce the life expectancy.

Allowable Duty Cycle of Screw Jack

Because of the efficiency of conventional worm gear screw jacks, the duty cycle is intermittent at rated load. At reduced loading, the duty cycle may be increased. The high performance S-Series screw jacks have higher thermal efficiencies allowing generally 50% higher duty cycles than conventional worm gear screw jacks. For detailed analysis consult Power Jacks Ltd.

Maximum Operating Temperatures For E-Series Screw Jack

Normal operation at ambient temperatures of up to 90°C. Operations above 90°C will require special lubricants. For temperatures above 90°C, the life of even special lubricants is limited. Therefore consult Power Jacks on your application. For temperatures above 90°C, advise Power Jacks of full particulars of the duration of such temperatures. Power Jacks suggest that a lubricant manufacturer be consulted for type of grease and lubrication schedule. As a general rule, the screw jack unit should be shielded to keep ambient temperatures to 90°C or less.

Minimum Temperature For E-Series Screw Jacks

With the standard lubricant and materials of construction, the screw jacks are suitable for use at sustained temperatures of -20°C. Below -20°C, low temperature lubricant should be used and no shock loads are present. Power Jacks application engineers must be consulted in these instances for a recommendation. Screw Jacks with standard material of construction and lubrication may be safely stored at temperatures as low as -55°C.

Thermal / Heat Build-Up in a Screw Jack as it is operated

The duty cycle, the length of the screw, the magnitude of the load, and the efficiency of the screw jack all have a direct influence on the amount of heat generated within the screw jack. Long lifts can cause serious overheating. Note that high duty S-Series screw jacks have a higher thermal capacity than conventional worm gear screw jacks.

Screw Jacks to Pivot a Load

A screw jack can be built to pivot a load by two methods:

1. Double Clevis Screw Jack

The screw jack can be furnished with a clevis at both ends (commonly referred to as a double clevis screw jack). The bottom clevis is welded to the bottom end of an extra strong cover pipe, which is fitted to the base of the screw jack. This cover pipe still performs its primary function of encasing the lifting screw in its retracted portion.

2. Clevis - Trunnion Mounting

The screw jack is fitted with the pivot end fitting (e.g. Clevis) on the lead screw and a trunnion mount adapter is bolted to the screw jacks base plate.

The design of the structure in which these types of screw jacks are to be used must be constructed so that screw jack can pivot at both ends. Use only direct compression or tension loads, thereby eliminating side load conditions.

Corrosion Resistant Properties

Screw Jacks can be supplied with alternative materials and/or paint specifications for high corrosive areas. These options include stainless steel, chrome plating, electro-nickel plating, epoxy paint, etc. Check the unit specification is suitable before installation.

Using Screw Jacks within a Rigid Structure or Press

Power Jacks recommend that the screw jack selected has a greater capacity than the rated capacity of the press or of the load capacity of the structure. We also recommend that a torque clutch or similar device be used to prevent overloading of the screw jack unit. Unless these precautions are taken, it is possible to overload the screw jack without realising it.

Screw Jack Drift after Drive Motor is Switched Off

The screw jack will drift after the motor drive is switched off unless a brake of sufficient capacity is used to prevent it. The amount of drift will depend upon the load on the screw jack and the inertia of the rotor in the motor.

For machine screw jacks with no load, the amount of drift will depend upon the size and speed of the motor. For example, a 1500 RPM input directly connected to a screw jack without a load will give on average 35mm to 60mm of drift; a 1000 RPM input will give about 1/2 as much drift. Note that the drift varies as the square of the velocity (RPM). The drift of the screw jacks screw can be controlled by using a magnetic brake on the motor. Variations of drift will also be seen if the motor drives the screw jack via a reduction gearbox.

Screw Jacks Operation where Vibration is Present

Screw Jacks will operate in areas with vibration, however the vibration may cause the lead screw to “creep” or “inch” under load. For applications involving slight vibration, select the higher of the worm gear ratios. If considerable vibration is present, use a motor equipped with a magnetic brake, which will prevent the screw jack from creep and/or back-driving.

Use of Screw Jacks Fitted With Emergency Stop Disc

To prevent over travel of the lead screw, a stop disc or nut can be fitted to a screw jack that is hand operated. It should not be used as a full power stop.

Use of Screw Jacks Fitted With Emergency Stop Nut

For motor driven units, it is possible for the full capacity of the screw jack or even a greater force (depending on the power of the motor) to be applied against the stop. These stops are called “full power stop nuts”. They must only be used as an emergency device and if such a condition occurs, an assessment made to discover why it happened in order to carry out preventative action. If the full power stop nut is used at full load in an emergency it might be driven into the unit jamming so tightly that it must be disassembled in order to free it.

It is recommended that external stops are fitted where possible, however they must only be used as a last resort (Note - limit switches are one possible solution to constrain screw jack movement safely - consult Power Jacks for system advice). Under ideal conditions where a slip clutch or torque limiting device is used, a stop pin or stop nut may be used - but Power Jacks should be consulted.

Screw Jack System Arrangements

Perhaps the greatest single advantage of Power Jacks screw jacks is that they can be linked together mechanically, to lift, lower, move or position in unison. Typical mechanical system arrangements link 2, 4, 6 or 8 screw jacks together and are driven by one motor. As an alternative, screw jacks can be individually driven by electric motors and with suitable feedback devices, such as encoders, be synchronised electronically by a control system.

Connecting Screw Jacks in Series

The number of screw jacks that can be connected in series is limited by input torque requirements on the first worm shaft in the line. For the E-Series the torque on the worm shaft of the first screw jack should not exceed 300% of its rated full load torque (this does not include the 200kN screw jacks which are rated at 150%).

Efficiency of a Multiple Screw Jack System

In addition to individual device efficiencies, the efficiency of the screw jack arrangement must be taken into consideration. The arrangement efficiency allows for misalignment due to slight deformation of the structure under load, for the losses in couplings, bearings, and for a normal amount of misalignment in positioning the screw jacks and gearboxes. For efficiency values consult Power Jacks product literature or engineers.

Number of Screw Jacks in System	2	3	4	6-8
Jacking System Efficiency	0.95	0.90	0.85	0.80

Screw Jack Fitted with 3rd Party Accessories

If your screw jack is fitted with a device not manufactured by Power Jacks then please consult the provided manual for this device.

Installation and Maintenance Tips

The following installation and maintenance tips are for the E-Series, Metric machine screw and ball screw jacks models. General care should be taken to ensure that equipment is sufficient to handle the load.

1. The structure on which the screw jack unit is mounted should have ample strength to carry the maximum load, and be rigid enough to prevent undue deflection or distortion of the screw jack unit supporting members.
2. It is essential that the screw jack be carefully aligned during installation so that the lifting screws are vertically true and the connecting shafts are exactly in line with the worm shafts. After the screw jack, shafting, and gear boxes are coupled together, it should be possible to turn the main drive shaft by hand. If there are no signs of binding or misalignment, the jacking system is then ready for normal operation.
3. The screw jack should have a greater stroke than is needed in the screw jack installation. If it is necessary to operate the screw jack at the extreme limits of travel, it should be done with caution.

CAUTION: Do not allow screw travel below catalogue closed height of the screw jack or serious damage to internal mechanism may result. Refer to table specifications for closed height of respective units.

4. The input power should not exceed the power rating shown in the specification table. Maximum RPM should not exceed 1800.
5. The lifting screw should not be permitted to accumulate dust and grit on the threads. If possible, lifting screws should be returned to closed position when not in use.
6. The ball screws in the ball screw jacks should be checked periodically for excessive backlash and spalling of raceways. A periodic check of backlash of the lifting screw thread is recommended to check wear of the worm gear internal threads on the machine screw jack models. Backlash in excess of 50% of the thread thickness indicates the need to replace the worm gear.
7. Unless otherwise specified, screw jacks are shipped packed with grease which should be sufficient for one month of normal operation. For normal operation, the screw jacks should be lubricated about once a month, using one of the following extreme pressure greases or their equivalent:

Shell	Gadus S2V220AC2 (Alvania WR2)
BP	Energrease LC2
Castrol	Spheerol EPL2
Mobil	Mobilux EP2

For severe conditions, the screw jacks should be lubricated more frequently, using one of the above greases (daily to weekly depending on conditions). If duty is heavy, an automatic lubrication system is strongly recommended. If ambient temperatures exceed 90°C (194°F) consult Power Jacks.

8. On ball screw jack applications, periodically lubricate the exposed ball screw grooves with a cloth dampened with a good grade 10W30 oil for most applications. An instrument grade oil should be used in dirty and heavy duty environments, and bearing grease for environments at extremely high temperatures. Extreme temperature and other environmental conditions should be referred to Power Jacks for recommended lubricating procedures.

CAUTION: Where ball screws are not protected from airborne dirt, dust, etc., bellows boots should be used. Inspect frequently at regular intervals to be certain a lubricating film is present. Ball screws should never be run dry.

9. Due to the high efficiency of the ball screw jack design, a brake must be used in conjunction with motor selected to position the screw jack.

PRECISION SCREW JACKS . ELECTRIC LINEAR ACTUATORS .
PLANETARY ROLLER SCREWS . SPIRAL BEVEL GEARBOXES .

Power Jacks are an industry leader in the manufacture of quality industrial lifting,
positioning, material handling and power transmission equipment.

Our products are supplied globally to most industry sectors including nuclear, water,
oil & gas, chemical, defence, steel, aluminium, automotive and others.

DESIGN WITH POWER

Power Jacks Ltd
Balmacassie Commercial Park
Ellon, AB41 8BX
Scotland (UK)
Tel: +44 (0)1358 285100
www.powerjacks.com
sales@powerjacks.com

PJ-SJB-E-EN-02-5

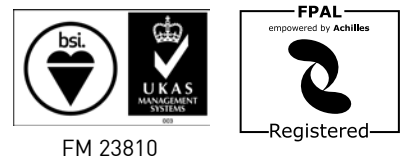

All information in this document is subject to change without notice.
All rights reserved by Power Jacks Limited. May not be copied in whole or in part.
©Power Jacks Limited 2014, Aberdeenshire, Scotland, United Kingdom