

Screw jacks SJ Series

Screw jacks SJ Series with travelling screw (Mod.A) STRUCTURAL ELEMENTS

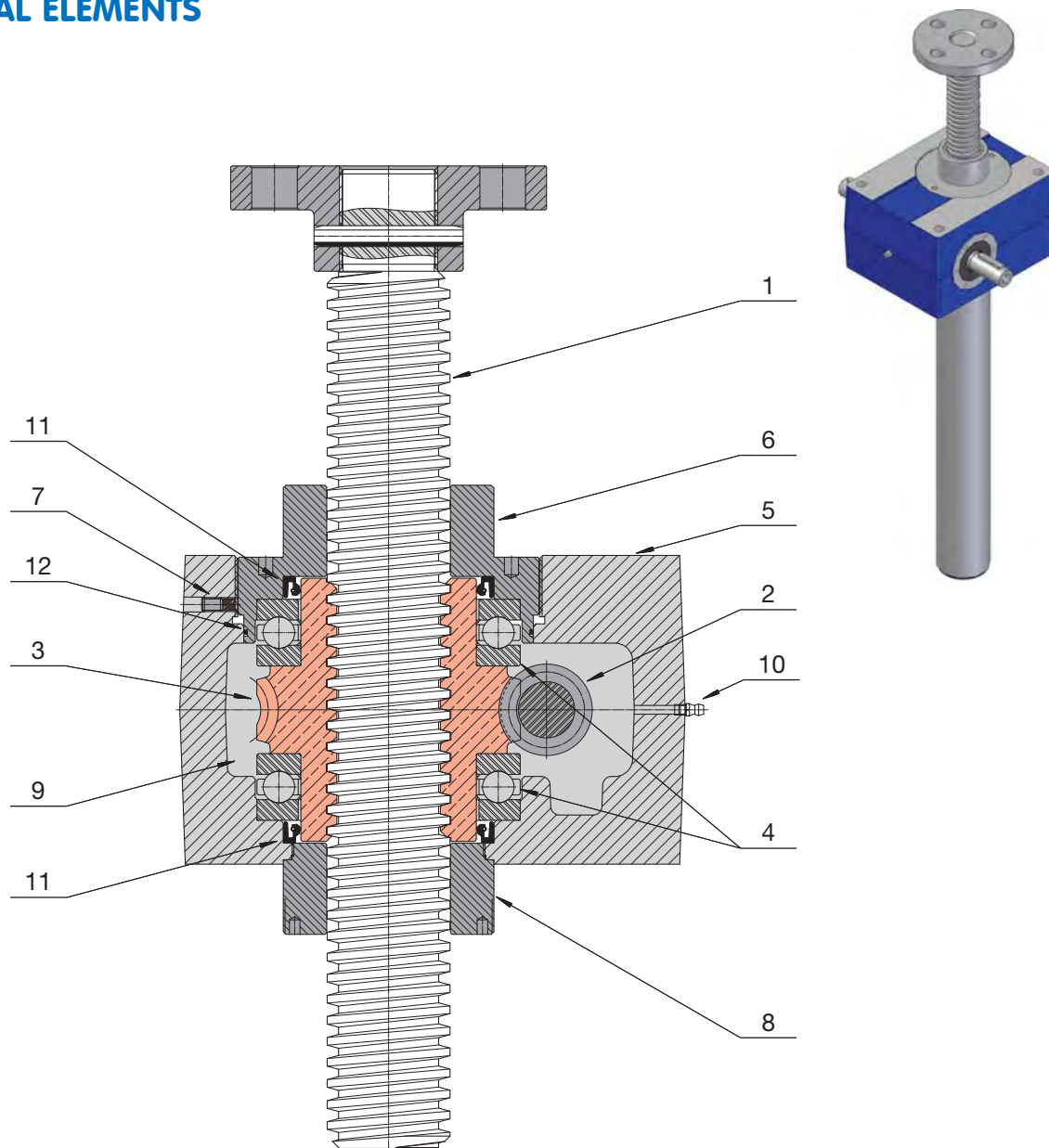

- 1 - acme screw in steel C 43 (UNI 7847), rolled or whirled thread
- 2 - worm shaft with true involute, ground worm profile ZI (UNI 4760), made in steel, case-hardened
- 3 - bronze wormwheel with internal nut, toothing with true involute profile ZI (UNI 4760)
- 4 - thrust ball bearing for high load capacity
- 5 - monoblock gear box
- 6 - threaded cover with guide for acme screw; may be used as a spigot diameter
- 7 - grub screw which prevents the threaded cover unscrewing
- 8 - guide for acme screw; may be used as a spigot diameter
- 9 - long-life synthetic grease lubricated worm gearbox
- 10 - grease nipple
- 11 - radial lubricant seal
- 12 - O-Ring as lubricant seal

Screw jacks SJ Series

Screw jacks SJ Series with travelling nut (Mod.B) STRUCTURAL ELEMENTS

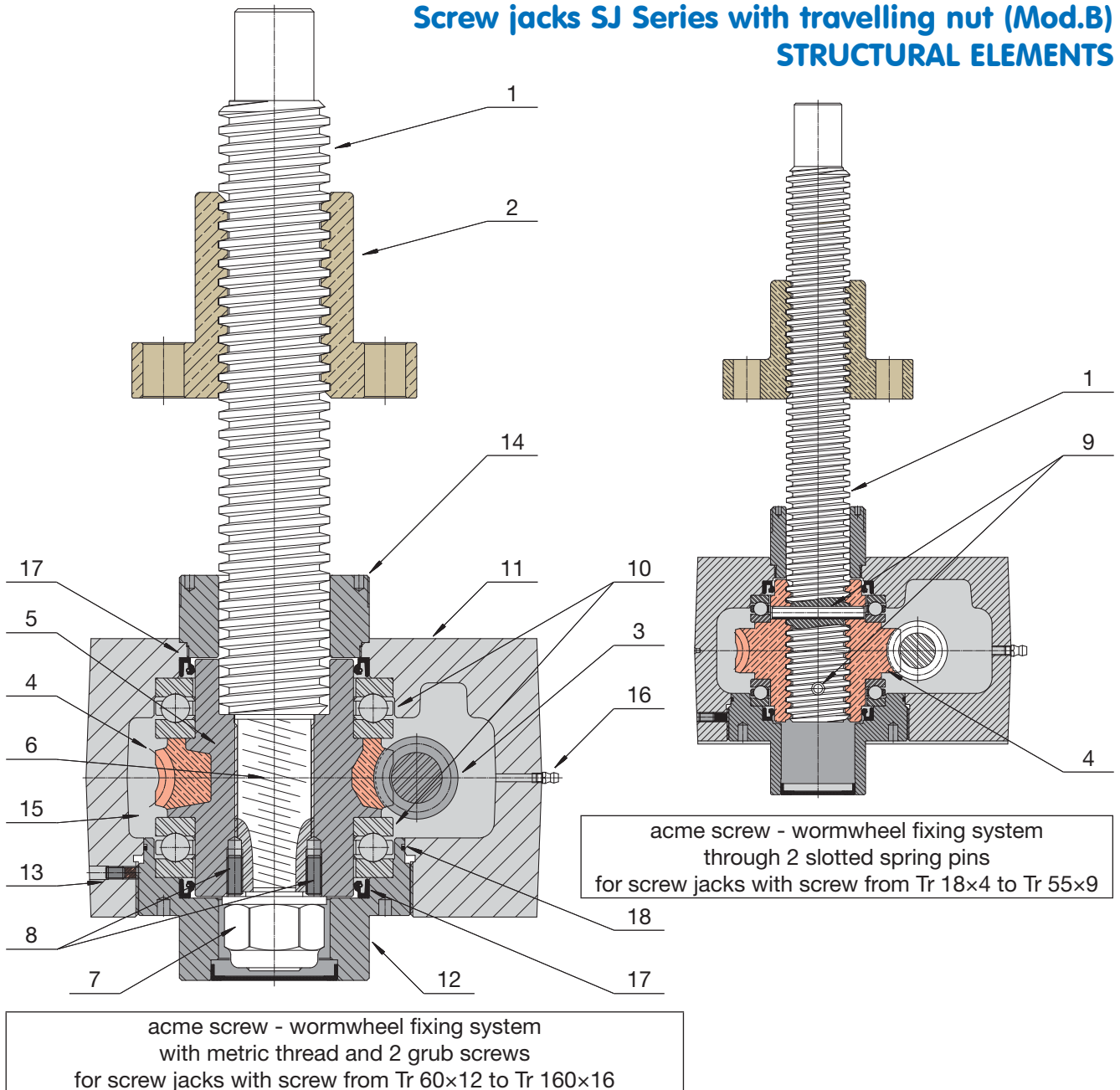

- 1 - acme screw in steel C 43 (UNI 7847), whirled thread
- 2 - bronze travelling nut with flange
- 3 - worm shaft with true involute, ground worm profile ZI (UNI 4760), made in steel, case-hardened
- 4 - bronze wormwheel with true involute profile ZI (UNI 4760)
- 5 - cast iron support of the wormwheel bronze rim
- 6 - acme screw fixed to the wormwheel through LEFT-HAND (for push load) or RIGHT-HAND (for pull load) metric thread
- 7 - lock nut with the opposite direction metric thread to ensure safe acme screw fixing
- 8 - acme screw – wormwheel pins against unscrewing
- 9 - slotted spring pin
- 10 - thrust ball bearing for high load capacity
- 11 - monoblock gear box
- 12 - threaded cover with guide for acme screw; may be used as a spigot diameter
- 13 - grub screw which prevents the threaded cover unscrewing
- 14 - guide for acme screw; may be used as a spigot diameter
- 15 - long-life synthetic grease lubricated worm gearbox
- 16 - grease nipple
- 17 - radial lubricant seal
- 18 - O-Ring as lubricant seal

Screw jacks SJ Series

Screw jacks SJ Series with 1-start acme screw TECHNICAL SPECIFICATIONS

SCREW JACK SIZE		SJ 5	SJ 10	SJ 25	SJ 50	SJ 100	SJ 150	SJ 200	
Load capacity [kN], (push - pull)		5	10	25	50	100	150	200	
1-start acme screw		Tr 18x4	Tr 22x5	Tr 30x6	Tr 40x7	Tr 55x9	Tr 60x12	Tr 70x12	
Worm gear centre distance [mm]		25	30	50	63	63	80	90	
Available ratio	RH	1 : 4 (5 : 20)	—	—	—	—	—	—	
	RV	1 : 6.25(4 : 25)	1 : 4 (4 : 16)	1 : 6 (4 : 24)	1 : 7 (4 : 28)	1 : 7 (4 : 28)	1 : 8 (4 : 32)	1 : 7 (4 : 28)	
	RN	1 : 12.5(2 : 25)	1 : 16 (2 : 32)	1 : 18 (2 : 36)	1 : 14 (2 : 28)	1 : 14 (2 : 28)	1 : 24	—	
	RL	1 : 25	1 : 24	1 : 24	1 : 28	1 : 28	1 : 32	1 : 28	
Stroke [mm] for 1 input shaft revolution	Ratio	RH1	1	—	—	—	—	—	
		RV1	0.64	1.25	1	1	1.28	1.5	1.71
		RN1	0.32	0.31	0.33	0.5	0.64	0.5	—
		RL1	0.16	0.21	0.25	0.25	0.32	0.375	0.43
Starting efficiency	Ratio	RH1	0.25	—	—	—	—	—	
		RV1	0.25	0.26	0.20	0.18	0.20	0.20	0.19
		RN1	0.21	0.20	0.16	0.15	0.17	0.13	—
		RL1	0.16	0.16	0.13	0.11	0.13	0.12	0.12
Running efficiency at 1500 rpm ⁽¹⁾	Ratio	RH1	0.35	—	—	—	—	—	
		RV1	0.34	0.36	0.34	0.32	0.33	0.36	0.36
		RN1	0.29	0.28	0.27	0.28	0.29	0.29	—
		RL1	0.25	0.25	0.25	0.23	0.24	0.26	0.25
Starting torque on input shaft at max. load [Nm]	Ratio	RH1	3.8	—	—	—	—	—	
		RV1	2.5	9	20	44	113	174	325
		RN1	1.7	3.5	8.3	25	68	83	—
		RL1	1	2.5	7.6	18	46	69	125
Max. permissible operating power [kW] ⁽²⁾	Ratio	RH1	0.40	—	—	—	—	—	
		RV1	0.40	0.60	1.2	2.4	2.5	3	4
		RN1	0.20	0.30	0.7	1.7	1.8	2.6	—
		RL1	0.17	0.25	0.6	1.2	1.2	2.3	3.2
Reactive torque on acme screw (nut) required at max. load [Nm]		8	20	65	165	460	800	1 200	
Gear box material		casting in aluminium alloy EN 1706 - AC-AISi10Mg T6			casting in cast iron EN-GJL-250 (UNI EN 1561)				
Mass of screw jack without acme screw [kg]		1.5	2.3	10.4	25	35	55	75	
Mass for every 100 mm of acme screw [kg]		0.16	0.23	0.45	0.8	1.6	1.8	2.5	

⁽¹⁾ - efficiency figures at different input speed on page 55

⁽²⁾ - THERMAL limit, referred to work with max. duty cycle 30 % over 10 min time period (20 % over 1 hour time period) at 25°C environment temperature

Screw jacks SJ Series

Screw jacks SJ Series with 1-start acme screw TECHNICAL SPECIFICATIONS

SJ 250	SJ 300	SJ 350	SJ 400	SJ 600	SJ 800	SJ 1000	SCREW JACK SIZE	
250	300	350	400	600	800	1000	Load capacity [kN], (push - pull)	
Tr 80x12	Tr 90x12	Tr 100x12	Tr 100x12	Tr 120x14	Tr 140x14	Tr 160x16	1-start acme screw	
90	110	110	140	140	200	200	Worm gear centre distance [mm]	
—	—	—	—	—	—	—	RH	
1 : 7 (4 : 28)	3 : 29	3 : 29	3 : 28	3 : 28	3 : 35	3 : 35	RV	
—	—	—	—	—	—	—	RN	
1 : 28	1 : 30	1 : 30	1 : 29	1 : 29	1 : 36	1 : 36	RL	
—	—	—	—	—	—	—	RH1	
1.71	1.24	1.24	1.29	1.5	1.2	1.37	RV1	
—	—	—	—	—	—	—	RN1	
0.43	0.4	0.4	0.41	0.48	0.39	0.44	RL1	
—	—	—	—	—	—	—	RH1	
0.17	0.15	0.13	0.13	0.13	0.12	0.11	RV1	
—	—	—	—	—	—	—	RN1	
0.11	0.09	0.09	0.08	0.08	0.08	0.07	RL1	
—	—	—	—	—	—	—	RH1	
0.35	0.31	0.29	0.30	0.31	0.28	0.28	RV1	
—	—	—	—	—	—	—	RN1	
0.24	0.22	0.21	0.21	0.21	0.21	0.19	RL1	
—	—	—	—	—	—	—	RH1	
360	350	450	540	960	1175	1675	RV1	
—	—	—	—	—	—	—	RN1	
138	175	225	270	485	605	860	RL1	
—	—	—	—	—	—	—	RH1	
4	8	8	15	17	20	25	RV1	
—	—	—	—	—	—	—	RN1	
3.2	6.5	6.5	12	14	17	22	RL1	
1 650	2 150	2 700	3 100	5 500	8 500	12 000	Reactive torque on acme screw (nut) required at max. load [Nm]	
casting in cast iron EN-GJL-250 (UNI EN 1561)			welded structure in steel S355J2 (UNI EN 10025)				Gear box material	
75	120	120	260	260	800	800	Mass of screw jack without acme screw [kg]	
3.4	4.4	5.5	5.5	7.9	10.9	14.2	Mass for every 100 mm of acme screw [kg]	

(¹) - efficiency figures at different input speed on page 55

(²) - THERMAL limit, referred to work with max. duty cycle 30 % over 10 min time period (20 % over 1 hour time period)
at 25°C environment temperature

Screw jacks SJ Series - 1-start acme screw

Following tables show the screw jack LINEAR SPEED v [mm/s] and relative TORQUE T_1 [Nm] and POWER P_1 [kW] on input shaft, with reference to the INPUT SPEED n_1 [rpm], the RATIO (RV, RN, RL) and the LOAD [kN] applied on the screw jack.

Intermediate values for linear speed v , torque T_1 and power P_1 at different input speed can be calculated by linear interpolation of the figures stated in the table.

The figures in the tables refer to work with max. duty cycle of 30 % over 10 min time period or 20 % over 1 hour time period at 25°C environment temperature.

ATTENTION! The figures in the **red shaded area** indicate operational restrictions due to thermal limits. When the selection is made within such area, the duty cycle must be reduced or the greater size screw jack must be selected, in order to allow effective heat dissipation. For a better evaluation, please contact SERVOMECH Engineering Dpt.

SJ 5					LOAD																							
					5 kN								3 kN								1 kN							
n_1 [rpm]	LINEAR SPEED v [mm/s]				RATIO								RATIO								RATIO							
	RH1	RV1	RN1	RL1	RH1		RV1		RN1		RL1		RH1		RV1		RN1		RL1		RH1		RV1		RN1		RL1	
					T_1 Nm	P_1 kW	T_1 Nm	P_1 kW	T_1 Nm	P_1 kW	T_1 Nm	P_1 kW	T_1 Nm	P_1 kW	T_1 Nm	P_1 kW	T_1 Nm	P_1 kW	T_1 Nm	P_1 kW	T_1 Nm	P_1 kW	T_1 Nm	P_1 kW	T_1 Nm	P_1 kW	T_1 Nm	P_1 kW
1500	25	16	8	4	1.9	0.29	1.3	0.20	0.7	0.12	0.5	0.07	1.1	0.17	0.8	0.12	0.4	0.07	0.3	0.04	0.4	0.06	0.3	0.04	0.1	0.02	0.1	0.01
1000	16.7	10.7	5.3	2.7	2.0	0.21	1.4	0.14	0.8	0.09	0.5	0.05	1.2	0.12	0.8	0.09	0.5	0.05	0.3	0.03	0.4	0.04	0.3	0.03	0.2	0.02	0.1	0.01
750	12.5	8	4	2	2.1	0.16	1.4	0.11	0.8	0.07	0.5	0.04	1.3	0.10	0.8	0.07	0.5	0.04	0.3	0.03	0.4	0.03	0.3	0.02	0.2	0.01	0.1	0.01
500	8.3	5.3	2.7	1.3	2.3	0.12	1.5	0.08	0.9	0.05	0.6	0.03	1.4	0.07	0.9	0.05	0.5	0.03	0.3	0.02	0.5	0.02	0.3	0.02	0.2	0.01	0.1	0.01
300	5	3.2	1.6	0.8	2.4	0.08	1.6	0.05	1.0	0.03	0.6	0.02	1.5	0.05	1.0	0.03	0.6	0.02	0.4	0.01	0.5	0.02	0.3	0.01	0.2	0.01	0.1	0.01
100	1.7	1.1	0.5	0.3	2.8	0.03	2.0	0.02	1.1	0.01	0.7	0.01	1.7	0.02	1.2	0.01	0.7	0.01	0.4	0.01	0.6	0.01	0.4	0.01	0.2	0.01	0.1	0.01
50	0.8	0.5	0.3	0.1	3.1	0.02	2.0	0.01	1.2	0.01	0.7	0.01	1.8	0.01	1.2	0.01	0.7	0.01	0.4	0.01	0.6	0.01	0.4	0.01	0.2	0.01	0.1	0.01

SJ 10					LOAD																									
					10 kN						8 kN						6 kN						2 kN							
n_1 [rpm]	LINEAR SPEED v [mm/s]				RATIO						RATIO						RATIO						RATIO							
	RV1	RN1	RL1	RV1	RN1	RL1	RV1	RN1	RL1	RV1	RN1	RL1	RV1	RN1	RL1	RV1	RN1	RL1	RV1	RN1	RL1	RV1	RN1	RL1	RV1	RN1	RL1	RV1	RN1	RL1
1500	31.3	7.8	5.2	5.6	0.87	1.8	0.28	1.3	0.21	4.4	0.70	1.4	0.22	1.1	0.17	3.3	0.52	1.1	0.17	0.8	0.13	1.1	0.17	0.4	0.06	0.3	0.04			
1000	20.8	5.2	3.5	5.8	0.63	1.8	0.19	1.4	0.15	4.7	0.49	1.5	0.15	1.1	0.12	3.5	0.37	1.1	0.12	0.8	0.09	1.2	0.12	0.4	0.04	0.3	0.03			
750	15.6	3.9	2.6	6.0	0.47	1.9	0.15	1.5	0.11	4.8	0.38	1.5	0.12	1.2	0.09	3.6	0.28	1.2	0.09	0.9	0.07	1.2	0.10	0.4	0.03	0.3	0.02			
500	10.4	2.6	1.7	6.4	0.34	2.0	0.11	1.6	0.08	5.1	0.27	1.6	0.08	1.3	0.07	3.9	0.20	1.2	0.06	1.0	0.05	1.3	0.07	0.4	0.02	0.3	0.02			
300	6.3	1.6	1.1	6.6	0.21	2.1	0.07	1.7	0.05	5.3	0.17	1.7	0.05	1.3	0.04	4.0	0.13	1.3	0.04	1.0	0.03	1.3	0.04	0.4	0.01	0.3	0.01			
100	2.1	0.5	0.4	7.1	0.08	2.3	0.02	2.0	0.02	5.7	0.06	1.8	0.02	1.6	0.02	4.3	0.05	1.4	0.02	1.2	0.01	1.4	0.02	0.5	0.01	0.4	0.01			
50	1.1	0.3	0.2	7.4	0.04	2.5	0.01	2.1	0.01	5.9	0.03	2.0	0.01	1.7	0.01	4.4	0.02	1.5	0.01	1.3	0.01	1.5	0.01	0.5	0.01	0.2	0.01			

SJ 25					LOAD																									
					25 kN						20 kN						15 kN						10 kN							
n_1 [rpm]	LINEAR SPEED v [mm/s]				RATIO						RATIO						RATIO						RATIO							
	RV1	RN1	RL1	RV1	RN1	RL1	RV1	RN1	RL1	RV1	RN1	RL1	RV1	RN1	RL1	RV1	RN1	RL1	RV1	RN1	RL1	RV1	RN1	RL1	RV1	RN1	RL1	RV1	RN1	RL1
1500	25	8.3	6.3	11.7	1.83	4.8	0.76	3.9	0.61	9.3	1.47	3.9	0.60	3.1	0.49	7.0	1.10	2.9	0.45	2.3	0.37	4.6	0.74	1.9	0.30	1.6	0.25			
1000	16.7	5.6	4.2	12.2	1.28	5.0	0.53	4.1	0.43	9.8	1.03	4.0	0.42	3.3	0.34	7.3	0.77	3.0	0.32	2.5	0.26	4.8	0.52	2.0	0.21	1.6	0.18			
750	12.5	4.2	3.1	12.7	1.00	5.2	0.41	4.2	0.33	10.2	0.80	4.2	0.33	3.4	0.27	7.6	0.60	3.1	0.24	2.5	0.20	5.0	0.40	2.1	0.16	1.7	0.14			
500	8.3	2.8	2.1	13.5	0.71	5.5	0.29	4.5	0.24	10.8	0.56	4.4	0.23	3.6	0.19	8.1	0.42	3.3	0.17	2.7	0.14	5.4	0.28	2.2	0.12	1.8	0.10			
300	5	1.7	1.3	14.1	0.44	5.8	0.18	4.8	0.15	11.3	0.35	4.6	0.15	3.9	0.12	8.5	0.27	3.5	0.11	2.9	0.09	5.6	0.09	2.4	0.08	2.0	0.06			
100	1.7	0.6	0.4	15.1	0.16	6.5	0.07	5.5	0.06	12.1	0.13	5.2	0.05	4.4	0.05	9.0	0.09	3.9	0.04	3.3	0.03	6.0	0.06	2.6	0.03	2.2	0.03			
50	0.8	0.3	0.2	15.8	0.08	6.9	0.04	6.0	0.03	12.6	0.07	5.5	0.03	4.8	0.02	9.5	0.05	4.1	0.02	3.6	0.02	6.5	0.04	2.8	0.02	2.4	0.01			

SJ 50					LOAD																									
					50 kN						35 kN						25 kN						10 kN							
n_1 [rpm]	LINEAR SPEED v [mm/s]				RATIO						RATIO						RATIO						RATIO							
	RV1	RN1	RL1	RV1	RN1	RL1	RV1	RN1	RL1	RV1	RN1	RL1	RV1	RN1	RL1	RV1	RN1	RL1	RV1	RN1	RL1	RV1	RN1	RL1	RV1	RN1	RL1	RV1	RN1	RL1
1500	25	12.5	6.3	25.0	3.92	14.4	2.26	8.5	1.34	17.5	2.74	10.0	1.58	6.0	0.94	12.5	1.96	7.2	1.13	4.3	0.67	5.0	0.78	2.9	0.45	1.7	0.27			
1000	16.7	8.3	4.2	26.5	2.78	13.3	1.60	9.1	0.96	18.6	1.94	10.7	1.12	6.4	0.67	13.3	1.39	7.6	0.80	4.6	0.48	5.3	0.56	3.1	0.32	1.8	0.19			
750	12.5	6.3	3.1	27.4	2.15	16.0	1.25	9.5	0.74	19.2	1.51	11.1	0.87	6.6	0.52	13.7	1.08	7.9	0.62	4.7	0.37	5.5	0.43	3.2	0.25	1.9	0.15			
500	8.3	4.2	2.1	28.8	1.51	16.4	0.86	10.0	0.52	20.2	1.06	11.5	0.60	7.0	0.37	14.4	0.75	8.2	0.43	5.0	0.26	5.8	0.30	3.3	0.17	2.0	0.11			
300	5	2.5	1.3	30.5	0.96	17.4	0.55	10.8	0.34	21.3	0.67	12.2	0.38	7.6	0.24	15.2	0.48	8.7	0.27	5.4	0.17	6.1	0.19	3.5	0.11	2.1	0.07			
100	1.7	0.8	0.4	33.0	0.35	19.3	0.20	12.5	0.13	23.1	0.24	13.5	0.14	8.8	0.09	16.5	0.17	9.7	0.10	6.3	0.07	6.6	0.07	3.9	0.04	2.5	0.03			
50	0.8	0.4	0.2	35.0	0.18	21.0	0.11	13.6	0.07	24.3	0.13	14.5	0.08	9.5	0.05	17.4	0.09	10.3	0.05	6.8	0.04	7.0	0.04	4.1	0.02	2.7	0.01			

Screw jacks SJ Series - 1-start acme screw

Following tables show the screw jack LINEAR SPEED v [mm/s] and relative TORQUE T_1 [Nm] and POWER P_1 [kW] on input shaft, with reference to the INPUT SPEED n_1 [rpm], the RATIO (RV, RN, RL) and the LOAD [kN] applied on the screw jack.

Intermediate values for linear speed v , torque T_1 and power P_1 at different input speed can be calculated by linear interpolation of the figures stated in the table.

The figures in the tables refer to work with max. duty cycle of 30 % over 10 min time period or 20 % over 1 hour time period at 25°C environment temperature.

ATTENTION! The figures in the **red shaded area** indicate operational restrictions due to thermal limits. When the selection is made within such area, the duty cycle must be reduced or the greater size screw jack must be selected, in order to allow effective heat dissipation. For a better evaluation, please contact SERVOMECH Engineering Dpt.

SJ 100				LOAD																							
				100 kN				80 kN				60 kN				40 kN											
				RATIO		RATIO		RATIO		RATIO		RATIO		RATIO		RATIO		RATIO									
n_1 [rpm]	LINEAR SPEED v [mm/s]			RV1	RN1	RL1	RV1	RN1	RL1	RV1	RN1	RL1	RV1	RN1	RL1	RV1	RN1	RL1									
	RV1	RN1	RL1	T_1 Nm	P_1 kW	T_1 Nm	P_1 kW	T_1 Nm	P_1 kW	T_1 Nm	P_1 kW	T_1 Nm	P_1 kW	T_1 Nm	P_1 kW	T_1 Nm	P_1 kW	T_1 Nm	P_1 kW	T_1 Nm	P_1 kW						
1 500	32.0	16.0	8.0							16.3	2.56	37.6	5.91	21.8	3.43	12.2	1.92	25.1	3.94	14.6	2.29	8.2	1.28				
1 000	21.4	10.7	5.3			39.1	4.10	25.0	2.62	53.4	5.59	30.2	3.16	17.0	1.78	40.0	4.19	22.6	2.37	12.7	1.33	26.7	2.80	15.1	1.58	8.5	0.89
750	16.1	8.0	4.0	68.4	5.37	42.2	3.31	26.3	2.06	54.7	4.22	32.6	2.56	17.7	1.39	41.0	3.17	24.4	1.92	13.3	1.04	27.3	2.11	16.3	1.28	8.9	0.70
500	10.7	5.3	2.7	73.2	3.83	44.5	2.34	27.5	1.44	58.2	3.05	34.0	1.78	18.5	0.97	43.7	2.29	25.5	1.33	13.9	0.73	29.1	1.52	17.0	0.89	9.3	0.48
300	6.4	3.2	1.6	82.4	2.59	47.6	1.50	30.6	0.96	63.7	2.00	35.1	1.10	22.3	0.70	47.7	1.50	26.3	0.83	16.8	0.53	31.8	1.00	17.5	0.55	11.2	0.35
100	2.1	1.1	0.5	91.5	0.96	55.5	0.58	35.6	0.37	66.2	0.69	37.6	0.39	24.0	0.25	49.7	0.52	28.2	0.30	18.0	0.19	33.1	0.35	18.8	0.20	12.0	0.13
50	1.1	0.5	0.3	98.9	0.52	59.5	0.31	39.9	0.21	69.0	0.36	40.7	0.21	25.5	0.13	51.7	0.27	30.6	0.16	19.1	0.10	34.5	0.18	20.4	0.11	12.7	0.07

SJ 150				LOAD																							
				150 kN				120 kN				80 kN				50 kN											
				RATIO		RATIO		RATIO		RATIO		RATIO		RATIO		RATIO		RATIO									
n_1 [rpm]	LINEAR SPEED v [mm/s]			RV1	RN1	RL1	RV1	RN1	RL1	RV1	RN1	RL1	RV1	RN1	RL1	RV1	RN1	RL1									
	RV1	RN1	RL1	T_1 Nm	P_1 kW	T_1 Nm	P_1 kW	T_1 Nm	P_1 kW	T_1 Nm	P_1 kW	T_1 Nm	P_1 kW	T_1 Nm	P_1 kW	T_1 Nm	P_1 kW	T_1 Nm	P_1 kW	T_1 Nm	P_1 kW						
1 500	37.5	12.5	9.4							33.7	5.29	27.6	4.34			22.4	3.52	18.4	2.89	32.0	5.02	14.0	2.20	11.5	1.81		
1 000	25	8.3	6.3			46.9	4.91	38.2	4.00			37.5	3.93	30.5	3.20	55.3	5.79	25.0	2.62	20.4	2.13	34.6	3.62	15.6	1.64	12.7	1.33
750	18.8	6.3	4.7			49.3	3.87	39.0	3.06	86.0	6.75	39.4	3.09	31.2	2.45	57.3	4.50	26.3	2.06	20.8	1.63	35.8	2.81	16.4	1.29	13.0	1.02
500	12.5	4.2	3.1	116	6.06	51.1	2.68	41.4	2.17	92.6	4.85	40.9	2.14	33.1	1.73	61.7	3.23	27.3	1.43	22.1	1.16	38.6	2.02	17.0	0.89	13.8	0.72
300	7.5	2.5	1.9	128	4.01	55.6	2.75	46.8	1.47	102	3.21	44.5	1.40	37.5	1.18	68.0	2.14	29.6	0.93	25.0	0.78	42.5	1.34	18.5	0.58	15.6	0.49
100	2.5	0.8	0.6	140	1.46	64.4	0.67	54.5	0.57	112	1.17	51.6	0.54	43.6	0.46	74.4	0.78	34.4	0.36	29.1	0.30	46.5	0.49	21.5	0.22	18.2	0.19
50	1.3	0.4	0.3	150	0.78	72.6	0.38	61.4	0.32	120	0.63	58.1	0.30	49.1	0.26	79.9	0.42	38.7	0.20	32.7	0.17	49.9	0.26	24.2	0.13	20.5	0.11

SJ 200				LOAD															
				200 kN				150 kN				100 kN				50 kN			
				RATIO		RATIO		RATIO		RATIO		RATIO		RATIO		RATIO			
n_1 [rpm]	LINEAR SPEED v [mm/s]			RV1	RL1	RV1	RL1	RV1	RL1	RV1	RL1	RV1	RL1						
	RV1	RL1	T_1 Nm	P_1 kW	T_1 Nm	P_1 kW	T_1 Nm	P_1 kW	T_1 Nm	P_1 kW	T_1 Nm	P_1 kW	T_1 Nm	P_1 kW					
1 500	42.9	10.7						39.6	6.23			26.4	4.15	37.8	5.94	13.2	2.08		
1 000	28.6	7.1			60.1	6.29			45.1	4.72	81.2	8.50	30.0	3.15	40.6	4.25	15.0	1.57	
750	21.4	5.4			64.5	5.07	129	10.1	48.4	3.80	86.0	6.76	32.26	2.53	43.0	3.38	16.1	1.27	
500	14.3	3.6	185	9.68	67.6	3.54	139	7.26	50.7	2.5	92.4	4.84	33.8	1.77	46.2	2.42	16.9	0.88	
300	8.6	2.1	201	6.32	75.8	2.38	151	4.74	56.8	1.79	101	3.16	37.9	1.19	50.3	1.58	18.9	0.60	
100	2.9	0.7	228	2.39	86.8	0.91	171	1.79	65.1	0.68	114	1.20	43.4	0.45	57.1	0.60	21.7	0.23	
50	1.4	0.4	252	1.32	98.9	0.52	189	0.99	74.2	0.39	126	0.66	49.4	0.26	62.9	0.33	24.7	0.13	

SJ 250				LOAD																					
				250 kN				200 kN				150 kN				100 kN									
				RATIO		RATIO		RATIO		RATIO		RATIO		RATIO		RATIO									
n_1 [rpm]	LINEAR SPEED v [mm/s]			RV1	RL1	RV1	RL1	RV1	RL1	RV1	RL1	RV1	RL1												
	RV1	RL1	T_1 Nm	P_1 kW	T_1 Nm	P_1 kW	T_1 Nm	P_1 kW	T_1 Nm	P_1 kW	T_1 Nm	P_1 kW	T_1 Nm	P_1 kW											
1 500	42.9	10.7										42.9	6.74			28.6	4.49								
1 000	28.6	7.1										63.8	6.68			47.9	5.01	87.1	9.12	31.9	3.34				
750	21.4	5.4										69.7	5.47			52.3	4.10	91.0	7.15	34.8	2.74				
500	14.3	3.6										92.9	4.87	195	10.2	74.4	3.89	146	7.65	55.8	2.92	97.3	5.10	37.2	1.95
300	8.6	2.1	264	8.29	103	3.22	211	6.63	82.1	2.58	158	4.97	61.6	1.93	106	3.31	41.1	1.29							
100	2.9	0.7	313	3.28	119	1.24	251	2.62	95.1	1.00	188	1.97	71.3	0.75	125	1.31	47.5	0.50							
50	1.4	0.4	339	1.77	137	0.72	271	1.42	109	0.57	203	1.06	82.0	0.43	135	0.71	54.7	0.29							



Screw jacks SJ Series - 1-start acme screw

Following tables show the screw jack LINEAR SPEED v [mm/s] and relative TORQUE T_1 [Nm] and POWER P_1 [kW] on input shaft, with reference to the INPUT SPEED n_1 [rpm], the RATIO (RV, RN, RL) and the LOAD [kN] applied on the screw jack.

Intermediate values for linear speed v , torque T_1 and power P_1 at different input speed can be calculated by linear interpolation of the figures stated in the table.

The figures in the tables refer to work with max. duty cycle of 30 % over 10 min time period or 20 % over 1 hour time period at 25°C environment temperature.

ATTENTION! The figures in the **red shaded area** indicate operational restrictions due to thermal limits. When the selection is made within such area, the duty cycle must be reduced or the greater size screw jack must be selected, in order to allow effective heat dissipation. For a better evaluation, please contact SERVOMECH Engineering Dpt.

SJ 300			LOAD															
			300 kN				250 kN				200 kN				100 kN			
			RATIO		RATIO		RATIO		RATIO		RATIO		RATIO		RATIO			
n_1 [rpm]	LINEAR SPEED v [mm/s]		RV1	RL1	T_1 Nm	P_1 kW	T_1 Nm	P_1 kW	T_1 Nm	P_1 kW	T_1 Nm	P_1 kW	T_1 Nm	P_1 kW	T_1 Nm	P_1 kW		
	RV1	RL1																
1 500	31.0	10			86.4	13.6			72.0	11.3	130	20.5	57.6	9.05	65.1	10.2	28.8	4.52
1 000	20.7	6.7			97.0	10.2	176	18.4	80.8	8.46	141	14.8	64.7	6.77	70.4	7.37	32.3	3.39
750	15.5	5	223	17.5	105	8.24	186	14.6	87.4	6.87	149	11.7	69.9	5.49	74.4	5.84	35.0	2.75
500	10.3	3.3	242	12.7	113	5.93	202	10.6	94.3	4.94	161	8.45	75.5	3.95	80.7	4.23	37.7	1.98
300	6.2	2	270	8.48	121	3.80	225	7.06	101	3.16	180	5.65	80.6	2.53	90.0	2.83	40.3	1.27
100	2.1	0.7	307	3.21	148	1.55	256	2.68	123	1.29	205	2.14	98.6	1.03	102	1.07	49.3	0.52
50	1.0	0.3	341	1.78	167	0.87	284	1.49	139	0.73	227	1.19	111	0.58	114	0.59	55.5	0.29

SJ 350			LOAD															
			350 kN				300 kN				200 kN				100 kN			
			RATIO		RATIO		RATIO		RATIO		RATIO		RATIO		RATIO			
n_1 [rpm]	LINEAR SPEED v [mm/s]		RV1	RL1	T_1 Nm	P_1 kW	T_1 Nm	P_1 kW	T_1 Nm	P_1 kW	T_1 Nm	P_1 kW	T_1 Nm	P_1 kW	T_1 Nm	P_1 kW		
	RV1	RL1																
1 500	31.0	10							92.2	14.5			61.4	9.65	66.5	10.5	30.7	4.83
1 000	20.7	6.7			119	12.5			102	10.7	149	15.6	68.0	7.12	74.6	7.81	34.0	3.56
750	15.5	5			129	10.1	235	18.5	111	8.68	157	12.3	73.7	5.79	78.3	6.15	36.9	2.89
500	10.3	3.3	299	15.6	142	7.4	256	13.4	122	6.37	171	8.94	81.1	4.25	85.3	4.47	40.5	2.12
300	6.2	2	337	10.6	151	4.75	289	9.07	130	4.07	192	6.04	86.4	2.71	96.2	3.02	43.2	1.36
100	2.1	0.7	388	4.06	186	1.95	332	3.48	159	1.67	222	2.32	106	1.11	111	1.16	53.2	0.56
50	1.0	0.3	425	2.22	208	1.09	364	1.91	178	0.93	243	1.27	119	0.62	121	0.64	59.4	0.31

SJ 400			LOAD															
			400 kN				300 kN				200 kN				100 kN			
			RATIO		RATIO		RATIO		RATIO		RATIO		RATIO		RATIO			
n_1 [rpm]	LINEAR SPEED v [mm/s]		RV1	RL1	T_1 Nm	P_1 kW	T_1 Nm	P_1 kW	T_1 Nm	P_1 kW	T_1 Nm	P_1 kW	T_1 Nm	P_1 kW	T_1 Nm	P_1 kW		
	RV1	RL1																
1 500	32.1	10.3			125	19.7	206	32.4	94.1	14.8	137	21.6	62.7	9.86	68.7	10.8	31.4	4.93
1 000	21.4	6.9	303	31.7	141	14.7	227	22.8	106	11.1	152	15.9	70.4	7.37	75.8	7.93	35.2	3.69
750	16.1	5.2	323	25.4	149	11.7	242	19.0	112	8.79	161	12.7	74.6	5.86	80.7	6.34	37.3	2.93
500	10.7	3.4	344	18.3	166	8.71	258	13.5	125	6.53	172	9.01	83.2	4.35	86.1	4.51	41.6	2.18
300	6.4	2.1	393	12.4	178	5.60	295	9.27	134	4.20	197	6.18	89.1	2.80	98.4	3.09	44.5	1.40
100	2.1	0.7	458	4.79	219	2.29	343	3.60	164	1.72	229	2.40	109	1.14	114	1.20	54.7	0.57
50	1.1	0.3	510	2.67	250	1.31	384	2.00	187	0.98	255	1.34	125	0.65	128	0.67	62.4	0.33

SJ 600			LOAD															
			600 kN				500 kN				400 kN				200 kN			
			RATIO		RATIO		RATIO		RATIO		RATIO		RATIO		RATIO			
n_1 [rpm]	LINEAR SPEED v [mm/s]		RV1	RL1	T_1 Nm	P_1 kW	T_1 Nm	P_1 kW	T_1 Nm	P_1 kW	T_1 Nm	P_1 kW	T_1 Nm	P_1 kW	T_1 Nm	P_1 kW		
	RV1	RL1																
1 500	37.5	12.1			220	34.5			183	28.8			146	23.0	155	24.4	73.2	11.5
1 000	25	8.0			241	25.1			200	21.0	349	36.5	160	16.8	174	18.3	80.0	8.38
750	18.8	6.0			263	20.7	471	37.0	219	17.2	377	29.6	175	13.8	188	14.8	87.7	6.88
500	12.5	4.0	608	31.8	292	15.3	507	26.5	243	12.8	405	21.2	195	10.2	203	10.6	97.4	5.50
300	7.5	2.4	671	21.1	316	9.94	559	17.6	264	8.28	447	14.1	211	6.62	224	7.03	105	3.31
100	2.5	0.8	813	8.51	397	4.15	677	7.09	330	3.46	542	5.67	264	2.77	271	2.84	132	1.8
50	1.3	0.4	893	4.68	437	2.29	744	3.90	364	1.91	595	3.12	291	1.52	298	1.56	146	0.76

Screw jacks SJ Series - 1-start acme screw

Following tables show the screw jack LINEAR SPEED v [mm/s] and relative TORQUE T_1 [Nm] and POWER P_1 [kW] on input shaft, with reference to the INPUT SPEED n_1 [rpm], the RATIO (RV, RN, RL) and the LOAD [kN] applied on the screw jack.

Intermediate values for linear speed v , torque T_1 and power P_1 at different input speed can be calculated by linear interpolation of the figures stated in the table.

The figures in the tables refer to work with max. duty cycle of 30 % over 10 min time period or 20 % over 1 hour time period at 25°C environment temperature.

ATTENTION! The figures in the **red shaded area** indicate operational restrictions due to thermal limits. When the selection is made within such area, the duty cycle must be reduced or the greater size screw jack must be selected, in order to allow effective heat dissipation. For a better evaluation, please contact SERVOMECH Engineering Dpt.

SJ 800			LOAD															
			800 kN				600 kN				400 kN				200 kN			
			RATIO		RATIO		RATIO		RATIO		RATIO		RATIO		RATIO			
n_1 [rpm]	LINEAR SPEED v [mm/s]		RV1	RL1	T_1 Nm	P_1 kW	T_1 Nm	P_1 kW	T_1 Nm	P_1 kW	T_1 Nm	P_1 kW	T_1 Nm	P_1 kW	T_1 Nm	P_1 kW	T_1 Nm	P_1 kW
	1 500	30	9.7			263	41.4			197	31.0	280	44.0	132	20.8	140	22.0	65.8
1 000	20	6.5			284	29.8	472	49.4	213	22.3	314	33.0	142	14.9	157	16.5	71.1	7.44
750	15	4.9			309	24.3	501	39.4	232	18.2	334	26.2	155	12.2	167	13.1	77.3	6.07
500	10	3.2	722	37.8	349	18.3	541	28.4	262	13.7	361	18.9	175	9.15	180	9.45	87.4	4.57
300	6	1.9	827	26.0	379	11.9	620	19.5	284	8.94	414	13.0	190	5.95	207	6.50	94.8	2.98
100	2	0.6	978	10.2	480	5.02	733	7.68	360	3.77	489	5.12	240	2.51	244	2.56	120	1.26
50	1	0.3	1 076	5.63	527	2.76	807	4.23	395	2.07	538	2.82	263	1.38	269	1.41	132	0.69

SJ 1000			LOAD															
			1000 kN				800 kN				600 kN				400 kN			
			RATIO		RATIO		RATIO		RATIO		RATIO		RATIO		RATIO			
n_1 [rpm]	LINEAR SPEED v [mm/s]		RV1	RL1	T_1 Nm	P_1 kW	T_1 Nm	P_1 kW	T_1 Nm	P_1 kW	T_1 Nm	P_1 kW	T_1 Nm	P_1 kW	T_1 Nm	P_1 kW	T_1 Nm	P_1 kW
	1 500	34.3	11.1							294	46.2			220	34.7	312	49.0	147
1 000	22.9	7.4			402	42.1			321	33.7	520	54.5	241	25.2	347	36.3	161	16.8
750	17.1	5.6			437	34.3	737	58.0	350	27.5	553	43.5	262	20.6	369	29.0	175	13.7
500	11.4	3.7	1 008	52.8	486	25.4	806	42.2	388	20.3	605	31.7	291	15.2	403	21.1	194	10.1
300	6.9	2.2	1 148	36.1	541	17.0	918	28.9	433	13.6	689	21.6	325	10.2	459	14.4	217	6.80
100	2.3	0.7	1 397	14.6	679	7.11	1 117	11.7	543	5.69	838	8.77	408	4.27	559	5.85	272	2.85
50	1.1	0.4	1 544	8.08	760	3.98	1 235	6.47	608	3.18	926	4.85	456	2.39	618	3.23	304	1.59

Total efficiency of screw jack with 1-start acme screw

η	SJ 5				SJ 10			SJ 25			SJ 50			SJ 100			SJ 150		
	RH1	RV1	RN1	RL1	RV1	RN1	RL1	RV1	RN1	RL1	RV1	RN1	RL1	RV1	RN1	RL1	RV1	RN1	RL1
1 500	0.35	0.34	0.29	0.25	0.36	0.28	0.25	0.34	0.27	0.25	0.32	0.28	0.23	0.33	0.29	0.24	0.37	0.28	0.26
1 000	0.33	0.32	0.28	0.24	0.34	0.27	0.24	0.32	0.26	0.24	0.30	0.26	0.22	0.31	0.27	0.23	0.35	0.25	0.23
750	0.32	0.31	0.27	0.23	0.33	0.26	0.23	0.31	0.25	0.23	0.29	0.25	0.21	0.30	0.26	0.22	0.33	0.24	0.23
500	0.30	0.29	0.26	0.21	0.31	0.25	0.21	0.29	0.24	0.22	0.28	0.24	0.20	0.29	0.25	0.21	0.31	0.23	0.22
300	0.29	0.28	0.25	0.20	0.30	0.24	0.20	0.28	0.23	0.20	0.26	0.23	0.18	0.27	0.24	0.19	0.28	0.21	0.19
100	0.27	0.26	0.23	0.17	0.28	0.22	0.17	0.26	0.20	0.18	0.24	0.21	0.16	0.25	0.22	0.17	0.26	0.19	0.16
50	0.26	0.25	0.21	0.16	0.27	0.20	0.16	0.25	0.19	0.17	0.23	0.19	0.15	0.24	0.20	0.16	0.24	0.16	0.15
AT START	0.22	0.22	0.19	0.15	0.23	0.18	0.14	0.20	0.16	0.13	0.18	0.15	0.11	0.20	0.17	0.13	0.21	0.14	0.13

η	SJ 200		SJ 250		SJ 300		SJ 350		SJ 400		SJ 600		SJ 800		SJ 1000	
	RV1	RL1	RV1	RL1	RV1	RL1	RV1	RL1	RV1	RL1	RV1	RL1	RV1	RL1	RV1	RL1
1 500	0.36	0.26	0.35	0.24	0.30	0.22	0.30	0.21	0.30	0.21	0.31	0.21	0.27	0.19	0.28	0.19
1 000	0.34	0.23	0.31	0.21	0.28	0.20	0.26	0.19	0.27	0.19	0.27	0.19	0.24	0.17	0.25	0.18
750	0.32	0.21	0.30	0.20	0.27	0.18	0.25	0.17	0.25	0.18	0.25	0.18	0.23	0.16	0.24	0.16
500	0.30	0.20	0.28	0.18	0.24	0.17	0.23	0.16	0.24	0.16	0.24	0.16	0.21	0.14	0.22	0.15
300	0.27	0.18	0.26	0.17	0.22	0.16	0.21	0.15	0.21	0.15	0.21	0.15	0.18	0.13	0.19	0.13
100	0.24	0.16	0.22	0.14	0.19	0.13	0.18	0.12	0.18	0.12	0.18	0.12	0.16	0.10	0.16	0.10
50	0.22	0.14	0.20	0.12	0.17	0.11	0.16	0.11	0.16	0.11	0.16	0.11	0.14	0.09	0.14	0.09
AT START	0.19	0.12	0.17	0.11	0.14	0.09	0.13	0.09	0.13	0.08	0.13	0.08	0.11	0.07	0.11	0.07

Screw jacks SJ Series

Screw jacks SJ Series with 2-starts acme screw TECHNICAL SPECIFICATIONS

SCREW JACK SIZE		SJ 5	SJ 10	SJ 25	SJ 50	SJ 100	SJ 150	SJ 200	
Load capacity [kN], (push - pull)		5	10	25	50	100	150	200	
2-starts acme screw		Tr 18x8 (P4)	Tr 22x10 (P5)	Tr 30x12 (P6)	Tr 40x14 (P7)	Tr 55x18 (P9)	Tr 60x24 (P12)	Tr 70x24 (P12)	
Worm gear centre distance [mm]		25	30	50	63	63	80	90	
Available ratio	RH	1 : 4 (5 : 20)	—	—	—	—	—	—	
	RV	1 : 6.25(4 : 25)	1 : 4 (4 : 16)	1 : 6 (4 : 24)	1 : 7 (4 : 28)	1 : 7 (4 : 28)	1 : 8 (4 : 32)	1 : 7 (4 : 28)	
	RN	1 : 12.5(2 : 25)	1 : 16 (2 : 32)	1 : 18 (2 : 36)	1 : 14 (2 : 28)	1 : 14 (2 : 28)	1 : 24	—	
	RL	1 : 25	1 : 24	1 : 24	1 : 28	1 : 28	1 : 32	1 : 28	
Stroke [mm] for 1 input shaft revolution	Ratio	RH1	2	—	—	—	—	—	
		RV1	1.28	2.5	2	2	2.57	3	3.43
		RN1	0.64	0.625	0.67	1	1.29	1	—
		RL1	0.32	0.42	0.5	0.5	0.64	0.75	0.86
Starting efficiency	Ratio	RH1	0.32	—	—	—	—	—	
		RV1	0.32	0.33	0.31	0.29	0.28	0.30	0.28
		RN1	0.28	0.26	0.23	0.24	0.23	0.21	—
		RL1	0.21	0.20	0.20	0.18	0.17	0.19	0.18
Running efficiency at 1500 rpm ⁽¹⁾	Ratio	RH1	0.48	—	—	—	—	—	
		RV1	0.45	0.50	0.47	0.46	0.46	0.49	0.48
		RN1	0.41	0.38	0.38	0.40	0.40	0.39	—
		RL1	0.33	0.34	0.34	0.33	0.33	0.36	0.36
Starting torque on input shaft at max. load [Nm]	Ratio	RH1	5	—	—	—	—	—	
		RV1	3.2	12.2	26.0	56	149	238	391
		RN1	1.9	3.9	11.4	33.5	90	114	—
		RL1	1.2	3.3	10.0	22.4	60	94	153
Max. permissible operating power [kW] ⁽²⁾	Ratio	RH1	0.55	—	—	—	—	—	
		RV1	0.55	0.80	1.6	3.4	3.5	4	5.5
		RN1	0.28	0.40	1	2.4	2.4	3.6	—
		RL1	0.25	0.34	0.8	1.6	1.6	3.5	4.4
Reactive torque on acme screw (nut) required at max. load [Nm]		12	30	100	250	650	1 150	1 700	
Gear box material		casting in aluminium alloy EN 1706 - AC-AISI10Mg T6			casting in cast iron EN-GJL-250 (UNI EN 1561)				
Mass of screw jack without acme screw [kg]		1.5	2.3	10.4	25	35	55	75	
Mass for every 100 mm of acme screw [kg]		0.16	0.23	0.45	0.8	1.6	1.8	2.5	

⁽¹⁾ - efficiency figures at different input speed on page 61

⁽²⁾ - THERMAL limit, referred to work with max. duty cycle 30 % over 10 min time period (20 % over 1 hour time period) at 25°C environment temperature

Screw jacks SJ Series

Screw jacks SJ Series with 2-starts acme screw TECHNICAL SPECIFICATIONS

SJ 250	SJ 300	SJ 350	SJ 400	SJ 600	SJ 800	SJ 1000	SCREW JACK SIZE	
250	300	350	400	600	800	1000	Load capacity [kN], (push - pull)	
Tr 80x24 (P12)	Tr 90x24 (P12)	Tr 100x24 (P12)	Tr 100x24 (P12)	Tr 120x28 (P14)	Tr 140x28 (P14)	Tr 160x32 (P16)	2-starts acme screw	
90	110	110	140	140	200	200	Worm gear centre distance [mm]	
—	—	—	—	—	—	—	RH	
1 : 7 (4 : 28)	3 : 29	3 : 29	3 : 28	3 : 28	3 : 35	3 : 35	RV Available ratio	
—	—	—	—	—	—	—	RN	
1 : 28	1 : 30	1 : 30	1 : 29	1 : 29	1 : 36	1 : 36	RL	
—	—	—	—	—	—	—	RH1	
3.43	2.48	2.48	2.57	3	2.4	2.74	RV1 Ratio	
—	—	—	—	—	—	—	RN1	
0.86	0.8	0.8	0.83	0.97	0.78	0.89	RL1	
—	—	—	—	—	—	—	RH1	
0.28	0.23	0.21	0.21	0.20	0.18	0.18	RV1 Ratio	
—	—	—	—	—	—	—	RN1	
0.18	0.15	0.14	0.13	0.13	0.11	0.11	RL1	
—	—	—	—	—	—	—	RH1	
0.48	0.43	0.42	0.42	0.43	0.40	0.41	RV1 Ratio	
—	—	—	—	—	—	—	RN1	
0.36	0.33	0.31	0.31	0.31	0.29	0.29	RL1	
—	—	—	—	—	—	—	RH1	
527	521	650	790	1 407	1 685	2 405	RV1 Ratio	
—	—	—	—	—	—	—	RN1	
206	257	320	399	711	866	1 237	RL1	
—	—	—	—	—	—	—	RH1	
5.5	11	11	21	23	30	36	RV1 Ratio	
—	—	—	—	—	—	—	RN1	
4.4	9	9	17	20	26	33	RL1	
2 280	2 950	3 680	4 200	7 500	11 100	15 900	Reactive torque on acme screw (nut) required at max. load [Nm]	
casting in cast iron EN-GJL-250 (UNI EN 1561)			welded structure in steel S355J2 (UNI EN 10025)				Gear box material	
75	120	120	260	260	800	800	Mass of screw jack without acme screw [kg]	
3.4	4.4	5.5	5.5	7.9	10.9	14.2	Mass for every 100 mm of acme screw [kg]	

(¹) - efficiency figures at different input speed on page 61

(²) - THERMAL limit, referred to work with max. duty cycle 30 % over 10 min time period (20 % over 1 hour time period)
at 25°C environment temperature

Screw jacks SJ Series - 2-starts acme screw

Following tables show the screw jack LINEAR SPEED v [mm/s] and relative TORQUE T_1 [Nm] and POWER P_1 [kW] on input shaft, with reference to the INPUT SPEED n_1 [rpm], the RATIO (RV, RN, RL) and the LOAD [kN] applied on the screw jack.

Intermediate values for linear speed v , torque T_1 and power P_1 at different input speed can be calculated by linear interpolation of the figures stated in the table.

The figures in the tables refer to work with max. duty cycle of 30 % over 10 min time period or 20 % over 1 hour time period at 25°C environment temperature.

ATTENTION! The figures in the **red shaded area** indicate operational restrictions due to thermal limits. When the selection is made within such area, the duty cycle must be reduced or the greater size screw jack must be selected, in order to allow effective heat dissipation. For a better evaluation, please contact SERVOMECH Engineering Dpt.

SJ 300			LOAD															
			300 kN				250 kN				200 kN				100 kN			
			RATIO		RATIO		RATIO		RATIO		RATIO		RATIO		RATIO			
n_1 [rpm]	LINEAR SPEED v [mm/s]		RV2	RL2	T_1 Nm	P_1 kW	T_1 Nm	P_1 kW	T_1 Nm	P_1 kW	T_1 Nm	P_1 kW	T_1 Nm	P_1 kW	T_1 Nm	P_1 kW		
	RV2	RL2																
1 500	62.1	20			117	18.4			97.9	15.4			78.3	12.3	92.5	14.5	39.1	6.15
1 000	41.4	13.3			129	13.5	246	25.7	108	11.3	197	20.6	86.2	9.03	98.3	10.3	43.1	4.51
750	31.0	10	308	24.2	139	10.9	257	20.2	115	9.07	206	16.2	92.4	7.25	103	8.08	46.2	3.63
500	20.7	6.7	329	17.2	148	7.77	274	14.4	124	6.48	219	11.5	99.0	5.18	110	5.75	49.5	2.59
300	12.4	4	359	11.3	158	4.95	299	9.39	131	4.13	239	6.51	105	3.30	120	3.76	52.5	1.65
100	4.1	1.3	402	4.21	190	1.99	335	3.51	158	1.65	268	2.80	126	1.32	138	1.40	63.2	0.66
50	2.1	0.7	439	2.30	212	1.11	366	1.92	177	0.92	293	1.53	141	0.74	146	0.77	70.6	0.37

SJ 350			LOAD															
			350 kN				300 kN				200 kN				100 kN			
			RATIO		RATIO		RATIO		RATIO		RATIO		RATIO		RATIO			
n_1 [rpm]	LINEAR SPEED v [mm/s]		RV2	RL2	T_1 Nm	P_1 kW	T_1 Nm	P_1 kW	T_1 Nm	P_1 kW	T_1 Nm	P_1 kW	T_1 Nm	P_1 kW	T_1 Nm	P_1 kW		
	RV2	RL2																
1 500	62.1	20							123	19.3			82.1	12.9	93.9	14.7	41.0	6.45
1 000	41.4	13.3			157	16.4			134	14.1	205	21.5	89.5	9.37	103	10.7	44.8	4.69
750	31.0	10			168	13.2	320	25.1	144	11.34	213	16.7	96.2	7.56	107	8.37	48.1	3.78
500	20.7	6.7	399	20.9	183	9.57	342	17.9	157	8.20	228	12.0	104	5.47	114	5.98	52.2	2.73
300	12.4	4	441	13.9	194	6.11	378	11.9	167	5.24	252	7.92	111	3.49	126	3.96	55.6	1.75
100	4.1	1.3	499	5.23	235	2.46	428	4.48	201	2.11	285	2.92	134	1.41	143	1.49	67.1	0.70
50	2.1	0.7	540	2.82	260	1.36	462	2.42	223	1.17	308	1.61	148	0.78	154	0.81	74.4	0.39

SJ 400			LOAD															
			400 kN				300 kN				200 kN				100 kN			
			RATIO		RATIO		RATIO		RATIO		RATIO		RATIO		RATIO			
n_1 [rpm]	LINEAR SPEED v [mm/s]		RV2	RL2	T_1 Nm	P_1 kW	T_1 Nm	P_1 kW	T_1 Nm	P_1 kW	T_1 Nm	P_1 kW	T_1 Nm	P_1 kW	T_1 Nm	P_1 kW		
	RV2	RL2																
1 500	64.3	20.7			168	26.4	291	45.7	126	19.8	194	30.4	83.9	13.2	96.2	15.2	42.0	6.59
1 000	42.9	13.8	418	43.8	185	19.3	313	32.8	139	14.5	209	21.9	92.3	9.67	104	10.9	46.2	4.83
750	32.1	10.3	439	34.5	195	15.3	329	25.9	146	11.5	219	17.2	97.4	7.65	110	8.62	48.7	3.83
500	21.4	6.9	464	24.3	214	11.2	348	18.2	161	8.41	232	12.1	108	5.61	116	6.07	53.6	2.80
300	12.9	4.1	516	16.2	229	7.20	387	12.2	172	5.40	258	8.11	115	3.60	129	4.05	57.3	1.80
100	4.3	1.4	589	6.17	276	2.89	442	4.63	207	2.17	295	3.08	138	1.45	142	1.54	69.0	0.72
50	2.1	0.7	646	3.38	313	1.64	485	2.54	234	1.23	323	1.69	156	0.82	162	0.85	78.2	0.41

SJ 600			LOAD															
			600 kN				500 kN				400 kN				200 kN			
			RATIO		RATIO		RATIO		RATIO		RATIO		RATIO		RATIO			
n_1 [rpm]	LINEAR SPEED v [mm/s]		RV2	RL2	T_1 Nm	P_1 kW	T_1 Nm	P_1 kW	T_1 Nm	P_1 kW	T_1 Nm	P_1 kW	T_1 Nm	P_1 kW	T_1 Nm	P_1 kW		
	RV2	RL2																
1 500	75	24.1			294	46.1			245	38.4			196	30.8	221	34.7	97.9	15.4
1 000	50	16.1			317	33.2			264	27.7	482	50.5	211	22.1	241	25.3	106	11.1
750	37.5	12.1			342	26.8	640	50.3	285	22.4	512	40.2	228	17.9	256	20.1	114	8.94
500	25	8.0	816	42.7	377	19.7	680	35.6	314	16.4	544	21.5	251	13.1	272	14.3	126	6.57
300	15	4.8	886	27.9	405	12.7	739	23.2	337	10.6	591	18.6	270	8.48	295	9.28	135	4.24
100	5	1.6	1 041	10.9	498	5.21	867	9.08	415	4.35	694	7.27	332	3.48	347	3.63	166	1.74
50	2.5	0.8	1 128	5.91	547	2.86	940	4.92	456	2.39	752	3.94	365	1.91	376	1.97	182	0.95

Screw jacks SJ Series - overall dimensions

Model A - TRAVELLING SCREW

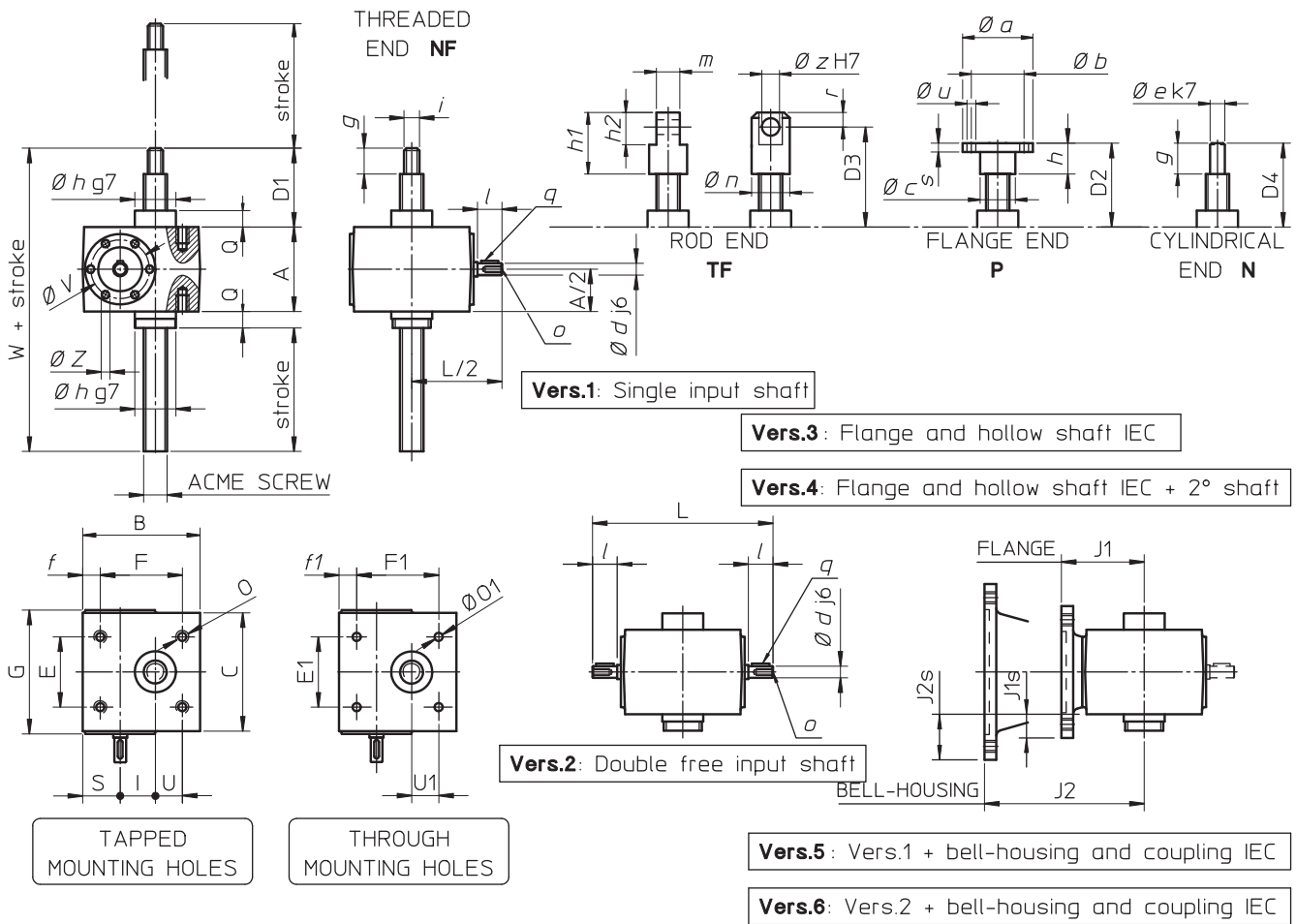

3

Model B - TRAVELLING NUT

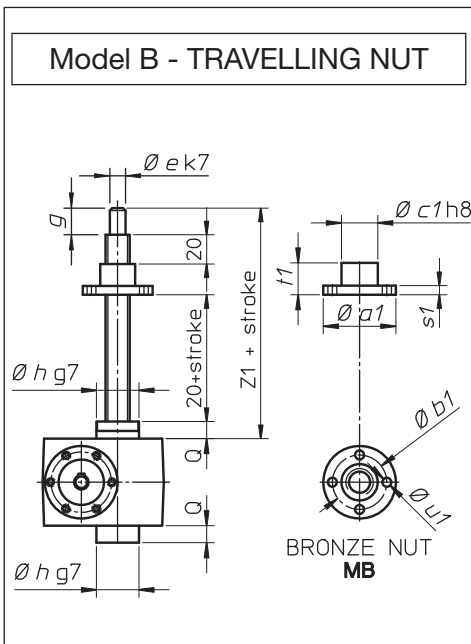

PROTECTIVE TUBE **T**

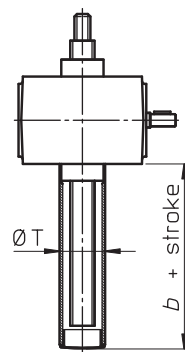

ANTI-TURN DEVICE **AR**

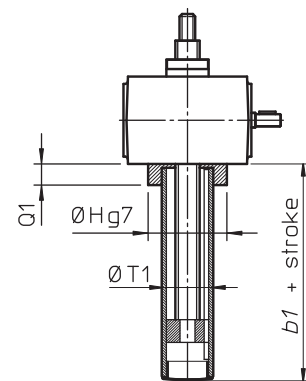

SIZE	SJ 5	SJ 10	SJ 25	SJ 50	SJ 100	SJ 150	SJ 200	SJ 250
ØT	35	40	50	65	102	102	130	130
exec. T	37	43	48	57	65	65	75	75
b								
exec. T + SN	87	93	128	137	155	155	155	155
exec. T + FCM	86	93	98	-	-	-	-	-
exec. T + FCP	87	93	98	107	115	115	115	115
ØH	55	70	85	115	-	-	-	-
Q1	21	18	25	32	-	-	-	-
ØT1	45	55	70	90	100	100	130	130
b1								
exec. AR	86	88	105	102	135	145	135	145
exec. AR + FCP	96	98	115	122	135	145	135	145

Screw jacks SJ Series - overall dimensions

SIZE	SJ 5	SJ 10	SJ 25	SJ 50	SJ 100	SJ 150	SJ 200	SJ 250
ACME SCREW	Tr 18x4	Tr 22x 5	Tr 30x6	Tr 40x7	Tr 55x9	Tr 60x12	Tr 70x12	Tr 80x12
A	62	76	82	118	160	164	176	176
B	100	110	160	200	220	282	280	280
C	86	96	130	160	170	201	230	230
D1 (min.)	51	62	81	90	108	108	118	118
D2 (min.)	52	63	83	92	110	110	120	120
D3 (min.)	77	93	118	137	160	190	210	210
D4 (min.)	51	62	81	90	108	108	118	118
E	52	63	81	115	134	150	180	180
E1	56	80	102	130	120	150	180	180
F	60	78	106	150	175	220	230	230
F1	80	85	131	165	180	220	230	230
G	90	100	136	165	165	205	—	—
I	25	30	50	63	63	80	90	90
L	135	165	221.5	269	269	330	350	350
O	M8, depth 14	M8, depth 15	M10, depth 15	M12, depth 16	M20, depth. 30	M30, depth 45	M30, depth 45	M30, depth 45
∅ O1	9	9	11	13	17	28	32	32
Q	12	18	23	32	40	40	40	40
S	37	40	50	59	74	94	75	75
U	21	29	42	63	60	75	90	90
U1	28	30	48	60	63	75	90	90
∅ V	46	46	64	63	63	74	—	—
W	125	156	186	240	308	312	334	334
Z	M6, depth 13 (4 holes at 90°)	M5, depth 10 (6 holes at 60°)	M5, depth 10 (6 holes at 60°)	M6, depth 14 (6 holes at 60°)	M6, depth 14 (6 holes at 60°)	M6, depth 14 (6 holes at 60°)	—	—
Z1	111	127	151	185	228	228	268	248
∅ a	68	75	100	120	150	150	180	180
∅ a1	68	75	100	120	130	150	180	190
∅ b	45	55	75	85	110	110	130	130
∅ b1	50	56	75	90	105	120	140	150
∅ c	25	30	40	50	70	70	85	85
∅ c1	30	40	50	60	75	80	100	110
∅ d	9	14	19	24	24	28	30	30
∅ e	12	15	20	30	40	40	50	60
f	23	21	36	35	22	29	25	25
f1	10	15	17	17	20	29	25	25
g	19	24	38	38	48	48	58	58
h	20	25	40	40	50	50	60	60
∅ h	30	38.7	46	60	90	90	120	120
h1	60	75	100	120	140	180	210	210
h2	30	40	50	70	80	100	120	120
i	M12x1.75	M16x1.5	M20x1.5	M30x2	M42x3	M42x3	M56x3	M56x3
l	20	30	40	50	50	60	55	55
m	20	25	30	40	50	60	75	75
∅ n	32	38	48	68	78	90	108	108
o	M4, depth 8	M6, depth 14	M8, depth 16	M8, depth 16	M8, depth 16	M8, depth 16	M10, depth 18	M10, depth 18
q	3x3x15	5x5x20	6x6x30	8x7x40	8x7x40	8x7x40	8x7x45	8x7x45
r	15	20	25	35	40	50	60	60
s	8	10	12	15	20	20	25	25
s1	12	12	15	25	20	30	35	30
t1	40	45	50	75	100	100	130	110
∅ u, n° holes	∅ 7, 4 holes	∅ 9, 4 holes	∅ 11, 4 holes	∅ 17, 4 holes	∅ 21, 4 holes	∅ 21, 4 holes	∅ 26, 6 holes	∅ 26, 6 holes
∅ u1, n° holes	∅ 7, 4 holes	∅ 9, 4 holes	∅ 11, 4 holes	∅ 17, 4 holes	∅ 17, 4 holes	∅ 21, 4 holes	∅ 26, 6 holes	∅ 18, 4 holes
∅ z	14	20	25	35	40	50	60	60
J1	56 B5/B14: 57.5	63 B5/B14: 62	63/71 B5: 102	80 B5: 100	80 B5: 100	80/90 B5: 120	100/112 B5: 170	100/112 B5: 170
J1s	56 B5: 29 56 B14: 9	63 B5: 32 63 B14: 7	63 B5: 29 71 B5: 39	80 B5: 41	80 B5: 20	80/90 B5: 18	100/112 B5: 37	100/112 B5: 37
J2	63 B5: 98	71 B5: 122 71 B14: 131	80 B5: 182 80 B14: 176 90 B5: 182 90 B14: 182	90 B5: 200 90 B14: 200 100 B5: 220 100 B14: 220	90 B5: 200 90 B14: 200 100/112 B5: 220 100/112 B14: 220	100/112 B5: 240 100/112 B14: 240	132 B5: 292	132 B5: 292
J2s	63 B5: 39	71 B5: 42 71 B14: 15	80 B5: 59 80 B14: 19 90 B5: 59 90 B14: 29	90 B5: 41 90 B14: 11 100 B5: 66 100 B14: 21	90 B5: 20 90 B14: — 100/112 B5: 45 100/112 B14: —	100/112 B5: 43 100/112 B14: —	132 B5: 62	132 B5: 62

Screw jacks SJ Series - overall dimensions

Model A - TRAVELLING SCREW

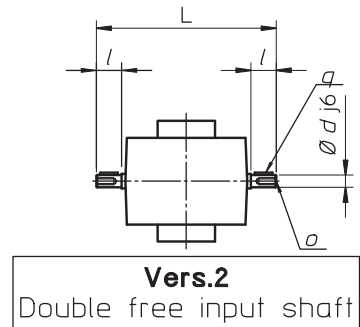
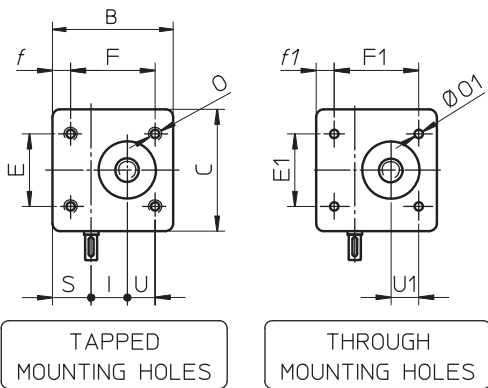
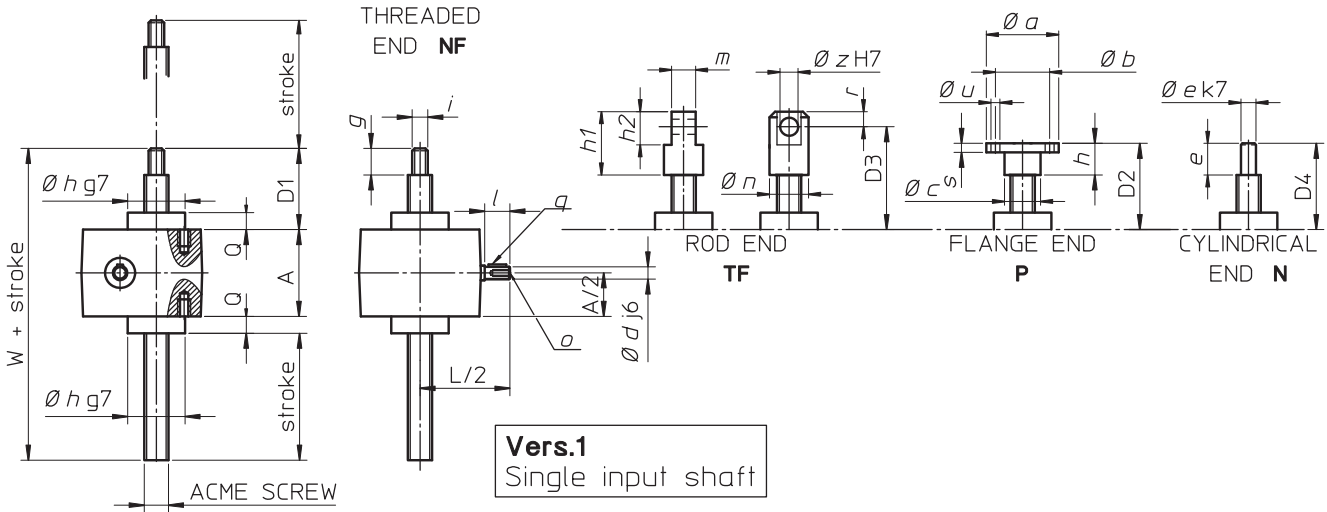

PROTECTIVE TUBE T

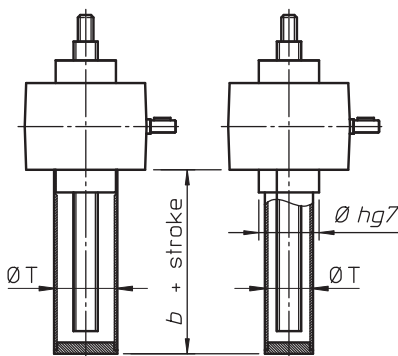

- | | |
|--------|---------|
| SJ 300 | SJ 400 |
| SJ 350 | SJ 600 |
| | SJ 800 |
| | SJ 1000 |

ANTI-TURN DEVICE AR

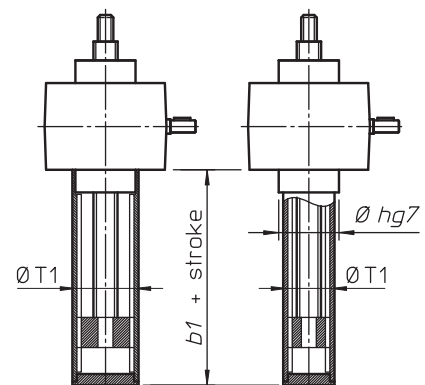

- | | |
|--------|---------|
| SJ 300 | SJ 400 |
| SJ 350 | SJ 600 |
| | SJ 800 |
| | SJ 1000 |

Model B - TRAVELLING NUT

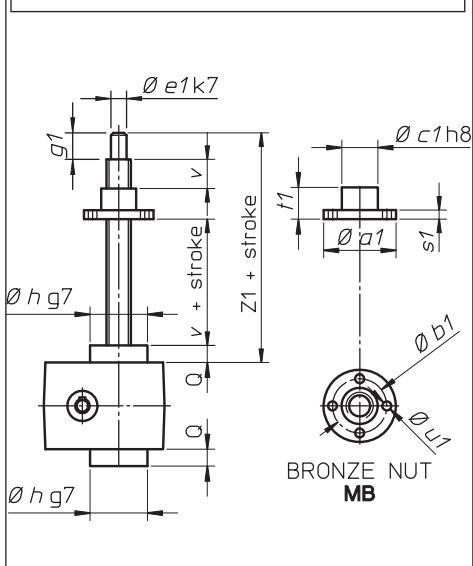

SIZE	SJ 300	SJ 350	SJ 400	SJ 600	SJ 800	SJ 1000
ØT	150	150	200	200	200	200
exec. T	110	110	110	110	130	130
b						
exec. T + SN	210	210	210	210	250	250
exec. T + FCP	160	160	160	160	190	190
ØT1	160	160	200	200	273	273
b1						
exec. AR	190	200	140	150	180	190
exec. AR + FCP	190	200	170	180	210	220

Screw jacks SJ Series - overall dimensions

SIZE	SJ 300	SJ 350	SJ 400	SJ 600	SJ 800	SJ 1000
ACME SCREW	Tr 90x12	Tr 100x12	Tr 100x12	Tr 120x14	Tr 140x14	Tr 160x16
A	230	230	270	270	370	370
B	320	320	418	418	610	610
C	250	250	330	330	500	500
D1 (min.)	158	158	158	178	220	235
D2 (min.)	160	160	160	170	210	210
D3 (min.)	290	290	290	340	410	430
D4 (min.)	210	210	210	240	260	260
E	200	200	230	230	—	—
E1	200	200	230	230	360	360
F	270	270	355	355	—	—
F1	270	270	355	355	510	510
I	110	110	140	140	200	200
L	390	390	490	490	780	780
O	M30, depth 45	M30, depth 45	M30, depth 45	M30, depth 45	—	—
∅ O1	32	32	32	32	60	60
Q	50	50	50	50	60	60
S	85	85	117	117	170	170
U	100	100	135	135	—	—
U1	100	100	135	135	190	190
W	438	438	598	618	650	665
Z1	340	345	345	375	530	530
∅ a	250	278	278	298	378	378
∅ a1	230	230	230	280	320	320
∅ b	180	220	220	240	300	300
∅ b1	190	190	190	235	270	270
∅ c	115	150	150	170	210	210
∅ c1	150	150	150	180	210	210
∅ d	40	40	55	55	70	70
e	120	120	120	150	150	150
∅ e	70	85	85	100	120	140
∅ e1	70	70	70	90	120	130
f	25	25	37	37	—	—
f1	25	25	37	37	50	50
g	68	68	68	88	110	125
g1	80	80	80	85	120	120
h	70	70	70	80	100	100
∅ h	150	150	210	210	300	300
h1	280	280	280	350	440	460
h2	160	160	160	200	280	280
i	M70x6	M70x6	M70x6	M90x6	M110x6	M125x6
l	65	65	75	75	130	130
m	100	100	100	120	155	155
∅ n	138	138	138	168	216	216
o	M10, depth 22	M10, depth 22	M12, depth 28	M12, depth 28	M14, depth 30	M14, depth 30
q	12x8x55	12x8x55	16x10x60	16x10x60	20x12x110	20x12x110
r	80	80	80	100	140	140
s	30	40	40	50	60	60
s1	45	45	45	55	80	80
t1	135	135	135	160	250	250
∅ u, n° holes	∅ 29, 6 holes	∅ 29, 6 holes	∅ 29, 6 holes	∅ 32, 6 holes	∅ 52, 6 holes	∅ 52, 6 holes
∅ u1, n° holes	∅ 20, 4 holes	∅ 20, 4 holes	∅ 20, 4 holes	∅ 25, 4 holes	∅ 25, 6 holes	∅ 25, 6 holes
v	40	40	40	40	50	50
∅ z	80	80	80	100	140	140

Screw jacks SJ Series - options

Screw jack housing fixing holes

On the gear housing of screw jack SJ Series there are fixing holes, which can be tapped holes (on both housing fixing planes) or through holes.

Note that position of threaded holes on the fixing plane differs from the positions of the through holes.

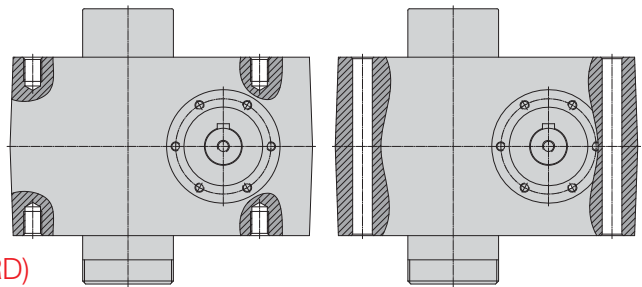

Ordering code: **FF** for threaded holes (STANDARD)
 Ordering code: **FP** for through holes (ON REQUEST)

Stop nut

Available for screw jacks with travelling screw (Mod. A) only.

The mechanical stop prevents the acme screw thread unscrewing clear of the screw jack housing. It is a washer pinned at the acme screw end (opposite the attachment side) that blocks the screw translation when reaching the relative stop.

The acme screw length is defined to allow, under normal use, at the maximum extended position, 20 mm of additional stroke (safety extra-stroke).

If the mechanical stop reaches accidentally the relative stop, it is necessary to check the screw jacks components to verify possible damages.

Ordering code: **SN**

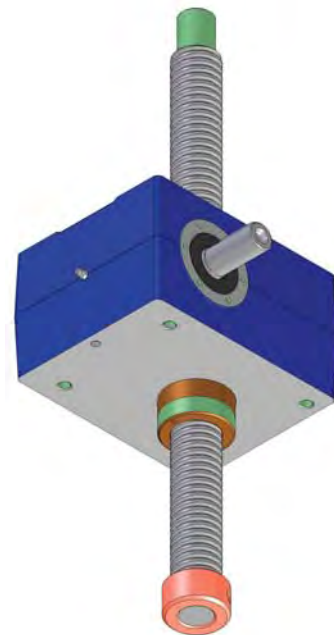

Protective tube

Available for screw jacks with travelling screw (Mod. A) only.

The protective tube is screwed in the raised cover CA and encloses the acme screw below the housing, protecting it from damages and/or environment pollution such as dust, water, etc. Furthermore, it allows the fitting of other options such as limit switches and/or anti-turn device.

Material is aluminium or steel if anti-turn device is fitted.

Ordering code: **T**

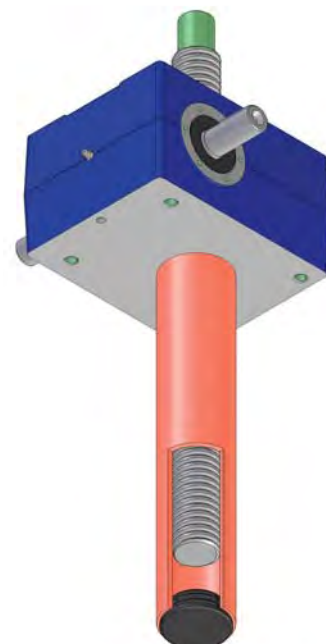

3

Screw jacks SJ Series - options

Anti-turn device

Available for screw jacks with travelling screw (Mod. A) only.

The anti-turn device is necessary when the load to be lifted may turn, i.e. the screw guidance does not prevent rotation, or in case the application does not properly allow the acme screw reaction to permit the translation.

Functioning: a steel key is fitted along the protective tube and a keyed bronze washer is fixed at the end of the acme screw; this prevents the screw rotation and forces the screw translation.

Up to screw jack size 50 (acme screw Tr 40x7) included, the anti-turn device has only one key; from size 100 (acme screw Tr 55x9) on, it has two keys.

The bronze bush also acts as a stop nut against acme screw unthreading.

Ordering code: **AR**

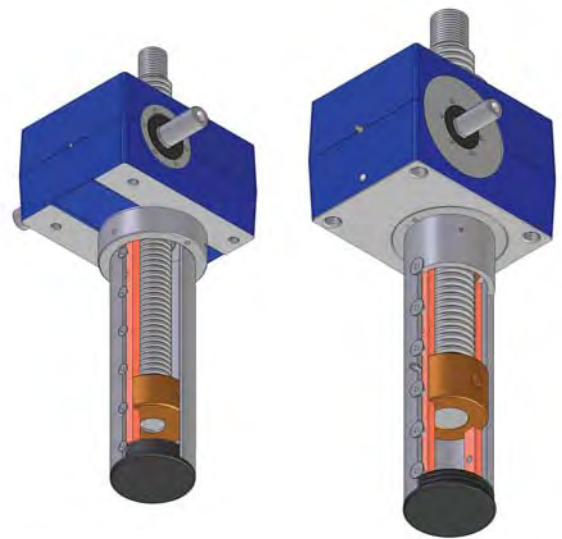

Trunnion mount

Available for both screw jacks models: with travelling screw (Mod. A) and with travelling nut (Mod. B).

The trunnion mount bolts on to either the top or the bottom of the screw jack housing and allows pivoting of the screw jack around the axis defined by trunnion mount's lateral pins.

On screw jack Mod. A: the acme screw attachment must have a cylindrical hole with axis parallel to the trunnion mount lateral pin axis.

On screw jack Mod. B: the part of the machine where the bronze nut MB is fixed must have two lateral cylindrical pins (or holes) with axis parallel to the trunnion mount lateral pin axis.

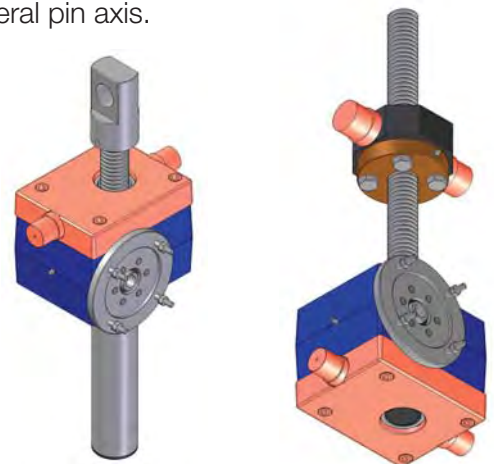
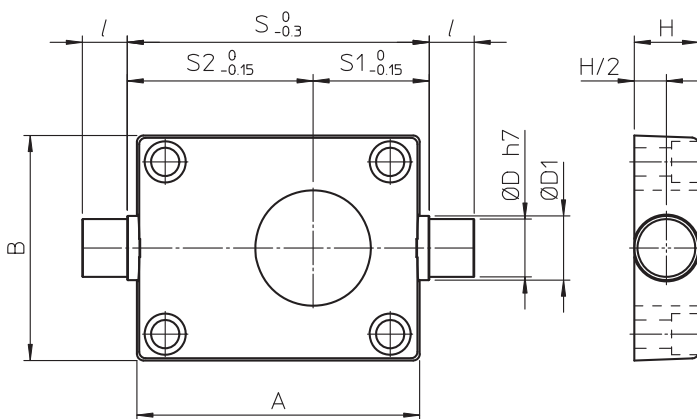

3

	SJ 5	SJ 10	SJ 25	SJ 50	SJ 100	SJ 150	SJ 200	SJ 250	SJ 300	SJ 350
A	100	110	160	200	220	276	280	280	312	312
B	86	100	130	160	170	200	230	230	242	242
ØD	15	20	25	35	45	60	70	70	70	70
ØD ₁	20	25	30	40	50	70	90	90	85	85
H	20	25	30	40	50	80	100	100	100	100
l	15	20	20	30	35	65	75	75	75	75
S	105	115	185	215	235	305	300	300	350	350
S ₁	40.5	42.5	72.5	85.5	90.5	119.5	125	125	140	140
S ₂	64.5	72.5	112.5	129.5	144.5	185.5	175	175	210	210
mass [kg]	1.1	1.8	3.4	7.3	9	30	40	40	40	40

Ordering code: **SC (TF side)** screw jacks Mod. A with SC fitted on side towards screw attachment
 Ordering code: **SC (opp. TF side)** screw jacks Mod. A with SC fitted on side opposite to screw attachment

Ordering code: **SC (screw side)** screw jacks Mod. B with SC fitted on side towards screw
 Ordering code: **SC (opp. screw side)** screw jacks Mod. B with SC fitted on side opposite to screw

Screw jacks SJ Series - options

Bellows

Available for both screw jacks models: with travelling screw (Mod. A) and with travelling nut (Mod. B). In applications with particular environment conditions, bellows protect the screw from contaminants.

Unless otherwise required in the purchase order, bellows supplied are circular, sewn, in NYLON with a PVC outside and inside coating, suitable for industrial applications in general. For special application requirements, bellows in material suitable for use in specific environment (marine environment, food industry, environment with presence of abrasive material, ...) or in different execution (split with zip or velcro, moulded in PVC or rubber bellows, ...) could be supplied on request.

The bellows cause changes to the retracted and extended lengths and screw jack overall dimensions stated in the catalogue. On request, orders will be acknowledged with a screw jack drawing giving exact dimensions.



Screw jacks SJ Mod.A with bellows

Usually, bellows are fitted between the acme screw attachment and worm gearbox, and at the opposite side the protection tube is fitted.

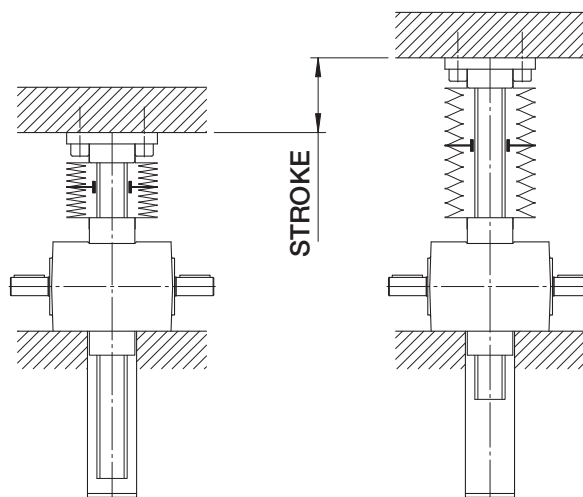

If necessary, a protective bellows can be fitted on the opposite side of the worm gearbox too.

In case the screw jack shall have a screw without attachment (with threaded end NF only), we advise to specify required collar dimensions (\varnothing_c , l) in the purchase order.

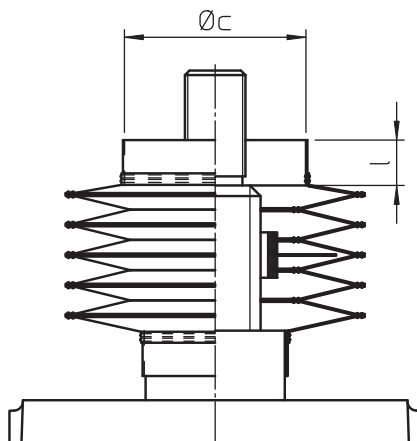

Ordering code: **B**

Screw jacks SJ Series - options

Screw jacks SJ Mod.B with bellows

Bellows are normally fitted between the screw jack housing and the nut and also between the nut and the acme screw end. Some applications may require bellows in only one of these two position.

The dimension of the bellows attachment between screw jack housing and bronze nut is determined by the screw jack's dimensions while the bellows attachment between bronze nut and acme screw end depends on the application structure the bellows shall fit.

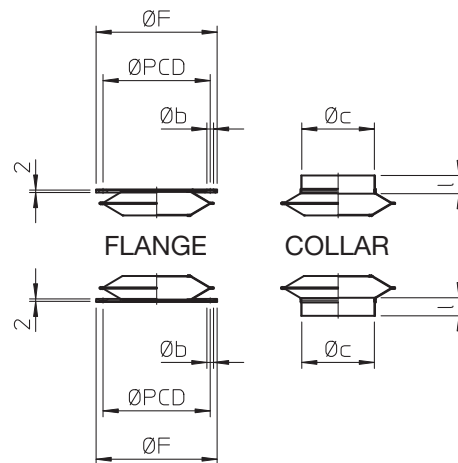
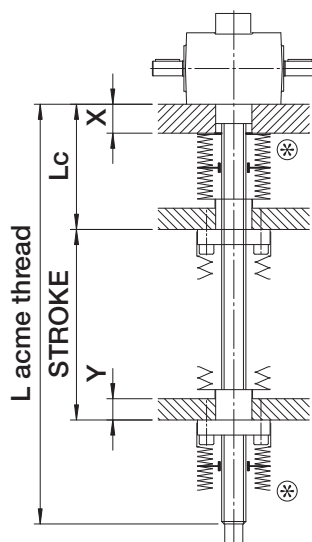
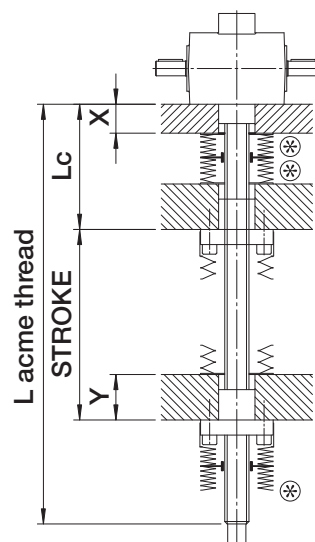
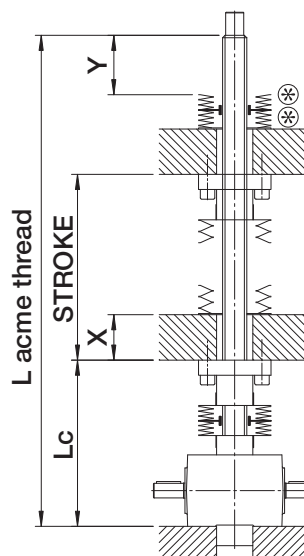
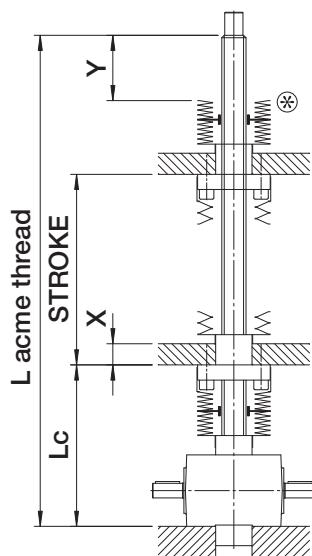
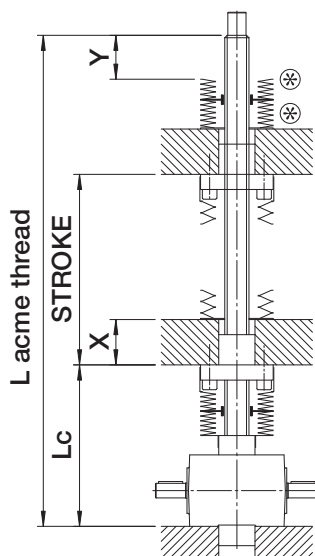
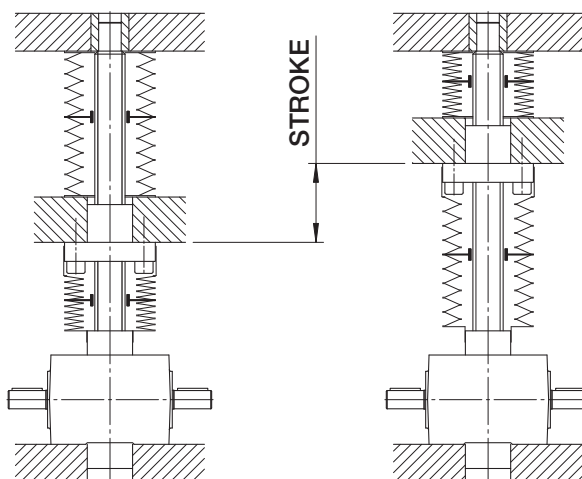
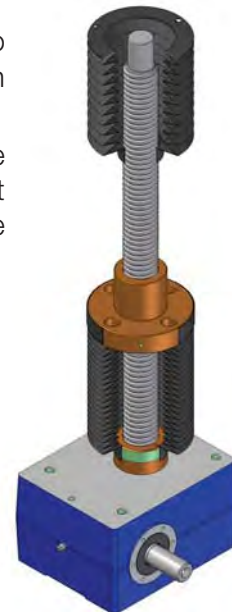

⊗ - bellows attachment dimensions to be defined

Screw jacks SJ Series - options

Safety nut

Available for both screw jacks models: with travelling screw (Mod. A) and with travelling nut (Mod. B).

The safety nut is a back-up feature to prevent the load dropping in an uncontrolled manner in the event of working nut thread breaking due to overload or achieving of critical wear level (wear level that causes the breaking of the remaining thread section with normal working load only).

The safety nut is an extension to the standard nut (wormwheel inside Mod.A screw jacks or external travelling nut of Mod.B screw jacks) and changes the screw jack overall dimensions.

The safety nut works with one particular load direction only. Its position as regards the standard nut is conditioned by the load direction.

Following drawings show a screw jack with safety nut in case of acme screw subjected to push load. In case of pull load, the position of the nut would be on the opposite side of the screw jack housing (Mod. A) or of the external travelling nut (Mod. B).

By new screw jacks, the distance **b** between standard nut and safety nut is equal to the half of the profile pitch (**P**) of the acme thread.

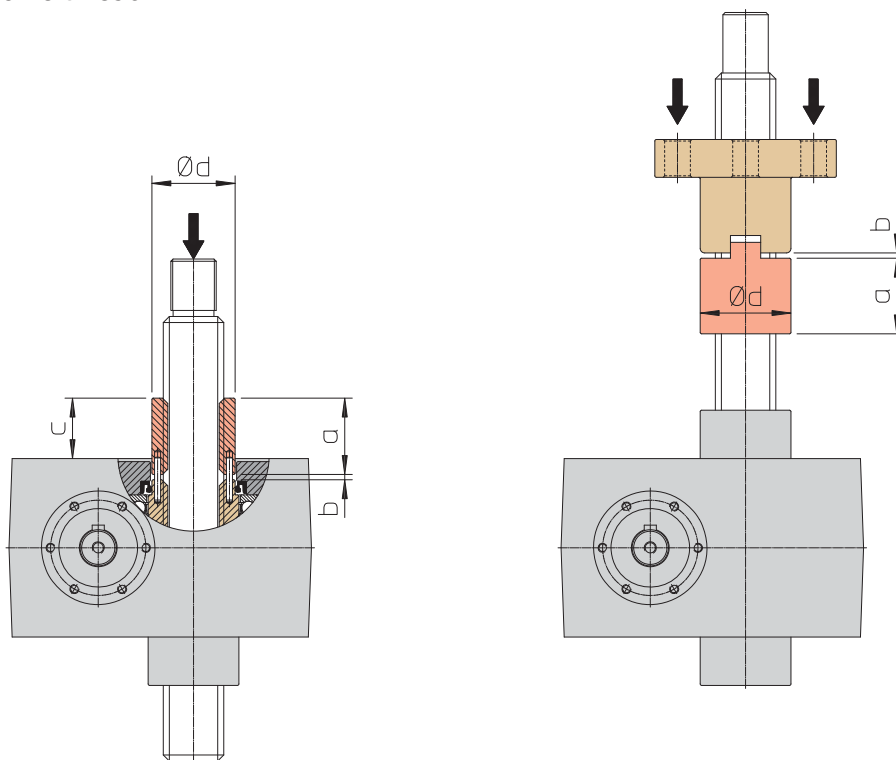

Screw jacks SJ Mod.A with safety nut

	SJ 5	SJ 10	SJ 25	SJ 50	SJ 100	SJ 150	SJ 200	SJ 250	SJ 300	SJ 350	SJ 400	SJ 600	SJ 800	SJ 1000
a	—	33	40	50	70	70	95	95	135	135	135	160	250	250
b	—	2.5	3	3.5	4.5	6	6	6	6	6	6	7	7	8
c	—	14.5	30.5	39.5	53.5	61	88	88	114	114	114	140	215	216
$\varnothing d$	—	30	50	55	70	80	100	100	130	140	150	160	240	240

Ordering code: **MSA push** screw jacks Mod.A with safety nut for push load

Ordering code: **MSA pull** screw jacks Mod.A with safety nut for pull load

Screw jacks SJ Mod.B with safety nut

	SJ 5	SJ 10	SJ 25	SJ 50	SJ 100	SJ 150	SJ 200	SJ 250	SJ 300	SJ 350	SJ 400	SJ 600	SJ 800	SJ 1000
a	28	33	35	50	70	70	95	95	135	135	135	160	250	250
b	2	2.5	3	3.5	4.5	6	6	6	6	6	6	7	7	8
$\varnothing d$	30	40	50	60	75	80	100	100	150	150	150	180	210	210

Ordering code: **SBC push** screw jacks Mod.B with safety nut for push load

Ordering code: **SBC pull** screw jacks Mod.B with safety nut for pull load

Screw jacks SJ Series - options

Acme thread wear level check

Available for both screw jacks models: with travelling screw (Mod. A) and with travelling nut (Mod. B).

Due to working conditions (load, speed, temperature, lubrication), the thread of the working nut wears out. Some applications require the possibility to keep the current wear level under control to prevent reaching the critical wear level and consequent thread breaking by replacing the nut early.

Usually, a value equal to 1/4 of the profile pitch (**P**) of the acme thread is considered as max. wear level admitted.

With thread wear, the distance **b** between working nut and safety nut (see drawings on previous page) reduces to the working nut. By measuring this change, it is possible to get the current wear level of the thread.

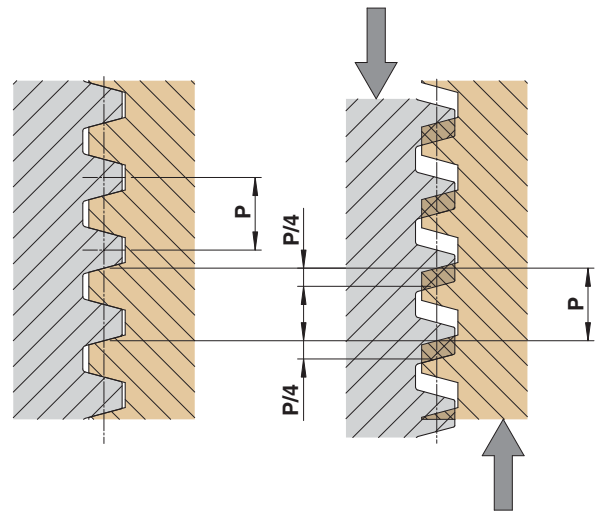

Following drawings show the possible solutions:

- check of dimension **c₁**, **c₂**, **c₃** or **c₄** for screw jacks with travelling screw (Mod. A) or of distance **b** for screw jacks with travelling nut (Mod. B) - see drawings on previous page and below - comparing the current value with the initial one (with new screw jack),
- appliance of an electric switch (see drawings below) which is activated when the pre-established wear level is reached giving an electric signal.

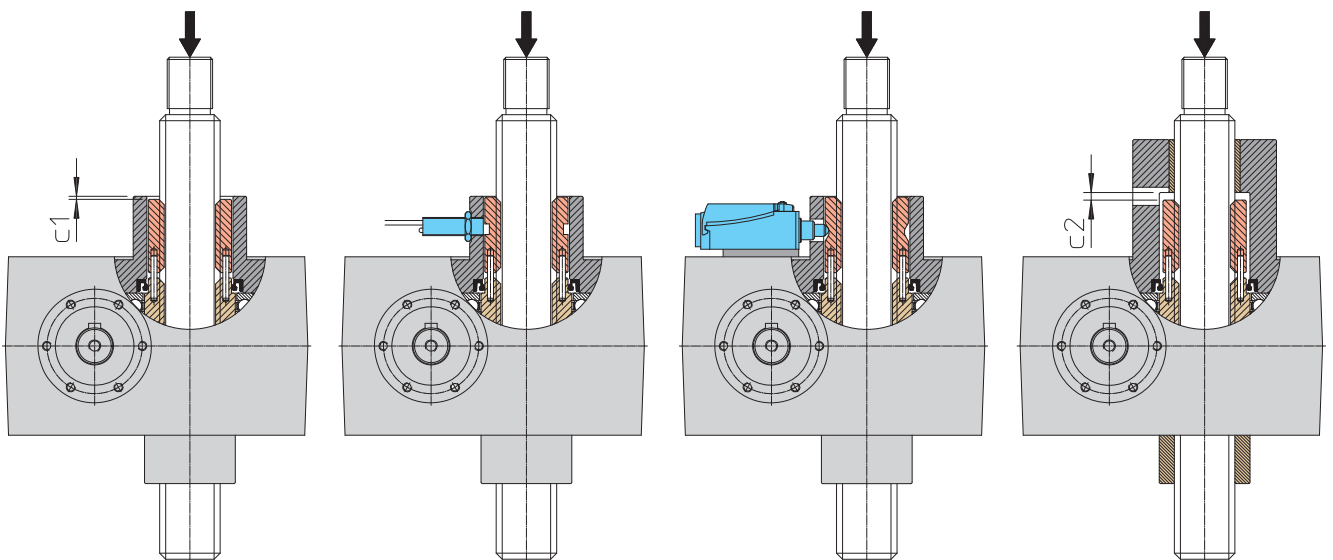

Thread wear control on screw jacks SJ Series Mod.A

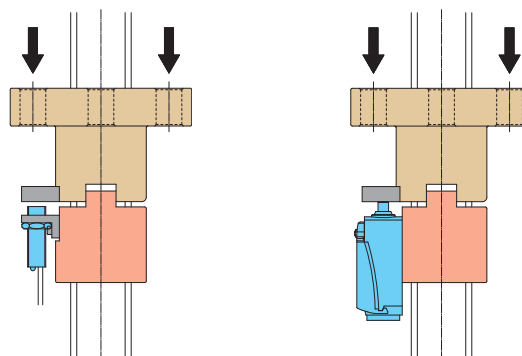

Thread wear control on screw jacks SJ Series Mod.B

Screw jacks SJ Series - options

Wormwheel rotation detector

Available for screw jacks with travelling screw (Mod. A) only.

Some applications require the possibility to verify if the wormwheel rotates while the worm shaft is moving in order to get information about the good condition and functioning of the wormwheel toothing.

Usually, this device is required for applications where a safety nut is already present. A “crown” of empty and full spaces (created by machining the safety nut end, see picture on the right), while rotating, activates a corresponding proximity switch. As output of such proximity switch, activated and deactivated by the alternation of empty and full spaces, a “train” of impulses is generated and it confirms the rotation of the wormwheel. On the contrary, the constant output signal of the proximity means the stop of the wormwheel.

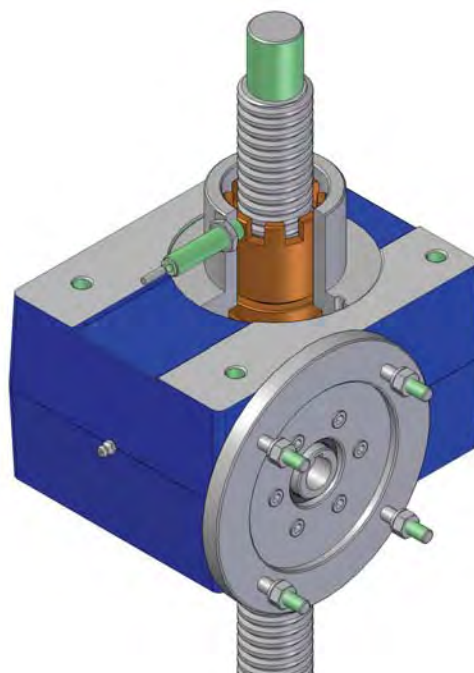

Magnetic stroke end switches

Available for screw jacks with travelling screw (Mod. A) and for size 5, 10 o 25. Not compatible with anti-turn device AR.

Functioning: the magnetic stroke end switches are sensors with reed contact and are fixed with a clamp on the protective tube T, made in aluminium or other non-magnetic metal. They are activated by the magnetic field generated by a magnetic ring fitted on the acme screw end.

In case the screw jack is not stopped after the sensor activation, without magnetic field the sensor restores the original state. In case the limit switches are used to stop the screw jack, we recommend to provide for an electric connection in order to latch the signal and to prevent that the screw jack moves again in the same direction.

Screw jacks with magnetic limit switches are supplied with two sensors for the acme screw extreme positions. On request, extra switches for intermediate distances can be supplied.

The position of the sensors along the tube is adjustable.

Technical details:

Contact:	normally CLOSED (NC)	normally OPEN (NO)
Voltage range:	(3 ... 130) Vdc / (3 ... 130) Vac	
Switching capacity:	20 W / 20 VA	
Max. switching current at 25°C:	300 mA (resistive load)	
Max. inductive load:	3 W (simple coil)	—
Wires	2 × 0.25 mm ²	
Cable length	2 m	

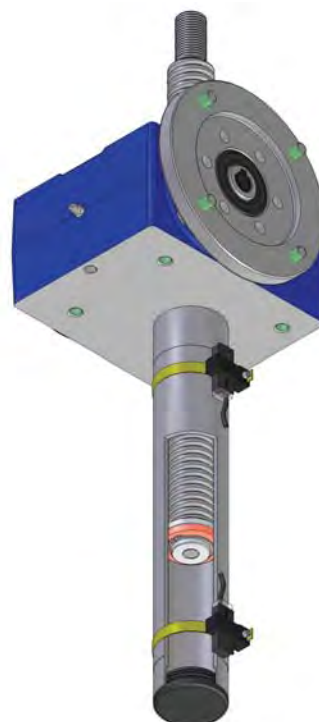

Ordering code: **FCM-NC** for screw jacks with normally closed magnetic switches FCM

Ordering code: **FCM-NO** for screw jacks with normally open magnetic switches FCM

Screw jacks SJ Series - options

Inductive proximity stroke end switches

Available for screw jacks with travelling screw (Mod.A) only.

Functioning: proximity limit switches are PNP inductive sensors with normally CLOSED contact (NC) fitted on the protective tube and activated by the metallic ring fixed on the acme screw end.

In case the screw jack is not stopped after the sensor activation, when the metallic ring moves away the sensor restores the original state (becomes deactivated). In case the limit switches are used to stop the screw jack, we recommend to provide for an electric connection in order to latch the signal and to prevent that the screw jack moves again in the same direction.

Screw jacks with proximity limit switches are supplied with two sensors for the acme screw extreme positions. Extra switches for intermediate distances available on request.

On standard execution, the sensors position along the tube is not adjustable and is not angularly fixed. On request, it can be supplied with angular position at customer's indication.

Execution with axial adjustment of the sensors position available on request.

Technical details:

Type	inductive, PNP
Contact:	normally CLOSED (NC)
Nominal voltage:	(10 ... 30) Vdc
Max. output current:	200 mA
Voltage drop (activated sensor):	< 1.8 V
Wires	3 × 0.2 mm ²
Cable length	2 m

Ordering code: **standard FCP (not adjustable)**
adjustable FCP

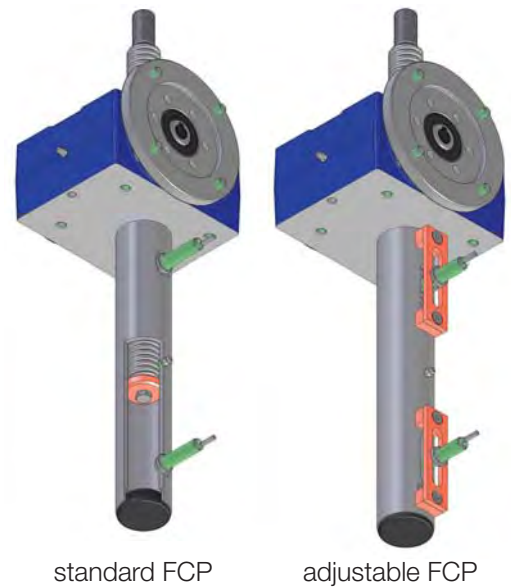

Material: stainless steel

For applications in particular environment conditions or in food industry, the screw jacks SJ Series can be supplied with stainless steel acme screw and/or screw attachment on request. Available steels: AISI 303, AISI 304, AISI 316.

Ordering code: **TR inox** stainless steel acme screw for screw jacks Mod. A or Mod. B

Ordering code: **P inox** stainless steel flange end P, for screw jacks Mod. A

Ordering code: **TF inox** stainless steel rod end TF, for screw jacks Mod. A

IEC motor connection

		SJ 5	SJ 10	SJ 25	SJ 50	SJ 100	SJ 150	SJ 200	SJ 250
56	B5	F							
	B14	F							
63	B5	B	F	F					
	B14		F						
71	B5		B	F	F	F			
	B14		B	F					
80	B5			B	F	F	F		
	B14			B					
90	B5			B	B	B	F		
	B14			B	B	B			
100 - 112	B5				B	B	B	F	F
	B14				B	B	B	B	B
132	B5							B	B

F - plug-in IEC flange and hollow shaft

B - bell-housing + coupling IEC

Flange or bell-housing at drawing for hydraulic motors or servomotors connection available on request.

Screw jacks SJ Series - coding description

Screw jacks SJ Series with travelling screw (Mod.A)

SJ	50	Mod.A	RL1	Vers. 3 (80 B5)	U-RH	FF	C300
1	2	3	4	5	6	7	8
TF	B	MSA	/	SC	T	AR	FCP
9							
...							
10							
...							
11							
AC 3-phase brake motor 0.75 kW 4 poles 230/400 V 50 Hz IP 55 Isol. F							
12							

1 SJ (screw jack SJ Series)

2 Screw jack size

5 ... 1000

page 56 - 57, 62 - 63

3 Mod.A (Model: travelling screw)

4 Ratio and number of acme screw starts

page 56 - 57, 62 - 63

5 Input versions

Vers.1, Vers.2, Vers.3, Vers.4, Vers.5, Vers.6

page 7

6 Screw jack mounting and input shaft position

U-RH, U-LH, D-RH, D-LH, H-RH, H-LH

page 7

7 Screw jack housing fixing holes

FF, FP

page 72

8 Screw jack stroke length (ex.: C300 = 300 mm stroke)

9 Options

NF, P, TF, N Screw end

page 68 - 71

B Bellows

page 74

SC Trunnion mount

page 73

SN Stop nut

page 72

T Protective tube

page 72

AR Anti-turn device

page 73

FCM-NC Magnetic stroke end switches (normally closed)

page 78

FCP-NC Proximity stroke end switches (PNP, normally closed)

page 79

10 Other options

example: encoder (with all relevant data)

11 Further specifications

example: stainless steel acme screw AISI 303

example: low temperature lubricant

12 Motor specifications

13 Coding form

page 81

14 Application sketch

Screw jacks SJ Series - coding description

Screw jacks SJ Series with travelling screw (Mod.A)

UPWARD mounting

UPWARD mounting

DOWNWARD mounting

DOWNWARD mounting

Screw jacks SJ Series - coding description

Screw jacks SJ Series with travelling nut (Mod.B)

SJ	50	Mod.B	RL1	Vers. 3 (80 B5)	U-RH	FF	C300
1	2	3	4	5	6	7	8
N	B2	MB+SBC	B1				
9							
...							
10							
...							
11							
AC 3-phase brake motor 0.75 kW 4 poles 230/400 V 50 Hz IP 55 Isol. F							
12							

1	SJ (screw jack SJ Series)	
2	Screw jack size	
5 ... 1000		page 56 - 57, 62 - 63
3	Mod.B (Model: travelling nut)	
4	Ratio and number of acme screw starts	page 56 - 57, 62 - 63
5	Input versions	
Vers.1, Vers.2, Vers.3, Vers.4, Vers.5, Vers.6		page 7
6	Screw jack mounting and input shaft position	
U-RH, U-LH, D-RH, D-LH, H-RH, H-LH		page 7
7	Screw jack housing fixing holes	
FF, FP		page 72
8	Screw jack stroke length (ex.: C300 = 300 mm stroke)	
9	Options	
N	Screw end	page 68 - 71
B ₁ , B ₂	Bellows	page 75
MB	Working nut	page 68 - 71
SBC	Safety nut	page 76
RMG	Adjustable backlash	page 46
10	Other options	
example: encoder (with all relevant data)		
11	Further specifications	
example: stainless steel acme screw AISI 303		
example: low temperature lubricant		
12	Motor specifications	
13	Coding form	page 83
14	Application sketch	

Screw jacks SJ Series - coding description

Screw jacks SJ Series with travelling nut (Mod.B)

UPWARD mounting

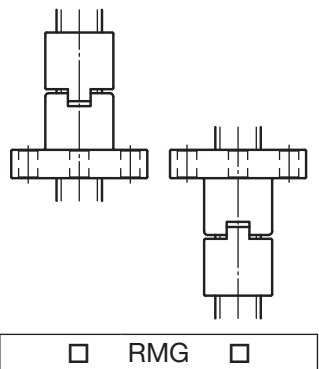

RMG

MB+SBC MB MB+SBC

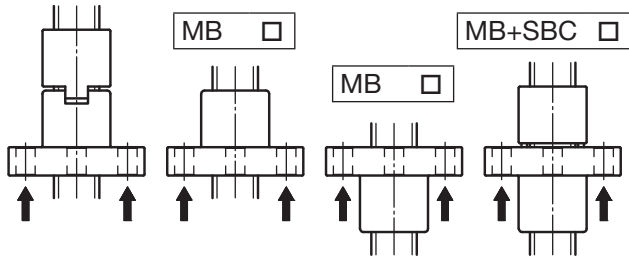

PULL LOAD

PUSH LOAD

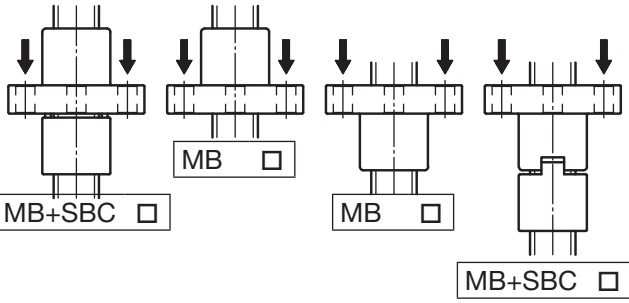

N

B2

B1

FF FP

Version _____

UPWARD mounting

DOWNWARD mounting

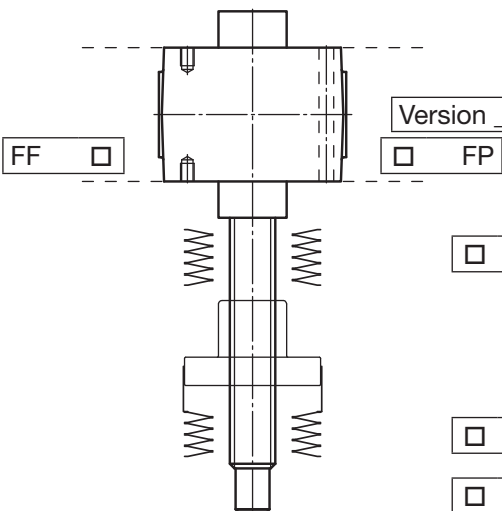

FF Version _____ FP

B1

B2

N

MB+SBC MB MB+SBC

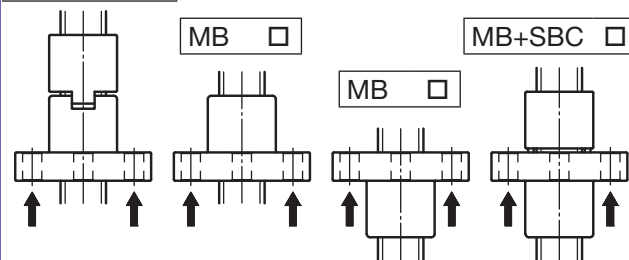

PUSH LOAD

PULL LOAD

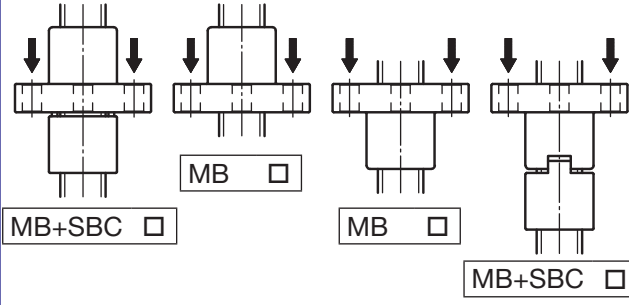

MB+SBC MB MB+SBC

RMG

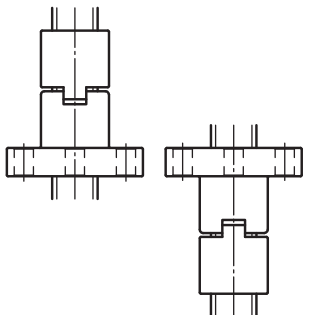

DOWNWARD mounting

3

Screw jacks SJ Series

Screw jacks SJ Series with travelling screw (Mod. A) - spare parts

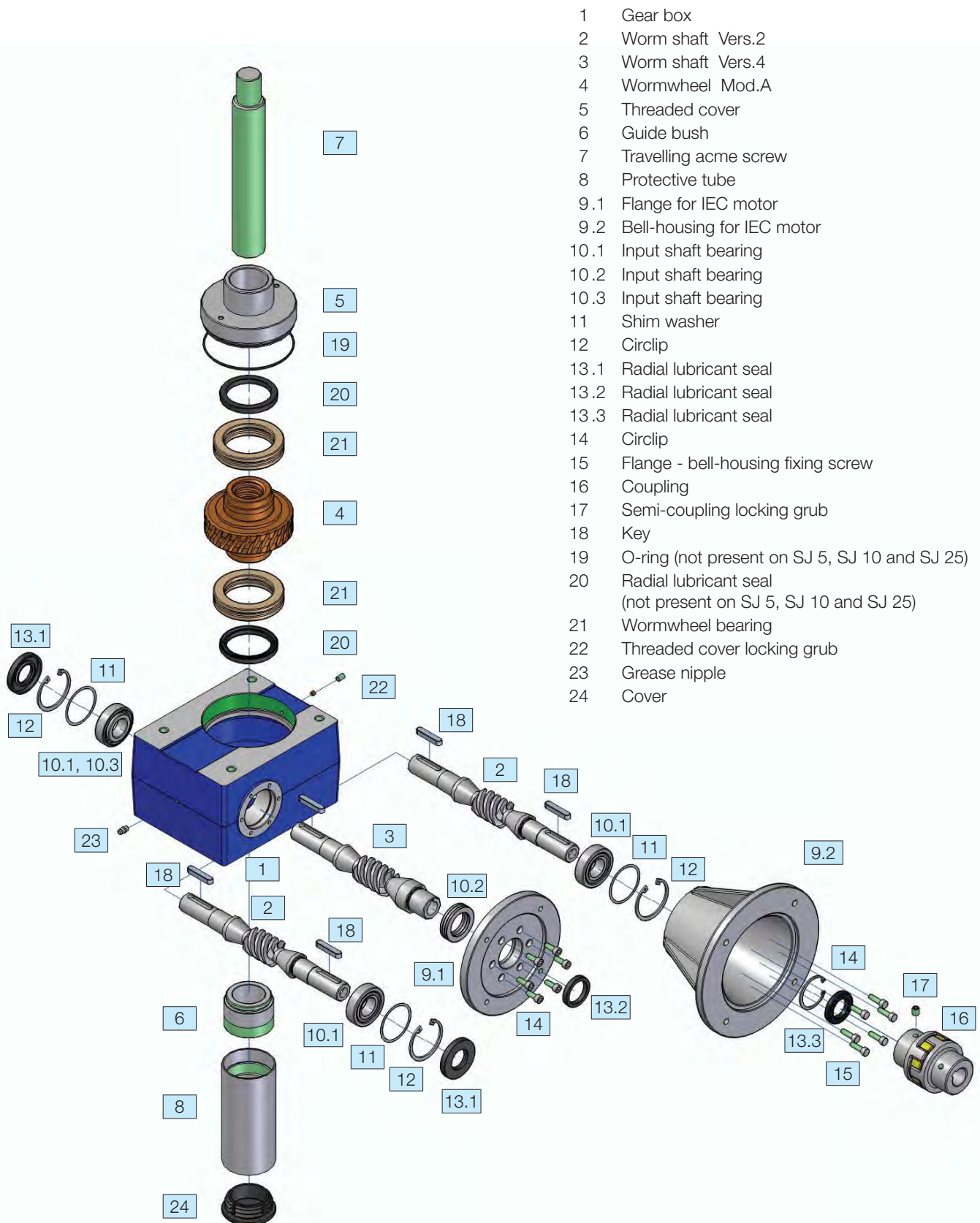

- 1 Gear box
- 2 Worm shaft Vers.2
- 3 Worm shaft Vers.4
- 4 Wormwheel Mod.A
- 5 Threaded cover
- 6 Guide bush
- 7 Travelling acme screw
- 8 Protective tube
- 9.1 Flange for IEC motor
- 9.2 Bell-housing for IEC motor
- 10.1 Input shaft bearing
- 10.2 Input shaft bearing
- 10.3 Input shaft bearing
- 11 Shim washer
- 12 Circlip
- 13.1 Radial lubricant seal
- 13.2 Radial lubricant seal
- 13.3 Radial lubricant seal
- 14 Circlip
- 15 Flange - bell-housing fixing screw
- 16 Coupling
- 17 Semi-coupling locking grub
- 18 Key
- 19 O-ring (not present on SJ 5, SJ 10 and SJ 25)
- 20 Radial lubricant seal (not present on SJ 5, SJ 10 and SJ 25)
- 21 Wormwheel bearing
- 22 Threaded cover locking grub
- 23 Grease nipple
- 24 Cover

For spare parts orders we recommend you to refer to the relative product serial number, marked on the product label fixed on the screw jack housing.

Screw jacks SJ Series

Screw jacks SJ Series with travelling nut (Mod. B) - spare parts

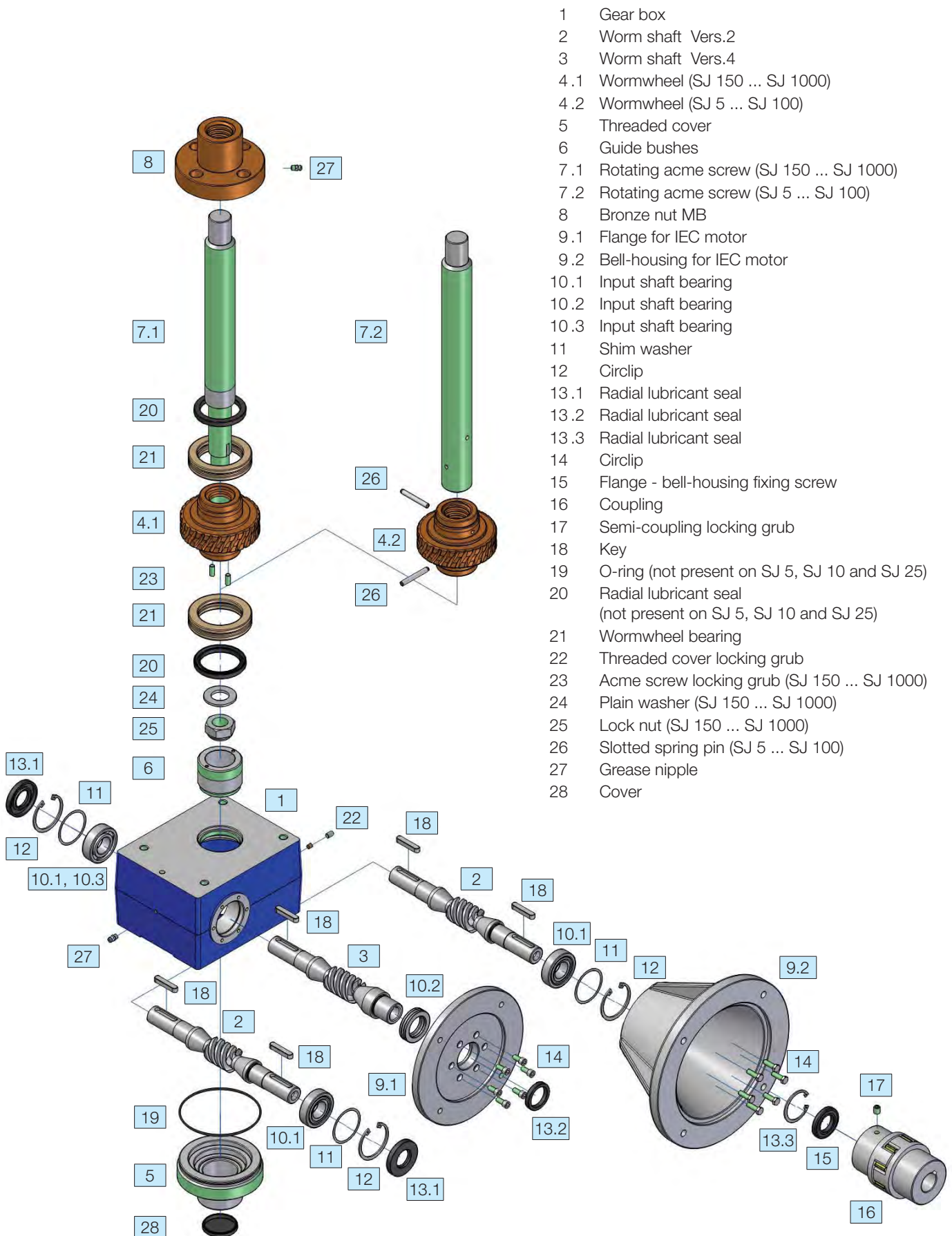

- 1 Gear box
- 2 Worm shaft Vers.2
- 3 Worm shaft Vers.4
- 4.1 Wormwheel (SJ 150 ... SJ 1000)
- 4.2 Wormwheel (SJ 5 ... SJ 100)
- 5 Threaded cover
- 6 Guide bushes
- 7.1 Rotating acme screw (SJ 150 ... SJ 1000)
- 7.2 Rotating acme screw (SJ 5 ... SJ 100)
- 8 Bronze nut MB
- 9.1 Flange for IEC motor
- 9.2 Bell-housing for IEC motor
- 10.1 Input shaft bearing
- 10.2 Input shaft bearing
- 10.3 Input shaft bearing
- 11 Shim washer
- 12 Circlip
- 13.1 Radial lubricant seal
- 13.2 Radial lubricant seal
- 13.3 Radial lubricant seal
- 14 Circlip
- 15 Flange - bell-housing fixing screw
- 16 Coupling
- 17 Semi-coupling locking grub
- 18 Key
- 19 O-ring (not present on SJ 5, SJ 10 and SJ 25)
- 20 Radial lubricant seal (not present on SJ 5, SJ 10 and SJ 25)
- 21 Wormwheel bearing
- 22 Threaded cover locking grub
- 23 Acme screw locking grub (SJ 150 ... SJ 1000)
- 24 Plain washer (SJ 150 ... SJ 1000)
- 25 Lock nut (SJ 150 ... SJ 1000)
- 26 Slotted spring pin (SJ 5 ... SJ 100)
- 27 Grease nipple
- 28 Cover

3

For spare parts orders we recommend you to refer to the relative product serial number, marked on the product label fixed on the screw jack housing.